

**U.S.
INSTALLATION
INSTRUCTIONS,
WARRANTY
AND
MAINTENANCE
GUIDE**



SELKIRK CANADA CORPORATION
P.O. Box 526, Depot 1,
Hamilton, Ontario L8L 7X6
(905) 662-6600, 1-800-263-9308
Fax (905) 662-5352



**INSTALLATION
INSTRUCTIONS
&
MAINTENANCE
GUIDE**

FACTORY BUILT TYPE HT INSULATED CHIMNEY



Listed

**Tested to
UL103**

**A MAJOR CAUSE OF CHIMNEY-RELATED FIRES
IS FAILURE TO MAINTAIN REQUIRED CLEARANCES
(AIR SPACES) TO COMBUSTIBLE MATERIALS.**

**IT IS OF THE UTMOST IMPORTANCE THAT THIS
CHIMNEY BE INSTALLED ONLY IN ACCORDANCE
WITH THESE INSTRUCTIONS.**

**PLEASE READ ALL INSTRUCTIONS BEFORE BEGINNING YOUR INSTALLATION.
FAILURE TO INSTALL THIS SYSTEM IN ACCORDANCE WITH THESE
INSTRUCTIONS WILL VOID THE CONDITIONS OF CERTIFICATION AND THE
MANUFACTURERS WARRANTY .
KEEP THESE INSTRUCTIONS IN A SAFE PLACE FOR FUTURE REFERENCE.**

SELKIRK CANADA CORPORATION
P.O. Box 526, Depot 1,
Hamilton, Ontario L8L 7X6
(905) 662-6600, 1-800-263-9308
Fax (905) 662-5352



TABLE OF CONTENTS

TYPES OF APPLIANCE	4
PRE INSTALLATION GUIDELINES	4
TOOLS	4
FRAMING DETAILS	5
CEILING SUPPORT INSTALLATION	5
ATTIC INSULATION SHIELD INSTALLATION	6
FIRESTOP RADIATION SHIELD INSTALLATION	6
ELBOW INSTALLATION	7
ADJUSTABLE WALL SUPPORT INSTALLATION	7 - 8
ADJUSTABLE INTERMEDIATE WALL SUPPORT	8
CATHEDRAL CEILING SUPPORT INSTALLATION	8 - 9
ROOF SUPPORT INSTALLATION	9
ROOF FLASHING INSTALLATION	10
ROOF GUY INSTALLATION	10
STOVE PIPE INSTALLATION	11
MAINTENANCE AND CLEANING OF CHIMNEY	11
CHART 1 - OFFSET CHIMNEY INSTALLATION	12
CHART 2 - CHIMNEY HEIGHT ABOVE THE ROOF	13
CHART 3 - CONNECTOR PIPE CLEARANCES - CATHEDRAL SUPPORT	14
REPLACEMENT PARTS LIST	15
WARRANTY	16
INSTALLATION RECORD & PRODUCT REGISTRATION	17

TYPES OF APPLIANCES

Your Supervent/SuperPro chimney is intended for venting gas, liquid, or solid fuel fired residential type appliances and building heating appliances or as defined in the NFPA 211, in which the maximum continuous flue gas temperatures do not exceed 1000°F. It has been tested and approved to withstand temperatures of up to 2100°F for three ten minute intervals.

PRE-INSTALLATION GUIDELINES

Your Supervent/SuperPro chimney and connecting stove pipe diameter should be sized in accordance with the appliance manufacturer's recommendations.

Plan the installation of your appliance and chimney in such a way that both your chimney and your stove pipe run is as short and straight as possible. By having too long and or multiple bend installations you can reduce system draft which can affect the operation, and or performance of your appliance and or chimney system. The chimney should be located within the building so as to avoid cutting or altering load bearing members such as joists, rafters, studs, etc. If you require to cut or alter an existing load bearing member, special reframing methods are required which often include doubling of adjacent members. If such a case arises, contact your local Building Code Official regarding local regulations and proper installation methods.

Sections of the Supervent/SuperPro chimney which pass through accessible areas of the building such as through closets, storage areas, occupied spaces or anyplace where the surface of the chimney could be contacted by persons or combustible materials must be enclosed in a chase to avoid personal contact and damage to the chimney. The chase may be fabricated using standard building materials. Drywall mounted on 2" x 4" studs is typically used in this situation. The space between the outer wall of the chimney and the enclosure shall be a least 2 inches.

MAINTAIN A 2" MINIMUM AIR SPACE CLEARANCE BETWEEN INSULATED CHIMNEY SECTIONS AND COMBUSTIBLE MATERIALS.

WARNING: DO NOT PLACE ANY INSULATING MATERIALS OR RUN ANY ELECTRICAL WIRING WITHIN THE REQUIRED AIR CLEARANCE SPACE SURROUNDING THE CHIMNEY.

Before commencing the installation ensure that you obtain any necessary building permits, and that your installation will conform with all federal and municipal building code requirements.

CONTACT LOCAL BUILDING OR FIRE OFFICIALS ABOUT RESTRICTIONS AND INSTALLATION INSPECTION IN YOUR AREA.

The National Fire Protection Association Standard 211 states: Factory-built chimneys that pass through floors of buildings requiring the protection of vertical opening shall be enclosed with approved walls having a fire resistance rating of not less than 1 hour where such chimneys are located in a building less than four stories in heights, and not less than 2 hours where such chimneys are located in a building four or more stories in height.

WEAR SAFETY GLOVES WHEN HANDLING SHEET METAL PARTS WITH SHARP EDGES

Authorities require that the chimney extend not less than 3 feet above the highest point where it passes through the roof of a building and not less than 2 feet above any portion of the building within 10 feet (see figure 1). See Chart 2 for Chimney Height Above the Roof at the back of these instructions.

FIGURE 1

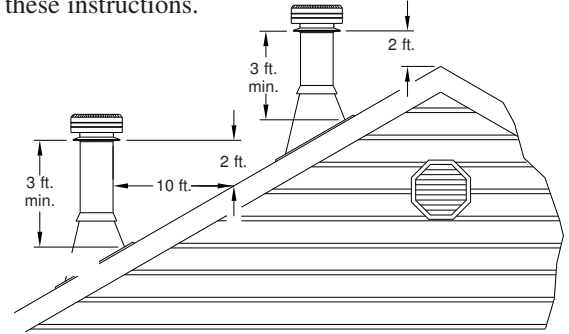

The use of locking bands at all chimney joints is recommended for added safety and stability when exposed to high winds and as a precaution against accidental unlocking of lengths when the system is inspected and swept.

The ideal location for your chimney system is within the building envelope. In cold climates, the use of external chimneys may result in operational problems such as poor draft, excessive condensation of combustion products and rapid accumulation of creosote. Under these circumstances, the installation of the chimney within the building is strongly recommended.

If the chimney must be installed on an exterior wall it is recommended that the chimney be enclosed below the roof line to protect the chimney from cold outdoor temperatures, this may help reduce condensation, creosote formation and enhance draft. Provide an access door by the Tee Plug for chimney inspection and cleaning. The exterior enclosure may be insulated, maintaining the required minimum air space clearance of 2" to any part of the chimney. Consult local building codes for cold climate application.

Do not install the chimney directly at the outlet of the appliance. Interconnecting stove pipe is required unless the appliance is specifically approved for that type of installation.

Use only with an appliance listed by a recognized testing authority such as Underwriters Laboratories Inc., Underwriters Laboratories of Canada or Intertek Testing Services.

The flue diameter of gas or oil fired appliances should comply with the appropriate NFPA or ANSI Installation Codes; NFPA 54, ANSIZ223.1, and NFPA 31.

YOUR CHIMNEY HAS BEEN TESTED, AND LISTED USING ALL OF THE SUPPORTS, SHIELDS, ETC., DESCRIBED HEREIN. DELETION OR MODIFICATION OF ANY OF THE REQUIRED PARTS OR MATERIALS MAY SERIOUSLY IMPAIR THE SAFETY OF YOUR INSTALLATION, AND VOID THE CERTIFICATION AND OR WARRANTY OF THIS CHIMNEY

TOOLS

Your Supervent/SuperPro chimney system is designed for installation using standard building materials and procedures. The following tools/equipment may be required as well as some others depending on the location and structure in which the chimney is to be installed:

- safety gloves
- safety goggles
- hammer and nails
- tin snips
- tape measure
- screwdriver and pliers
- plumb line and level
- square
- keyhole saw or power jig saw
- caulking gun

FRAMING DETAILS:

Plan your installation carefully. If possible, position the stove so that the flue outlet is between joists or rafters. Drop a plumb line to the center of the flue outlet and mark this center point on the ceiling. Lay out and frame in all openings ensuring the specified 2" clearance to combustibles is maintained. Refer to Table 1 for framing dimensions and mark the appropriate cutting lines around the center point. All openings should be square (all four sides), plumb and in perfect alignment with each other. See figure 2.

For sloping roofs, ensure that the framing dimension is measured in the horizontal plane. See figure 3.

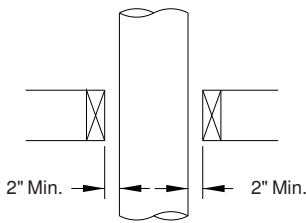

FIGURE 2
Typical Joist Framing

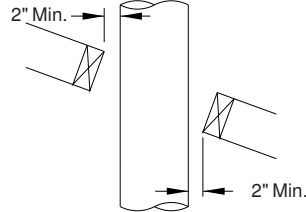

FIGURE 3
Typical Roof Joist Framing

Chimney Flue Diameter	Framing Dimensions		
	*Decorator Ceiling Support	* Wall (Support) Thimble	All Other Framing
5"	12 ³ / ₈ x 12 ³ / ₈	14 ³ / ₈ x 14 ³ / ₈	11 x 11
6"	12 ³ / ₈ x 12 ³ / ₈	14 ³ / ₈ x 14 ³ / ₈	12 x 12
7"	13 ³ / ₈ x 13 ³ / ₈	14 ³ / ₈ x 14 ³ / ₈	13 x 13
8"	14 ³ / ₈ x 14 ³ / ₈	14 ³ / ₈ x 14 ³ / ₈	14 x 14

Note: *When cutting the inside "finished" surface of your wall or ceiling cut a "round hole" to the framing dimension.

TABLE 1

INSTALLATION PROCEDURES:

CEILING SUPPORT

To complete a proper Decorator Ceiling Support installation, the following parts will or may be required:

- Decorator Ceiling Support:
- Attic Insulation Shield: - Required where a chimney passes into an unoccupied attic space.
- Firestop Radiation Shield: - Required where a chimney passes from a lower living space into an upper living space or occupied attic space
- Roof Flashing Assembly: - Required where the chimney penetrates a roof.
- Rafter Radiation Shield: - Required when the chimney is enclosed immediately below the roof.
- Suitable lengths of Chimney: - The chimney diameter should be sized to suit the appliance.
- 15° or 30° Chimney Elbow : - and suitable supports (roof support or elbow support), if required.
- Rain Cap: - Standard or Deluxe model

The Supervent/SuperPro Ceiling Support will support up to 50 feet of chimney sections, all of which must be installed above the support. Figures 4 & 5 show the 2 most common types of Ceiling Support Installation. Frame (on all 4 sides) a level square opening to the dimensions specified in the Framing Dimension Table 1.

Slide the Trim Ring onto the Ceiling Support and slide the assembly into the framed opening from below. Ensure that the finishing plate is flush with the underside of the ceiling and the assembly is level and plumb. Secure the ceiling support in place using at least three (3) 8-penny (2-1/2") nails through each of the 4 straps or through the 12 pre-punched holes in the support. You may substitute in lieu of nails 12 - #8 x 2" wood screws.

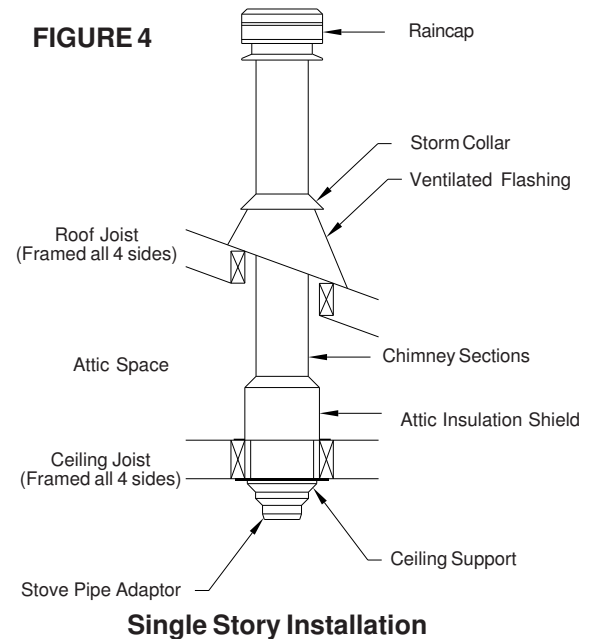

STOVE PIPE ADAPTOR

The Stove Pipe Adaptor (ASE) is installed from below the Decorator Ceiling Support as per the diagram below. Lower the first section of chimney into the Decorator Ceiling Support ensuring that the male coupler is pointing upwards as indicated by the arrow on the chimney label. Center this first chimney section in the Decorator Ceiling Support and from beneath the support insert the Stove Pipe Adaptor and lock it into place by turning clockwise until tight. This will hold your chimney section in place while the rest of the installation is completed.

The crimped end (stub) of the Stove Pipe Adaptor is intended to fit inside of the flue pipe from a solid fuel appliance, thus preventing condensate drips at the chimney connection. Install inter-connecting

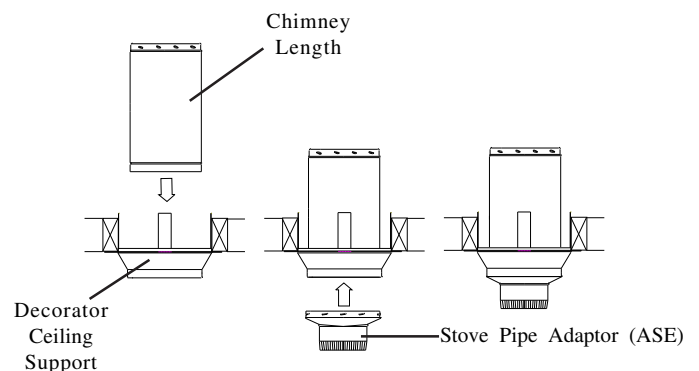

flue pipe following the appliance manufacturer's installation instructions and appropriate building code requirements keeping in mind that the flue pipe run should be as short and straight as practicable. Generally, for a wood burning appliance installation, an 18" minimum clearance to combustibles must be maintained for a single wall fue pipe. The exception to this is a double wall stove pipe, such as Selkirk's **Model DSP** which can be installed at reduced clearances to combustibles. See separate installation instructions for more details.

Install additional chimney sections and lock together by turning clockwise until the two sections lock together tightly. Install a locking band to secure the two chimney sections. Continue adding chimney lengths until a height of about 2ft. below the next ceiling level is achieved.

ATTIC INSULATION SHIELD

An Attic Insulation Shield (AIS) must be installed where the chimney enters an attic space. An Attic Insulation Shield is to keep insulation from coming into contact with the chimney and will allow a depth of insulation of 10 inches plus the depth of the ceiling joist. Where height restrictions will not permit the use of the Attic Insulation Shield, an enclosure from the attic joist to the roof joist will be sufficient. All chimney enclosures must maintain the required minimum air space clearance of 2" to the chimney. When enclosing the chimney below the roof line, a Rafter Radiation Shield (RRS) must be installed at the roof level and a Firestop Radiation Shield (RRS) at the ceiling level.

For proper installation, the attic opening must be fully framed at 2 inches of clearance to the chimney pipe with framing material of the same dimension as the ceiling joists (as per Framing Dimension Table 2). The tabs on the plate of the AIS are inserted in the framed opening around the chimney. Nail the AIS base to the framing dimensions with at least 2 per side using 2d (1") spiral nails or 1" x #8 wood screws.

When an Attic Insulation Shield is required above the Ceiling Support into an attic as shown in Figure 4, ensure that the base of the shield is flush with the top of the joist framing and nailed in place. The telescoping portion of the AIS will eliminate the need to trim the bottom when installed immediately above the ceiling support. When fully extended, the AIS will provide joist shielding when installed in a 2 story main floor application (see Fig.5).

If insulation is blown in and adheres to the chimney pipe, it must be brushed off to eliminate any possible contact of this material with the chimney surface.

FIRESTOP RADIATION SHIELD

A Firestop Radiation Shield must be installed where the chimney passes from one living space to another living space, as shown in figure 6. It is designed to provide proper firestopping between floors and to keep direct radiation from the chimney away from the joist framing.

Chimney Flue Diameter	Framing Dimensions for Attic Insulation Shield	
	Inches	mm
5"	11 x 11	280 x 280
6"	12 x 12	305 x 305
7"	13 x 13	330 x 330
8"	14 x 14	356 x 356

TABLE 2

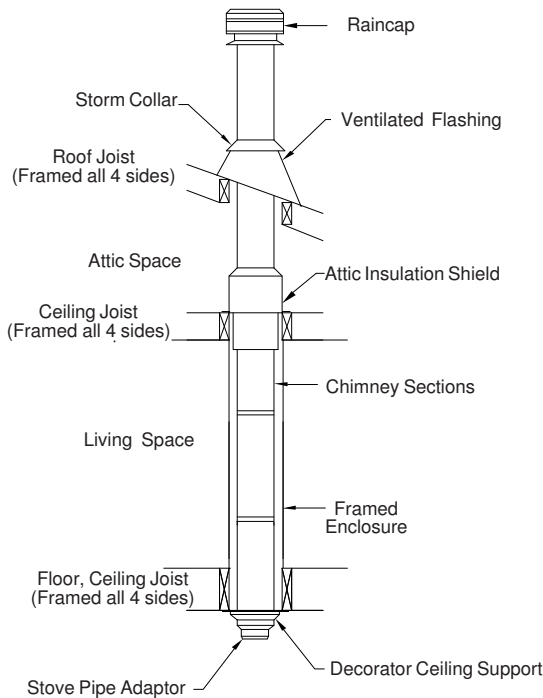

FIGURE 5
Two Story
Main Floor Installation

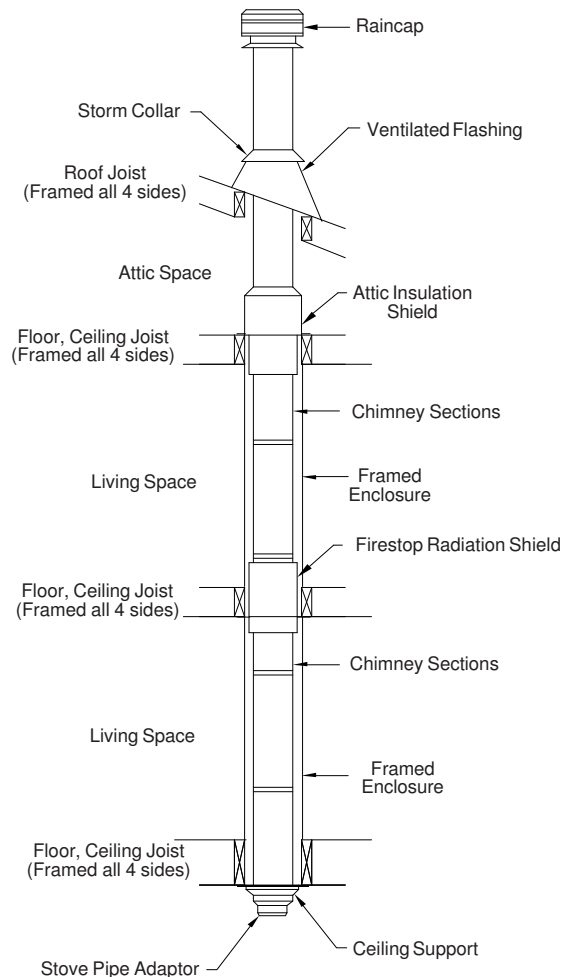

FIGURE 6
Two Story
Basement Installation

Install the Firestop Radiation Shield (FRS) from below the joist framing and nail in place using 1" spiral nails. Ensure no insulation is within the 2" air space clearance around the chimney. This includes the air spaces between the Firestop Radiation Shield (FRS) and the joist framing.

When the chimney is enclosed in the attic area, a Firestop Radiation Shield (FRS) must be installed at the ceiling level. If the base of the Firestop Radiation Shield (FRS) does not fit flush with the ceiling frame, measure the distance that the base is sitting below the framing and trim that amount off of the top of the FRS before securing into place.

ELBOW INSTALLATION

One pair of (two) 15° or 30° elbows may be used in an interior installation to provide an offset in order to avoid cutting of joists and to clear other obstructions. Each elbow support will support 10 feet of chimney and the Maximum length of chimney allowed between the elbows is 6 feet. See Chart 1 in these instructions for more details.

The female end of the elbows are **not** embossed, in order to ensure proper alignment of the chimney system can be maintained. Locking bands must be installed at all chimney joints forming an offset.

Install the insulated offset elbow on the vertical chimney length and position the elbow in the required direction. Fasten the elbow to the chimney length with the supplied Locking Band.

Place the required offset chimney length(s) as per the Offset Chart for appropriate length(s). Turn it clockwise to lock it in place and fasten in place with the supplied Locking Band.

Install the remaining offset elbow to turn the chimney back to the vertical position and fasten in place with the supplied Locking Band.

During installation provide supplementary support for the offset section to avoid undue stress on connected elbows.

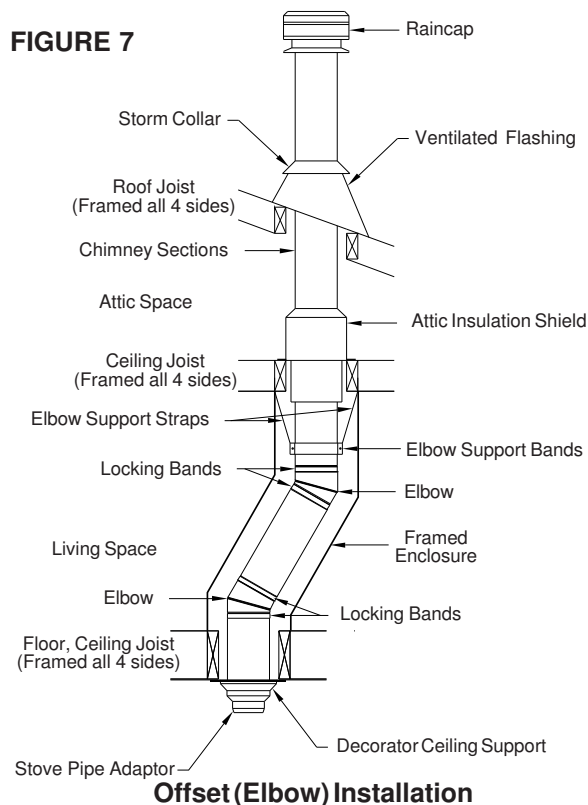

Install an elbow support just above the highest elbow. Attach the Support Band to the chimney with 4 of the nuts and bolts, and then install the four stainless steel sheet metal screws through the pre-punched holes. Attach the Support Straps to the Support Band assembly and nail the Support Straps to the framing using 6d (2") nails or #8 x 1-1/2" wood screws (see figure 7).

Never install an elbow in a joist area. Chimney sections must pass vertically through framed joist areas.

WALL SUPPORT

To complete a proper Wall Support installation, the following parts will or may be required:

- Adjustable Wall Support:
- Roof Flashing Assembly: - Required when the chimney penetrates a roof or a roof overhang.
- Rafter Radiation Shield: - Required when the chimney is enclosed immediately below the roof.
- Wall Bands: - Required to provide lateral support to chimney.
- Suitable lengths of chimney: - The chimney diameter should be sized to suit the appliance.
- Wall Thimble: - Required to pass through a combustible wall.
- Rain Cap: - Standard or Deluxe model

NOTE: NEVER OFFSET AN EXTERIOR CHIMNEY.

The Supervent/SuperPro Adjustable Wall Support will support up to 30 feet of chimney, all of which must be above the support with the exception of the 1 foot cleanout section and/or the Insulated Tee Plug, which is installed below the support.

If the total chimney height exceeds the adjustable wall support limitations, an Adjustable Intermediate Wall Support must be installed. The use of an AIWS will support up to 30 feet of chimney.

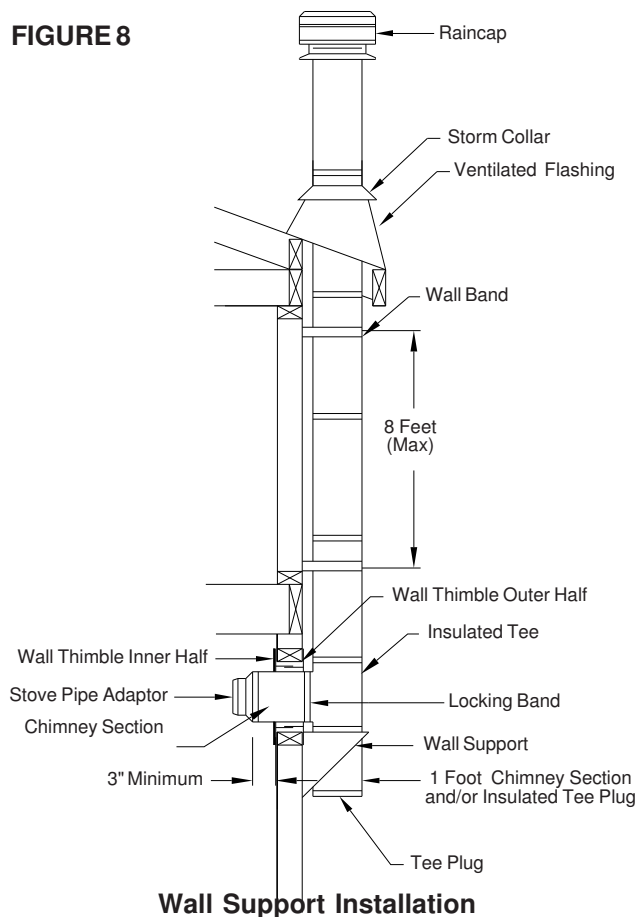

If the total chimney height exceeds the adjustable wall support limitations, an Adjustable Intermediate Wall Support must be installed. The use of an AIWS will support up to 30 feet of chimney.

After framing in your opening to the dimensions specified in the Framing Details section, install the outer half (with square plate) of the wall thimble in the outside wall surface. Secure in place using appropriate fasteners using all of the pre-punched holes. For a non combustible wall, cut a hole 3/16" greater than the outside diameter of the chimney.

Install the inner half (with round plate) of the wall thimble in the inside wall surface, ensuring that the shield slides into the shield of the outer half. Once in place and flush against the wall, install the trim plate and fasten in place with appropriate fasteners through the four pre-punched holes.

Assemble the Wall Support (Figure 9) by attaching the 2 side brackets to the support plate, with the hardware supplied. Ensure that the female coupler attached to the underside of the support plate is facing down. For an adjustment of the support plate, align the fixed holes on the support plate with the elongated holes on the side brackets.

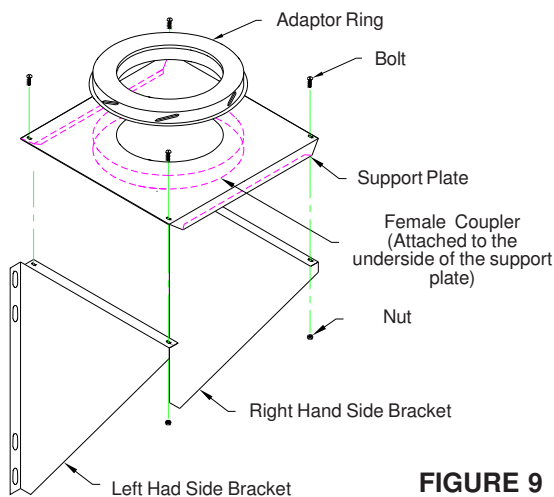

FIGURE 9

Install a one foot (or longer as required) length of insulated chimney to the horizontal branch of the insulated tee. Lock securely into the tee by twisting clockwise. A locking band must then be installed at this connection. Make sure the nut and bolt are facing down to prevent any water from collecting in the locking band. The Tee branch must penetrate a minimum of 3" into the room.

NOTE: Ensure that you have set aside the Tee Plug, if not, do so now as you will require it later.

From outside the building, slide the chimney length (previously installed on a tee) through the wall thimble ensuring the male coupling on the tee is facing upward. Place the adaptor ring (Figure 9) on the wall support so that the sleeve on the adaptor drops through the hole in the support plate. Place the assembled wall support against the wall (plate up) directly below the tee. Slide the wall support up to the tee ensuring that the adaptor on the wall support engages with the female coupler of the tee (bottom of tee).

Ensure the wall support is level, and secure to the wall with four 1/4" by 2" Lag Bolts through the pre-punched slots in each bracket. If the support is properly positioned, these lag bolts will go into wall studs placed on 16" centers. For concrete walls use suitable fasteners.

NOTE: THE CHIMNEY MUST EXTEND AT LEAST 3" (75 MM) INTO THE LIVING SPACE WHERE THE STOVE PIPE CONNECTOR WILL BE ATTACHED TO THE CHIMNEY BRANCH.

Use a non-hardening high-temperature silicone caulking to seal around the horizontal chimney length where it enters on the exterior of the Wall Thimble or the concrete wall.

Twist lock a 12" section into the Female Coupler beneath the Support Plate. Twist lock the Tee Plug into the bottom of the section. You can substitute an Insulated Tee Plug (ITP) for the 12" section.

Install a Wall Band midway up the first chimney length above the Insulated Tee. Wall Bands must then be installed at 8 foot intervals above this point (see figure 8). Secure the Wall Band bracket to the wall using two 6d (2") spiral nails or #8 x 2" wood screws or longer if need be. For concrete walls use suitable masonry fasteners. The nut and bolt supplied will fasten the band around the chimney.

If the chimney penetrates an overhang (soffit) cut an opening with 2" clearance all around and install an Attic Insulation shield if space permits on the under side of the overhang. If it is not possible the overhang area can be enclosed and a Rafter Radiation shield installed at the roof level. If the attic is open to the overhang, close off the access with suitable building materials ensuring that a 2" air space is maintained. From above, install the Roof Flashing and Storm Collar by following the Roof Flashing section in these instructions. If the overhang is not deep enough to allow the chimney to be fully installed within the overhang, it will be necessary to cut into it. **DO NOT INSTALL OFFSET TO CLEAR THE OVERHANG!** Ensure that a 2" clearance all around the chimney is respected. Framing and flashing the sides of the opening will be required. Install a Wall Band at this level.

ADJUSTABLE INTERMEDIATE WALL SUPPORT

If the total chimney height exceeds the wall support limitations an Adjustable Intermediate Wall Support must be installed. Use of an AIWS will support another 30ft. of chimney. Slide the assembled intermediate wall support over the protruding length of chimney. Fasten the intermediate wall support to the wall using four 1/4" by 2" wood screws through the pre-punched slots in each bracket. Install the draw band around the protruding chimney length securely against the support plate. Install four stainless steel sheet metal screws firmly into the outer casing of the chimney, through the pre-punched holes in the draw band. Cover the heads of the screws with a non-hardening waterproof caulking.

CATHEDRAL CEILING SUPPORT

To complete a proper Cathedral Ceiling Support installation, the following parts are required:

- Cathedral Ceiling Support:
- Roof Flashing Assembly: - Required when the chimney penetrates a roof.
- Suitable lengths of chimney: - The chimney diameter should be sized to suit the appliance.
- Rain Cap: - Standard or Deluxe model

The Supervent/SuperPro Cathedral Ceiling Support will support a total of 30 feet, of chimney. Chimney joints made below the support must be secured with locking bands.

After framing in your opening to the dimensions specified in the Framing Details section, slide the Cathedral Support box into joist opening. Once the box is at the desired level, ensure the box is level and nail the box to the framing using four 2" spiral nails or #8 x 1-1/2" wood

screws per side. The excess material sticking above the roof can either be trimmed off before attaching the box to the framing or, after it is installed the corners can be cut and the excess material folded down onto the roof deck.

Install the Support Band on the chimney length at the desired position by tightening the draw band bolt and by screwing four stainless steel sheet metal screws through the draw band and into the outer casing. Lower the chimney length down through the opening in the bottom of the support so that the Support Band makes contact with the bottom of the Support Box. (See Figure 10).

NOTE: The male coupler of each chimney length must be up.

The bottom chimney length(s) must protrude into the living space so that proper clearances are maintained from the stove pipe connector to the lower side of the ceiling. Refer to Chart 3 at the back of these instructions for proper clearance.

Install additional chimney sections and lock together by turning clockwise until the two sections lock together tightly. Continue in this manner until the required height above the roof is achieved. Chimney sections (15 feet max.) installed below the Cathedral Ceiling Support are locked together from below by turning clockwise until tightly locked together with each joint being secured by a locking band.

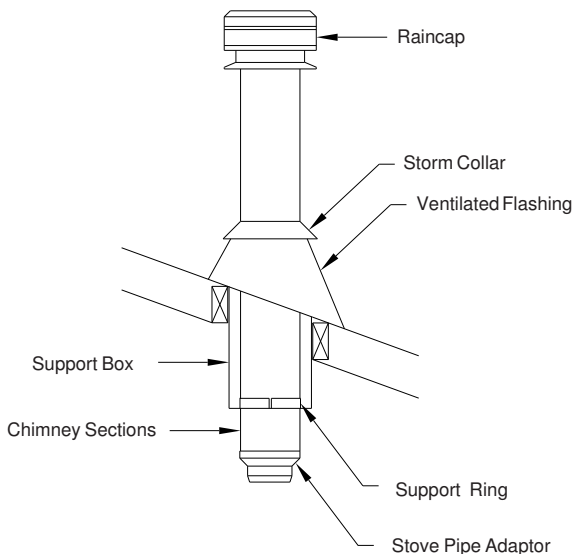

FIGURE 10 Cathedral Ceiling Support Installation

ROOF SUPPORT

The Roof Support may be used on a floor, ceiling or roof and adjusts to any roof pitch. It may be used above an offset to support the offset or as a supplementary support when the chimney height exceeds that of the primary support.

The Roof Support will support a total height of 50 feet of chimney sections. All chimney sections below the support must be secured with locking bands.

Attach the support brackets to the support band with the 1/2" nuts, bolts and lock washers. The lock washer is placed between the band and support bracket to provide proper spacing as shown in Figure 11.

FIGURE 11

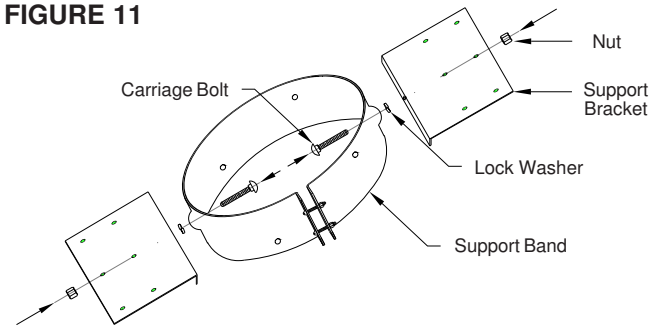

Roof Support Assembly

Slide the Roof Support down over the chimney section until its brackets rest on the roof or floor. Tighten the collar around the chimney with the nuts and bolts supplied, then secure the collar by screwing the 6 supplied sheet metal screws through the holes in the collar and into the chimney.

Center the chimney in the joist and nail or screw the support to the roof or floor using the 12 - 3 1/2" spiral nails supplied or 12 #8 - 1 1/4" wood screws.

Install additional chimney sections and lock together by turning clockwise until the two sections lock together tightly - continue in this manner until the desired height is achieved.

NOTE: The male coupler of each chimney length must be up.

RAFTER RADIATION SHIELD:

A Rafter Radiation Shield must be installed where the chimney is enclosed immediately below the roof line as shown in figure 15. An example of this is when the attic space of a house is being used as living space (ie. bedroom, guestroom etc.). It must also be installed when height restrictions will not allow the use of the Attic Insulation Shield (AIS) and the chimney has been enclosed with an enclosure around the chimney.

Attach the support brackets to the shield (through one of the three pre-punched holes) such that once the shield is installed, the shield protects both the upper and lower parts of the roof joist framing (See figures 12 & 15).

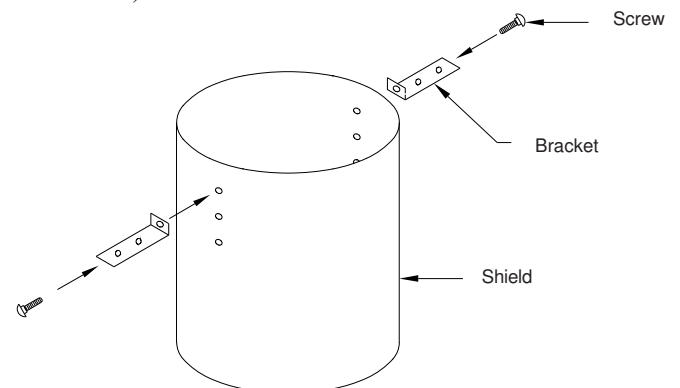

FIGURE 12

Rafter Radiation Shield Assembly

ROOF FLASHING:

Ensure that you have the proper roof flashing by checking your roof pitch using a level and two rulers (see fig. 13) or by using a roof pitch card.

The AAF flashing is for roof pitches from 0/12 to 6/12.

The AF2 flashing is for roof pitches from 6/12 to 12/12.

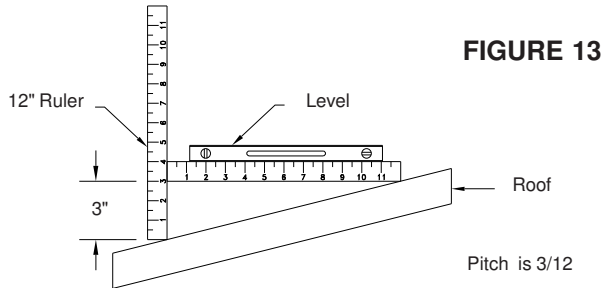

Roof Pitch Calculation

Once you have marked and located the area where the chimney will come through the roof, center, position and prepare the roof area by removing shingles, shingle nails and cutting roofing material allowing for a 2" clearance to the chimney on all four (4) sides. This is done before extending the chimney above the roof. Do not nail the flashing to the roof yet as adjustments may be required.

NOTE: Slide the top edge (nearest the roof peak) of the flashing under the roof shingles. At least half of the flashing should be UNDER the shingles and the end OVER the shingles to provide a watershed. Trimming off the shingles may be necessary around the cone of the flashing for a better fit. On existing roof application, lower a chimney length into the flashing opening and twist lock in place. Ensure that the chimney is level and plumb before nailing the flashing to the roof.

Nail the flashing to the roof deck (also under the shingles) along the upper edge and down each side with 12 nails with neoprene washers or cover the nails with a suitable non hardening waterproof caulking. Seal the shingles to the plate in the same manner. As a precaution, you may apply a bead of caulking along all seams of the flashing.

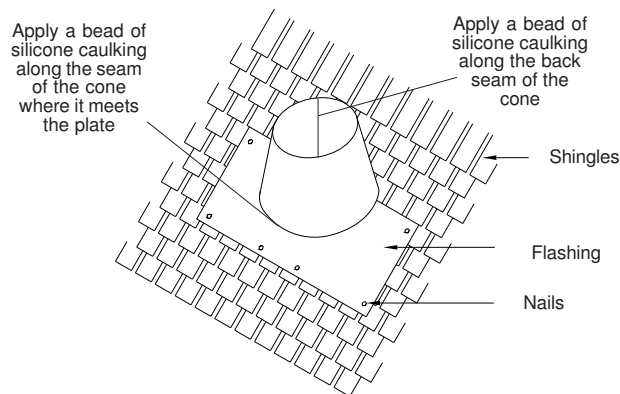

FIGURE 14 Roof Flashing Installation

Wrap the Storm Collar around the chimney above the flashing. Secure the ends together loosely with the nut and bolt supplied.

Apply a non-hardening high temperature silicone caulking just above the top of the flashing cone on the chimney casing. Slide the collar down the chimney until it contacts the flashing and the caulking. Tighten the nut and bolt and apply additional caulking above the storm collar as required. After the installation check to ensure that the ventilation slots are not obstructed. (See Figure 15).

On metal or steep roofs, it is recommended that a chimney cricket fabricated from heavy sheet metal be installed. This will protect the chimney and the flashing by routing the snow load and ice around the chimney. This is not a supplied item. Contact a sheet metal fabrication shop in your area for your custom chimney cricket.

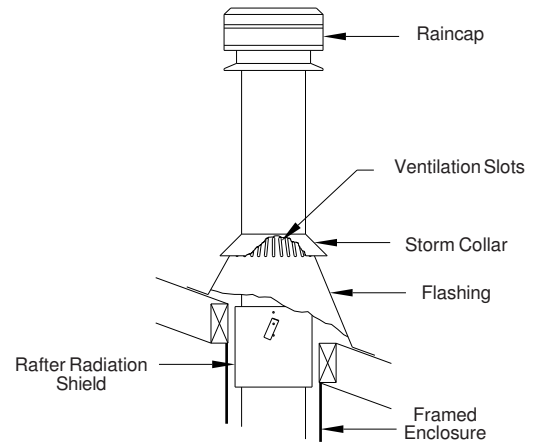

FIGURE 15 Storm Collar/Flashing Installation

WARNING: DO NOT BLOCK THE VENTILATION SLOTS ON THE FLASHING.

The flashing and storm collar should be painted to match the roof shingles. This will extend its life and improve the appearance. The chimney may be painted also with a HEAT RESISTANT paint. To improve adhesion to the Supervent/SuperPro chimney, degrease, clean, prime before painting. Follow the paint manufacturer's instructions.

Continue adding chimney lengths until the proper height is achieved (See figure 1). Install locking bands at all chimney joints above the roof for added protection. Install the rain cap and lock it in place by turning clockwise until tight.

ROOF GUY INSTALLATION

If the chimney extends 5 feet or more above the roof deck, roof guys are required. The Roof Guy kit containing telescopic legs and draw band are suitable for this application. The draw band must be clamped around the chimney and the two legs lagged to the roof into the rafters and not just the roof sheathing. Position the band approximately two thirds of the way up the chimney height. The preferred location for the band is next to a joint, immediately above or below a locking band.

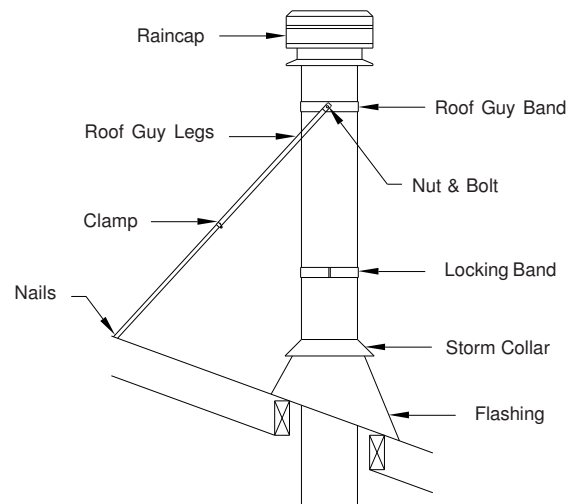

FIGURE 16 Roof Guy Installation

The two telescopic legs should form an angle of about 60 degrees to give support to the chimney in all directions. Keep bottom ends equal distance from the chimney and if possible, at the same elevation, on the high side of the sloped roof. Seal the roof with a suitable non-hardening waterproof caulking. After the legs are attached to the chimney and bands tighten the clamps on the legs to fix the position of the telescoping legs. (See Figure 16).

MAINTENANCE AND CLEANING OF CHIMNEY:

“Creosote and Soot - Formation and Need for Removal”

The need for chimney maintenance depends on the kind of appliance and how it is operated. Gas and oil-burning appliances need very little, but wood-burning appliances may need a great deal of chimney maintenance.

How you burn wood in your stove or fireplace directly affects the formation of creosote. Smaller, hotter fires are better than large, smoldering ones. Fast, effective start-ups are important, as is the moisture content of the wood being burned. Ideally, you should use seasoned wood with a moisture content of 15 to 20%. If your wood is not completely seasoned, use more dry kindling and paper first to warm up the chimney system to a temperature between 350 to 500 degrees F. A good investment in assisting you in monitoring your system is a surface thermometer for single wall stove pipe or a probe thermometer for double wall stove pipe is an excellent tool to assist you in monitoring your system.

When wood is burned slowly, it produces tar and other organic vapors, which combine with expelled moisture to form creosote. The creosote vapors condense in the relatively cool chimney flue of a slow-burning fire. As a result, creosote residue accumulates on the flue lining. When ignited, this creosote makes an extremely hot fire.

With a new installation, the chimney should be inspected frequently (every 2 wks) to determine the rate of creosote formation. When familiar with the appliance and chimney characteristics, the chimney should be inspected at least once every 2 months during the heating season to determine if a creosote or soot build-up has occurred. Check spark arrestor screens at least every 2 to 4 weeks.

If creosote or soot has accumulated, it should be removed to reduce the risk of chimney fire. Depending on the rate of build-up (as little as 1/8") and as you learn what is going on in the chimney, you can adjust your cleaning schedule accordingly.

Contact a local certified chimney sweep for chimney cleaning services and advice if you have any doubts about your ability to clean your chimney system.

The rain cap may be unscrewed using the twist-lock feature. Care should be taken not to disengage any lower chimney sections. This will permit the insertion of a properly sized plastic chimney cleaning brush. The Tee Plug can be removed by turning counter clockwise. Be sure to replace the Tee Plug and the Rain Cap when you are finished cleaning the chimney.

To reduce corrosion in the chimney where coal is burned, clean the chimney thoroughly within 48 hours of shutting down the stove for the season. Ensure that only low sulphur content coal such as anthracite is burned. It is of the utmost importance that all soot be removed.

If chemical cleaner is used to assist in cleaning your chimney make sure it is non corrosive to the chimney liner. The optimal method for cleaning a chimney is by a mechanical brushing of the chimney in conjunction with a complete evaluation of the system by a certified chimney sweep. The National Building Code and the National Fire Protection Association recommend annual inspections.

CHIMNEY FIRES AND WHAT TO DO ABOUT THEM

Your Supervent/SuperPro is not intended or designed for use as a combustion or fire chamber. It is very easy to overfire your woodburning appliance with kindling, scrap lumber, brush or any fast burning fuel. This can produce flames and high temperatures all the way up the chimney, and may cause chimney damage.

If you see your appliance or the stove pipe glowing red, you are risking chimney damage, or a fire. The creosote may be burning inside the chimney. If you see flames coming out the top, you are either overfiring or there is a chimney fire.

If the fire in your appliance has gotten out of control, or if you suspect a chimney fire for any reason, follow these steps:

1. Immediately close all dampers and/or air entrance openings to your appliance. This includes doors on Franklin type stoves. Block off fireplace openings.
2. Alert your family to the possible danger.
3. Inspect your appliance and chimney surroundings for possible fire. If in doubt, alert your Fire Department.
4. Do not continue to use your appliance until it and your chimney have been thoroughly inspected. Overheating can cause metal parts to expand, buckle and crack. If you are not certain, have a certified wood technician or certified chimney sweep disassemble all parts so they can be inspected and replaced.
5. Do not use salt or water on the fire in your appliance. Salt is corrosive and water will cause a dangerous steam explosion. You might be able to control the fire by using ashes, sand or baking soda, since baking soda is an ingredient used for dry chemical fire extinguishers.
6. After a chimney fire, when it is safe to do so, check internal locations such as the attic and under the roof and keep watching for two or three hours. There may be delayed smoldering and subsequent ignition, even if the fire inside the chimney has been controlled.

**WARNING:
DO NOT USE FUEL MATERIALS CORROSIVE TO
THE CHIMNEY LINERS SUCH AS DRIFTWOOD,
PLASTICS, CHEMICALLY TREATED WOOD, ETC.**

CHART 1 - OFFSET CHIMNEY INSTALLATION

When the chimney path cannot be perfectly straight, the need to install a chimney offset must be used when it becomes necessary to offset the chimney in order to clear a joist or an obstacle. The two (2) charts below will assist you in selecting the proper combination of elbow angle and chimney length(s) that will provide the necessary degree of offset within an available height.

1. Select the column with the proper chimney diameter of your system.

2. Determine the distance of the offset required by dropping a plumb line for an accurate measurement. The offset is measured at the chimney centre line as per the "A" Offset measurement in the diagram below.

3. On the chart, find the predetermined distance (under the "A" column) required for the 15° elbow. For greater offset, use the 30° offset chart.

4. After finding the offset, look at the "B" (Height) measurement in the diagram below and under column "B" in the chart to find the specified height. The appropriate "chimney lengths" required in between elbows is found in the left hand side column on the chart.

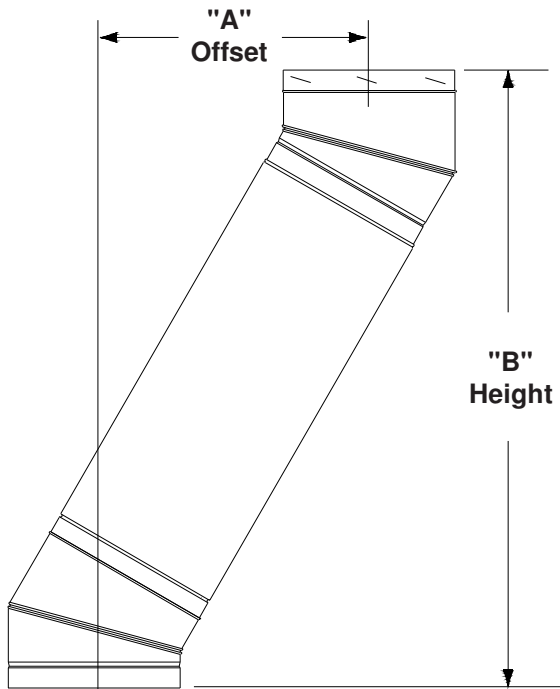

Chimney Lengths	6" Diameter		7" Diameter		8" Diameter	
	A	B	A	B	A	B
none	1-1/8"	10"	1-1/8"	10-1/4"	1-1/4"	10-3/8"
6"	2-3/8"	14-1/4"	2-3/8"	15"	2-1/2"	15-5/8"
12"	4"	20-1/2"	4-1/16"	20-3/4"	4-1/8"	21"
18"	5-1/2"	26-1/4"	5-1/2"	26-1/2"	5-5/8"	26-3/4"
24"	7"	32"	7-1/16"	32-1/4"	7-1/8"	32-1/2"
6" + 24"	8-3/8"	36-3/4"	8-3/8"	37"	8-3/8"	37-1/4"
36"	10-1/4"	43-5/8"	10-1/4"	44"	10-1/4"	44-1/8"
6" + 36"	11-3/8"	48-3/8"	11-1/2"	48-5/8"	11-1/2"	48-7/8"
12" + 36"	13"	54-1/8"	13"	54-3/8"	13"	54-5/8"
18" + 36"	14-1/2"	60"	14-1/2"	60-1/8"	14-5/8"	60-3/8"
24" + 36"	16-1/8"	65-3/4"	16-1/8"	66"	16-1/8"	66-1/4"
12"+24"+36"	19"	76-1/4"	19"	76-1/2"	19"	76-3/4"

Chimney Lengths	6" Diameter		7" Diameter		8" Diameter	
	A	B	A	B	A	B
none	2-3/4"	11-5/8"	3-1/8"	13"	3-1/2"	14-1/2"
6"	5-1/4"	15-7/8"	5-5/8"	17-1/4"	6"	18-3/8"
12"	8-1/4"	21"	8-5/8"	22-3/8"	9"	24"
18"	11-1/4"	26-1/4"	11-5/8"	27-5/8"	12"	29-1/8"
24"	14-1/4"	31-3/8"	14-5/8"	32-7/8"	15"	32-3/8"
6" + 24"	16-5/8"	35-5/8"	17"	37"	17-1/8"	38-1/2"
36"	20-1/4"	41-7/8"	20-5/8"	43-1/4"	21"	44-3/4"
6" + 36"	22-5/8"	46"	23"	47-1/2"	23-1/2"	49"
12" + 36"	22-5/8"	51-1/4"	26"	52-5/8"	26-1/2"	54-1/8"
18" + 36"	28-5/8"	56-3/8"	29"	57-3/8"	29-1/2"	59-3/8"
24" + 36"	31-5/8"	61-5/8"	32"	63"	32"	64-1/2"
12"+24"+36"	37-1/8"	71"	37-1/2"	72-1/2"	38"	74"

All measurements are in inches. Construction tolerances ± one inch.

NOTE:

- SuperVent/SuperPro chimneys are limited to offsets not exceeding 30 degrees. Combining offsets for greater angle is not permitted.
- One pair of (two) 15° or 30° elbows may be used per interior installation.
- Never install an elbow in a joist area. Chimney sections must pass vertically through framed joist areas.
- Locking bands must be use at all chimney joints of an offset.
- Elbow support will support 10 feet of chimney and the maximum length of chimney allowed between elbows is 6 feet.

CHART 2 - CHIMNEY HEIGHT ABOVE THE ROOF

Requirement # 1 : *The code requires that the chimney must extend at least 3 feet (900mm) above the highest point of the roof that it penetrates.*

Requirement # 2 : *It must also be 2 feet (609mm) above any roof, wall or other obstruction within a horizontal distance of 10 feet (3m).*

The following Chart is to assist you in determining the minimum chimney height you will require above the roof. You may need to add to this height as nearby buildings, trees and other parts of the house roof could interfere with airflow over and around the top of the chimney and affect its performance. If you think a nearby obstacle could affect draft, you might want to install one or more additional lengths.

DISTANCE FROM PEAK	PITCH OF ROOF											
	1/12	2/12	3/12	4/12	5/12	6/12	7/12	8/12	9/12	10/12	11/12	12/12
	CHIMNEY HEIGHT ABOVE ROOF (INCHES)											
10 Ft	*36	44	54	64	74	84	94	104	114	124	134	144
9 Ft	*36	42	51	60	69	78	87	96	105	114	123	132
8 Ft	*36	40	48	56	64	72	80	88	96	104	112	120
7 Ft	*36	38	45	52	59	66	73	80	87	94	101	108
6 Ft	*36	36	42	48	54	60	66	72	78	84	90	96
5 Ft	*36	*36	39	44	49	54	59	64	69	74	79	84
4 Ft	*36	*36	36	40	44	48	52	56	60	64	68	72
3 Ft	*36	*36	*36	36	39	42	45	48	51	54	57	60
2 Ft	*36	*36	*36	*36	*36	36	38	40	42	44	46	48
1 Ft	*36	*36	*36	*36	*36	*36	*36	*36	*36	*36	*36	36

*** Defaulted to 36" to meet requirement #1. Both requirements (#1 and #2) must be met.**

- If the chimney extends 5 feet or more above the roof, a Universal Roof Guy Kit (JURGK-1) is required.
- It is highly recommended that any lengths above the roof should have locking bands at all joints for added safety and stability. This will eliminate the risk of sections becoming undone below the roof line when the Rain Cap is removed when inspections and cleaning of the system is being done.

CHART 3 - Connector Pipe Clearance below Cathedral Support

1. Identify the type of connector pipe you will be installing, single wall (requires 18" clearance to combustibles) or Selkirk's Double Wall Stove Pipe (DSP) which requires 6" clearance to combustibles.
2. Determine the amount of the exposed Cathedral Support that will be projecting into the room as per the "X" in the diagram on the bottom left.
3. Select the pitch of your sloped ceiling from the chart below.
4. Select the measurement from the chart below where the pitch of the sloped ceiling column intersects with the exposed cathedral row selection. This will determine the measurement of insulated chimney required below the Cathedral Support as per the "Y" in the diagram on the right. The minimum of insulated chimney below the Cathedral Support is 1 inch. This minimum is required for stability of the system.

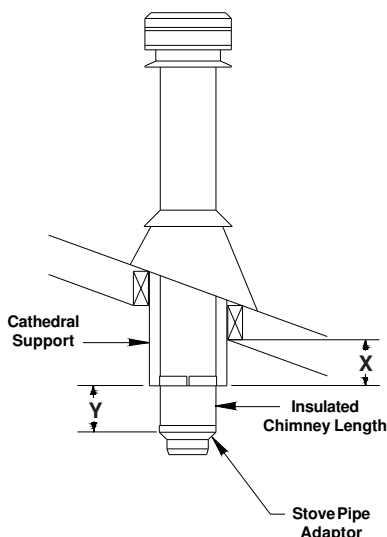

CONNECTOR PIPE CLEARANCE REQUIREMENTS FROM SLOPED CEILING													
EXPOSED CATHEDRAL SUPPORT INTO ROOM		PITCH OF SLOPED CEILING											
		1/12	2/12	3/12	4/12	5/12	6/12	7/12	8/12	9/12	10/12	11/12	12/12
1 Single Wall Flue Pipe	"X" measurement	"Y" MEASUREMENT - INSULATED CHIMNEY LENGTH INTO ROOM											
	Box flush to ceiling on lower end	1.5	3	4.5	6	8	9	10.5	12	13.5	15	16.5	18
	Box 1" into the room	1	2	3.5	5	7	8	9.5	11	12.5	14	15.5	17
	Box 2" into the room	1	1	2.5	4	6	7	8.5	10	11.5	13	14.5	16
	Box 3" into the room	1	1	1.5	3	5	6	7.5	9	10.5	12	13.5	15
2 DSP - Double Wall Stove Pipe	"X" measurement	"Y" MEASUREMENT - INSULATED CHIMNEY LENGTH INTO ROOM											
	Box flush to ceiling on lower end	1	1	1.5	2	2.5	3	3.5	4	4.5	5	5.5	6
	Box 1" into the room	1	1	1	1	1.5	2	2.5	3	3.5	4	4.5	5
	Box 2" into the room	1	1	1	1	1	1	1.5	2	2.5	3	3.5	4
	Box 3" into the room	1	1	1	1	1	1	1	1	1.5	2	2.5	3

¹ Single Wall Flue Pipe requires 18" clearance from any combustible materials.

² DSP Double Wall Stove Pipe requires 6" clearance from any combustible materials.

All measurements are in inches.

REPLACEMENT PARTS LIST

DESCRIPTION	SUPERPRO PART N°.	SUPERVENT PART N°.
36" Chimney Length	SPR*L36	JSC*SA3
24" Chimney Length	SPR*L24	JSC*SA2
18" Chimney Length	SPR*L18	JSC*SA18
12" Chimney Length	SPR*L12	JSC*SA1
6" Chimney Length	SPR*L6	JSC*SA6
Tee with Plug	SPR*ITP	JSC*SITS
Insulated Tee Plug	J*1TPI	J*1TPI
15° Elbow Kit	SPR*EL15K	JSC*SEK
30° Elbow Kit	SPR*EL30K	JSC*SE3K
Ceiling Support	SPR*CSB	JSC*DCS
Adjustable Wall Support	JSC*AWS	JSC*AWS
Adj. Interm. Wall Support	JSC*AIWS	JSC*AIWS
Cathedral Ceiling Support	SPR*CCSB	JSC*CCSB
Roof Support	JSC*RS	JSC*RS
Elbow Support	JSC*ES	JSC*ES
Locking Band	SPR*SLB	JSC*SLB
Stove Pipe Adaptor	JSC*ASE	JSC*ASE
Wall Thimble	SPR*WTB	JSC*WT
Trim Collar	J*TC	J*TC
Wall Band	JSC*WB	JSC*WB
Adjustable Ceiling Plate	JSC*CT	JSC*CT
Universal Roof Guy Kit	JURGK-1	JURGK-1
Adaptor Plate	JSC*AP	JSC*AP
Firestop Radiation Shield	JSC*FRS	JSC*FRS
Attic Insulation Shield	JSC*AIS	JSC*AIS
Rafter Radiation Shield	JSC*RRS	JSC*RRS
Finishing Plate	J*FP	J*FP
Deluxe Raincap	SPR*DRC	JSC*DRC
Standard Raincap	N/A	JSC*RC
Spark Arrestor	JSC*SPAR	JSC*SPAR
Flat Roof Flashing	JSC*ATC	JSC*ATC
1/12-6/12 Roof Flashing	JSC*AAF	JSC*AAF
6/12-12/12 Roof Flashing	JSC*AF2	JSC*AF2
Storm Collar	JSC*SC	JSC*SC

* Specify chimney size

Model Supervent and SuperPro chimney and components are listed to ULI 103HT and both manufactured by Selkirk Canada Corporation and as such are interchangeable with one and other.

LIMITED LIFETIME WARRANTY

Selkirk Chimney & Venting Products

Selkirk Canada Corporation, (“Selkirk”, “we”, “us”, “our”) warrants Selkirk products* to be free from defects in material and workmanship for as long as the original consumer owns the system. For products installed after January 1, 2000, for a period of Ten (10) years from original installation, we will provide replacement product with a similar or like quality of available Selkirk product, **free of charge** excluding any installation costs. From the Eleventh (11) through Fifteenth (15) years we will provide replacement product to the original consumer at a cost of 75% off the published Retail Price in effect on the date the claim is received excluding any installation costs. At expiration of the Fifteen (15) year term, we will provide replacement product to the original consumer at a cost of 50% off the published Retail Price in effect on the date the claim is received excluding any installation costs.

LIMITATIONS:

- Products must be installed for their intended purpose and in accordance with current Selkirk installation instructions.
- Products must be connected to an appliance listed with an accredited testing laboratory.

WARNING: FAILURE TO INSTALL SELKIRK PRODUCTS ACCORDING TO THE MANUFACTURER’S INSTRUCTIONS WILL VOID ALL APPLICABLE WARRANTIES AND MAY RESULT IN FIRE, CARBON MONOXIDE POISONING OR DEATH. SEE OUR SELKIRK INSTALLATION INSTRUCTIONS FOR COMPLETE INSTALLATION PROCEDURES.

WARRANTY COVERAGE:

This warranty covers any substantial defects in material and workmanship in normal use that are found to exist in any of the insulated chimney sections or component parts of your chimney with the exception stated below.

THIS WARRANTY DOES NOT COVER:

- (a) any non-stainless base tee unit mounted or connected to an Insulated Chimney system;
- (b) **costs (labor or otherwise **) associated with either removing a previously installed product, installing a replacement product, transportation or return of a product, or transportation of replacement product;**
- (c) damage to the finish of products caused by the use of improper solvents/chemicals or improper cleaning methods;
- (d) damage resulting from failure to reasonably clean, care for or maintain products in accordance with our installation instructions/recommendations;
- (e) damage (to products, appliances or structure on

- or resulting from improper installation or repair, misuse or abuse (including, but not limited to, excessive or improper operating condition), or alteration or adjustment other than in conformity with our installation instructions and specifications, whether performed by a contractor, service company, technician, or yourself;
- (f) any products that have been moved from their original installation site.
- (g) damage caused by burning driftwood, garbage, or any other prohibitive material which has been burned in the appliance served by the chimney
- (h) damage that results from accidents such as fire, flood, high winds, “acts of God”, or any other contingency beyond our control.

**** Due to the wide variance in installation practices and other conditions beyond our control, we do not guarantee or in any way warrant the installation of Chimney and Venting products.**

CLAIM PROCEDURE:

If you believe that a product is defective, notify us in writing at the following location:

SELKIRK CANADA CORPORATION

P.O. Box 526, Depot 1,
Hamilton, Ontario, Canada , L8L 7X6
ATTN: WARRANTY CLAIMS DEPARTMENT
905-662-6600, 800-263-9308, Fax: 905-662-5352

Notification should include a description of the product, model and serial number (if applicable) and a description of the product defect. Upon receipt of a written claim under this limited warranty and evidence of the date of purchase or installation, at our option and in our sole discretion, we will provide replacement product with similar or like quality of available Selkirk product excluding any installation costs. Selkirk Canada Corporation reserves the right to inspect or investigate any warranty claims prior to determining whether to provide replacement product. If, as determined by Selkirk Canada Corporation, repair or replacement of the product is not commercially practicable or cannot be completed in a timely manner, we may refund the purchase price paid for the product, prorated to the terms of this warranty, upon verification by providing a copy of your invoice or receipt of bill of sale.

INSTALLATION INFORMATION

Keep in a safe place for future reference

CHIMNEY MODEL: _____

INSTALLATION DATE: _____

DEALER
NAME: _____

Address: _____

City: _____

Province/State: _____

TECHNICIAN
NAME: _____

Address: _____

City: _____

Province/State: _____



PRODUCT REGISTRATION

Please register your Chimney with the Manufacturer.

Mail to: Selkirk Canada Corporation,
Warranty Registration, P.O. Box 256, Depot 1, Hamilton, ON L8L 7X6

or Fax: (905) 662-5352

Name: _____

Address: _____

City: _____

State: _____ Zip Code: _____ Telephone #: _____

Chimney Model: _____ Installation Date: _____

Technician Name: _____ Address: _____

City: _____ State: _____ Zip Code: _____ Telephone #: _____