

L-Vent / Vent System for Pellet Burning Appliances

Installation Instructions

Covering - General Installation Instructions & Owner's Maintenance Guide

A MAJOR CAUSE OF VENT RELATED FIRES IS FAILURE TO MAINTAIN REQUIRED CLEARANCES (AIR SPACES) TO COMBUSTIBLE MATERIALS. IT IS OF THE UTMOST IMPORTANCE THAT THIS DOUBLE WALL VENT SYSTEM BE INSTALLED ONLY IN ACCORDANCE WITH THESE INSTRUCTIONS.

Read all instructions before beginning the installation. Failure to install this system in accordance with the instructions will void manufacturer's warranty and may result in an unsafe installation. Keep these instructions for future references.

⚠ WARNING

Failure to follow the installation instructions could cause FIRE, CARBON MONOXIDE POISONING, OR DEATH. If you are unsure of installation requirements, call the telephone number listed on these instructions, or visit our website www.selkirkcorp.com.

1. VENT SYSTEM PARTS AND NUMBERS

Figs. 1,2, 3 and 4 show the names and locations of commonly used Model VP parts. On these and other figures which are present throughout this document, only the last portion of the part number is used. The complete part number is prefixed with I.D. size, system identifier and part identifier.

For Example:

Model VP System

Inside Diameter - - **4 VP-TS** - Standard Tee

Model VP System

Inside Diameter - - **4 VP-60** - 60" Pipe Length

2. SIZES AND APPLICATIONS

Selkirk Model VP L-Vent is manufactured in 3" and 4" I.D. sizes. L-Vents installed in accordance with these instructions comply with National Safety Standards such as NFPA 211 in the US and CSA-B365 in Canada. When Model VP L-Vent System is used for venting gas or oil fired appliances refer to NFPA 54 for gas and NFPA 31 for oil. In Canada refer to CSA-B139 for oil and CSA-B149 for gas.

3. MODEL VP SAFETY CERTIFICATION

Model VP has been tested and listed by Underwriters Laboratories, Inc. in accordance with UL641, the Standard for Type L Low Temperature Venting Systems, in addition to certain other applicable requirements from UL103, the Standard for Residential Type and Building Heating Appliance Chimneys. Model VP is tested and listed to Canadian Standard CAN/ULC-S609 for Low Temperature Vents Type L (gas and oil) and and Type PL for pellet in which the maximum continuous flue gas outlet temperatures does not exceed 570°F (300° C).

4. MINIMUM CLEARANCE- AIRSPACE ONLY

All Model VP flue gas carrying parts are marked with clearance information as follows:

MAINTAIN MINIMUM 1" AIRSPACE CLEARANCE TO COMBUSTIBLES in the U.S. and **MINIMUM 3" AIRSPACE CLEARANCE** in Canada.

"Combustibles" include framing lumber, drywall, plaster, plywood, paneling and other building materials.

In addition to the airspace clearance specification, each section of vent is marked with an "UP" arrow indicating the intended direction of flow (i.e. end which should be oriented AWAY from the appliance). Auxiliary parts such as combination Ceiling Support/Firestop Spacers, Trim Plates, Flashings and Wall Thimble outer shields are intended to be attached directly to the framing or to ceilings, floors, or walls in accordance with their respective instructions. These parts, which are installed in contact with wood or other combustibles, are designed and tested to assure that they do not overheat at points of contact.

Table 1 gives the proper framing dimensions, which in turn define the proper clearance. Wherever these instructions illustrate the use of a required spacer, thimble or firestop, the purpose of the part is to maintain and assure the proper clearance.

Table 1
Minimum Clearance and Framing Dimensions

Vent Size	Clearance (US)	Framing (US)	Clearance (Canada)	Framing (Canada)
3"	1"	9-1/2" x 9-1/2"	3"	9-1/2" x 9-1/2"
4"	1"	10-1/2" x 10-1/4"	3"	10-1/2" x 10-1/2"

Table 1 gives the proper framing dimensions, which in turn define the proper clearance. Wherever these instructions illustrate the use of a required spacer, thimble or firestop, the purpose of the part is to maintain and assure the proper clearance.

Remember that clearance requirement is AIR SPACE ONLY.

5. ENCLOSURES

The vent system should be enclosed in occupied areas, closets, storage rooms, and accessible attics. Enclosures may be built of ordinary drywall or plywood at the required minimum AIRSPACE CLEARANCE (See Table 1). There are no special parts to maintain clearance to inside surfaces of walls or enclosures. Therefore, the vent installer should take all necessary precautions to assure that this minimum airspace is maintained.



In unoccupied attics, it is very important to be sure that blown-in or other insulation does not come in contact with the vent system. An attic insulation shield should be installed where the vent passes into an attic space. The height of the attic insulation shield is to meet the insulation level requirement of the National Building Code. Where height restrictions will not permit the use of the attic insulation shield, it is permissible to construct an enclosure with the appropriated air space clearance to the outer pipe all the way to the underside of the roof deck (see Table 1). In this application you need to install a finishing plate on the ceiling side. A full enclosure in the attic should extend to the roof. However, it need only be finished well enough to keep insulation and stored furnishings away from the vent system. NOTE - Enclosures maintaining the minimum airspace clearance are especially important in attics insulated with CELLULOSE type insulation which may be composed of old newspapers and other cellulose materials which are very susceptible to ignition of a fire.

A vent system enclosure is also recommended for any exterior systems and portions extending through unheated areas. This enclosure is helpful in reducing internal condensation, residual buildup from products of combustion and metal deterioration. Also the enclosure, by protecting the vent from cold outdoor temperatures, may improve draft and appliance operation. At the upper end of an outdoor enclosure the vent system should be finished off with a flashing, storm collar and vent cap as described elsewhere in these instructions.

Regardless of the benefits of the exterior enclosure, better vent and appliance operation will be obtained if the vent is located entirely inside the heated portion of the building (except of course for the part above the roof). A vent must be enclosed in any inhabited space above the appliance. In a building other than a one or two family dwelling, the enclosure material shall have a fire resistance rating at least equal to the adjacent floor or ceiling material.

CERTIFICATION LABELS

 LISTED MH7647 TYPE L and PL LOW TEMP VENTING SYSTEM ÉVÉNEMENT À TEMPÉRATURE BASSE PELLET VENT ÉVÉNEMENT POUR POÊLE À GRANULES UL 641 CANULC-5600 12 0015550	 GRAND RAPIDS, MI MODEL VP MODELE For interior use, Exterior use Above the Roof Line, Enclosed Exterior. Pour usage intérieur, usage extérieur hors-toit, usage extérieur dans une enclosure. Maintain minimum 1" (25mm) air space clearance to combustible materials in the U.S. and 3" (76mm) in Canada. Also may be used to vent listed pellet burning appliances. WARNING - Suitable only for connection to wood pellet, oil or gas fired appliances producing flue gas temperatures between 212 Deg F (100 Deg C) and 570 Deg F (300 Deg C). Do not connect to any other type of appliance. Install and use only in accordance with Selkirk installation and maintenance instructions. Maintenez un dégagement d'air minimum de 1 po (25mm) des matériaux combustibles au États-Unis et de 3 po (76mm) au Canada. Peut aussi être utilisé pour ventiler les appareils à granulés. AVERTISSEMENT - raccorder uniquement aux appareils à granulés de bois, huile ou au gaz produisant des gaz de combustion entre 212deg F (100deg C) et 570 deg F (300 deg C). Ne pas raccorder sur tout autre appareil. Installer et utiliser selon les directives d'installation de Selkirk. WARNING Failure to follow the installation instructions could cause FIRE, CARBON MONOXIDE, POISONING, OR DEATH. If you are unsure of installation requirements, call the Phone Number listed on the instructions, or sizing handbook, or visit www.selkirkcorp.com. AVERTISSEMENT Ne pas suivre ces instructions d'installation peut causer FEU, EMPOISONNEMENT AU MONOXYDE DE CARBONE OU LA MORT. Si vous êtes incertains sur les procédures d'installation, veuillez communiquer au no. de téléphone inscrit sur les instructions ou visitez notre site www.selkirkcorp.com.
	LABEL SAMPLE  1 23456 78901 2 8/16/18

 LISTED MH7647 TYPE L and PL UL 641 CANULC-5600 LOW TEMP VENTING SYSTEM ÉVÉNEMENT À TEMPÉRATURE BASSE PELLET VENT ÉVÉNEMENT POUR POÊLE À GRANULES 12 0015551	 GRAND RAPIDS, MI MODEL VP MODELE Do not connect to any other type of appliance. Install and use only in accordance with Selkirk installation and maintenance instructions. Ne pas raccorder sur tout autre appareil. Installer selon les instructions d'installation de Selkirk. WARNING Failure to follow the installation instructions could cause FIRE, CARBON MONOXIDE, POISONING, OR DEATH. If you are unsure of installation requirements, call the Phone Number listed on the instructions, or sizing handbook, or visit www.selkirkcorp.com. AVERTISSEMENT Ne pas suivre ces instructions d'installation peut causer FEU, EMPOISONNEMENT AU MONOXYDE DE CARBONE OU LA MORT. Si vous êtes incertains sur les procédures d'installation, veuillez communiquer au no. de téléphone inscrit sur les instructions ou visitez notre site www.selkirkcorp.com.
	LABEL SAMPLE  1 23456 78901 2 9/16/19

6. YOUR CHOICE OF HEATING APPLIANCE

There are three important rules for selecting a gas or pellet burning appliance. **FIRST:** Look for a label or nameplate attached to the appliance which bears the mark of a well known safety testing organization, such as Underwriters Laboratories, American Gas Association, etc.

SECOND: Don't buy an appliance which is larger than necessary.

THIRD: Look or ask for complete installation, operating and maintenance instructions for the appliance. If you can't get these, buy one that includes all these very important details.

7. APPLIANCE SAFETY

Be sure to follow all details of the instructions provided with your appliance. Especially note and follow recommended installation clearances and operating instructions.

Do not mix and match with other manufacturer's products. Use only VP listed components.

8. VENT SIZE, HEIGHT AND TERMINATION

Before beginning installation of the vent system, be sure that the selected size is adequate for the appliance and the selected height of the Model VP termination is sufficient to conform to building code requirements and the termination height guidelines given elsewhere in these instructions.

9. A NOTE ABOUT PRODUCTS OF COMBUSTION FROM PELLET BURNING APPLIANCES

One of the most common, visible products of combustion from many pellet burning appliances is a fine, powdery dust which may tend to accumulate near the outlet of the vent and/ or at the joints within the vent. While this material is believed to be non-combustible, it should not be permitted to

accumulate within the system since significant accumulation could begin to affect both the vent system's ability to function properly and the heating appliance operation. Accordingly it is recommended that the system be inspected periodically for the build-up and cleaned if necessary. In order to help minimize the accumulation of this powder within the system, each vent section is provided with a hi-temperature fiberglass rope gasket within the annulus of the female end. This gasket helps minimize air movement through joints, thereby enhancing the draft through the vent system and minimizing the powder accumulation.

10. USE OF SEALANTS

(OPTIONAL IN U.S.A. MANDATORY IN CANADA)

Model VP has been listed for use with high temperature silicon sealant applied to the male end and seams of the vent section just prior to installation. This sealant in conjunction with the rope gasket, further reduces air infiltration, minimizing accumulation of the powder.

Vent systems incorporating tee sections, 90 degree elbows and/ or tall heights are most susceptible to the powder accumulation and should be inspected and cleaned more frequently. Use only high temperature sealants such as Dow Corning's Silastic 732 RTV or Firestop sealant, or comparable, rated for use at a minimum of 450 degrees F (232deg. C).

NOTE: Model VP Elbows are NOT adjustable.

11. RULES FOR SAFETY DURING INSTALLATION

- Wear safety glasses when sawing, nailing, or using other power tools.
- Wear gloves when handling sheet metal parts with sharp edges.
- Be sure all electrical tools are properly grounded.
- Be very careful when cutting openings and working in the area where electrical wiring is located. Wiring should be secured at least 3" away from the outer surface of any vent section. If wiring must be relocated, have this done by a qualified electrician.
- Ladders, where necessary, should be in good condition and set upon a firm, level surface.

12. VENTING MORE THAN ONE APPLIANCE

In certain instances more than one gas or oil fired appliance may be connected to the same vent system. Be sure to follow the appliance manufacturer's recommendations and local fire and building code requirements if this is planned. UNDER NO CIRCUMSTANCES should a pellet burning appliance be connected into the same vent system as any other type of appliance. NOTE: The Pellet Pipe from one or more appliances may be installed vertically inside a dormant masonry flue, or dormant certified chimney, or a dormant in vent, provided each appliance is equipped with its own individual vent installed in accordance with the manufacturer's requirements.

13. SUPPORT

Model VP vent system must be securely supported. Lateral runs are to be supported at least every 5 feet. When offsets are necessary, adequate support above and below the offset is required. In addition it is recommended that each offset elbow be secured with a minimum of two sheet metal screws at the joint. (See "Vent Section Interconnection"). Vertical runs are normally supported by the combination Ceiling Support/ Firestop Spacers. Short vertical vents with less than 6 feet of vertical vent below the flashing may be suspended from the flashing. In such case, the vent may be supported by the storm collar resting on the top of the flashing, using 1/4" long sheet metal screws to attach the storm collar to the vent at the appropriate place. Vents supported only by the flashing must be guyed above or below the roof to withstand snow and wind loads. All vents extending above the roof more than 5 feet must be securely guyed or braced.

14. GENERAL INSTALLATION INSTRUCTIONS

VENT SECTION INTERCONNECTION

Each flue gas carrying section of Model VP is designed with a male and female end coupling. To join sections simply push mating ends together until the locking tabs engage, preventing them from being pulled apart. If additional securement is desired, one or more, maximum 1/4" long sheet metal screws may be used at the joints. Being careful not to drill through the stainless steel inner wall of the vent, first drill a 3/32" hole approximately 3/8" above the line of the joint. Then install the screw(s). NOTE: Anytime sections of Model VP are supported only from above, the use of these additional screws is recommended to prevent unintended disengagement of vent sections.

COMMON TYPES OF INSTALLATIONS

Figs. 1 through 4 show four common types of installations of the Model VP vent system. These figures provide a reference for reviewing common applications for the various system parts.

NOTE: See Table 1 for Minimum Clearances

INSTRUCTIONS FOR INSTALLING VENT

Refer to "Common Considerations" section for a list of items that should be taken into consideration before beginning any installation.

Locate appliance per Manufacturers recommendations, making sure to maintain specified clearances to combustibles.

Attach Pipe Connector (PC) per section on "Pipe Connector" (See Figs 1-4). If the vent planning was to include a vertical rise, a Tee Section (TS) can be used to turn the vent vertical (see Figs 2 & 3). Position tee so that it is vertical, and the cleanout tee cap is at the bottom. Attach tee to vent. Connect additional vent sections to route the system out of the building. See "Adjustable Length" section for situations where a non-standard length of pipe is necessary.

Refer to "Wall Bracket Support" (WB) section for instructions for providing support for the vent system (See Fig 3).

For vertical penetrations see section on "Vertical Penetrations" for proper installation (See Figs 1 & 2).

For Horizontal Wall penetrations, see section on "Wall Thimble" for proper installation (See Figs 3-4).

If a Tee and Tee Support was included in the planning, see section entitled "Tee and Tee Support" for proper installation (See Fig 3).

When terminating vertically through the roof, see sections on "Roof Flashing", "Storm Collar", & "Vertical Termination Cap" (See Figs 1-3).

When terminating horizontally through a wall, See section on "Horizontal Termination Cap" (See Fig 4).

See sections 15 & 16 for installation instructions on painting the product and maintenance requirements.

COMMON CONSIDERATIONS

The following comments apply to all types of installations.

1. The intended installation location of VP is for interior use or exterior above a roof line or exterior enclosed.
2. The installation of Model VP shall facilitate cleanout and removal of parts for examination, repair and maintenance.
3. Before beginning any installation, select the desired location for the appliance, being sure to maintain the appliance manufacturer's specified minimum clearances. Try to minimize the amount of work by choosing a location where framing members in the walls and floors will not interfere with the intended vent location or the required airspace clearances.
4. Where possible, minimize the length and total number and degree of offsets in your vent system in order to permit the system to vent optimally. Use of too many offsets may result in poor draft and may affect the performance of the appliance. If it is necessary to include many offsets and/ or extensive lengths of vent, consider use of an additional joint sealant. (See "Optional Joint Sealant") in order to optimize available draft for the system's configuration.
5. Throughout these instructions, where preparation of an opening for passage of Model VP through walls is referenced, we recommend cutting and FRAMING the opening to the appropriate size. While framing is not necessary in all cases, it is recommended in order to maintain the integrity of the structure and provide sufficient anchoring for fasteners, especially where support assemblies will be installed.
6. Framing of the opening is required for all vertical penetrations where a firestop is specified, in order to provide adequate fire-stopping.
7. Proper planning for your Model VP vent installation will result in greater safety, efficiency and convenience, saving time and money.
8. Use ONLY Selkirk Model VP listed parts.
9. DO NOT INSTALL damaged parts.
10. PERMITS are required in most areas. Contact your local building code and/ or fire officials regarding permits, restrictions, and installation inspections in your area BEFORE you begin your installation.
11. At the level where the vent penetrates the air/vapour barrier, special attention is required. Seal the vapour barrier to the ceiling support pade, trim pade or wall thimble using an appropriate caulking compound as per the requirement of local authorities.
12. The rain cap of a vertical (through the roof) installation must be at least 36" (900mm) above the roof line.

YOUR SPECIFIC INSTALLATION REQUIREMENTS

Now that you have an overview of the system parts and optional types of installations, you are ready to plan an installation to meet your specific needs. We suggest proceeding as follows:

1. Carefully review your options for the installation and select a tentative location and vent system configuration. This may be similar to one or a combination of Figs. 1 through 4.
2. Review the appliance installation instructions and determine whether the location and vent configuration you selected are suitable, convenient and attainable. Plan to incorporate parts which will facilitate inspection and cleaning.

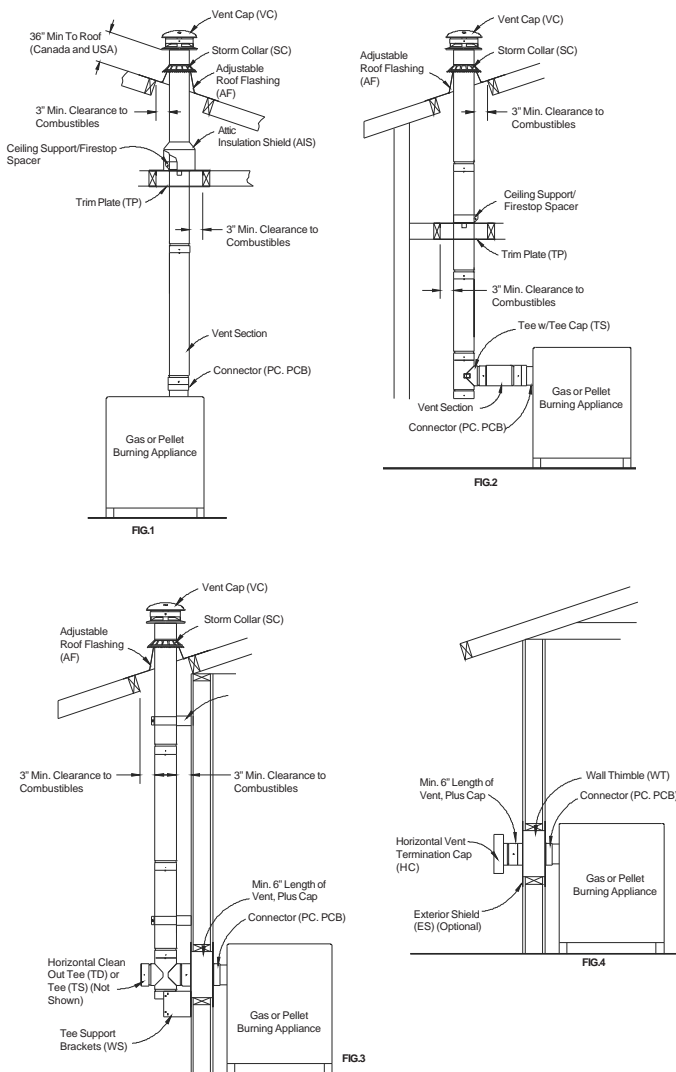

3. After you are satisfied with the location and configuration, plan the exact layout, identifying all component parts, sizes and dimensions you will need to complete the installation. Check to insure that you have access to all parts and accessories you will need.

4. If you have not already obtained the necessary permits for the installation, do so before proceeding further.

5. Accumulate all the parts you plan to use along with the tools, equipment and supplies you may need to complete your work.

These may include:

Eye Protection	Hammer
Gloves	Assorted Nails
Tape Measure	Assorted Wood Screws
Marking Pencil	Ladder
Circular Saw	Plumb Bob
Screwdriver	Razor Knife
Extension Cord	Level
Hand Saw	Pliers
Square	Electric Drill
1/8" or 3/32" drill bit	Caulking Gun
"Stud Sensor" or similar device (for locating framing)	
Keyhole, Jig, Sabre or Reciprocating Saw	
High Temperature silicon sealant	
Non-hardening waterproof mastic or caulking	

6. If space permits, install the appliance and begin installing the vent system directly at the appliance flue collar and work toward the termination. If space does not permit, plan the exact location of your appliance and determine the exact lengths of system components which will extend between your appliance flue collar and the wall or ceiling you will penetrate. Begin the installation of the vent system at this location and work in each direction until the installation is completed by moving the appliance into position and making the final connection between the appliance flue collar and the pipe connector.

7. As necessary, refer to these detailed instructions for installation of the various component parts, being careful to maintain the required clearances to combustible construction.

8. Upon completion of your installation, check to see the exterior portions of the vent systems are properly installed and protected from weather. Check to see that all system components are securely attached and installed in accordance with the instructions.

9. Install any necessary enclosures in occupied areas and in attics to help insure that the system is not damaged and that the required airspace clearance to combustibles is maintained. (See "Enclosures").

RULES FOR DISTANCES FROM HORIZONTAL EXIT TERMINATIONS

In selecting the location for the appliance and the vent, it is necessary to take into account the rules of NFPA 211 (USA) and CAN/ULC-S609 (Canada). Before beginning any installation which will result in a vent cap being installed adjacent to the side of a structure:

1. Check to confirm that local fire and safety codes permit this type of installation. If so, install per code requirements.

When installed in the USA:

2. In the absence of overriding local requirements, use the following National Fire Protection Association Standard 211 guidelines for distances from the exit termination to doors, windows, air inlets, etc.:

The exit terminal of a mechanical draft system, other than a direct vent appliance (sealed combustion system appliance), the termination shall be located in accordance with the following:

A. Not less than 3 ft. (0.91 m) above any forced air inlet located within 10 ft. (3m).

B. Not less than 4 ft. (1.2m) below, 4 ft. (1.2m) horizontally from, or 1 ft. (305mm) above any door, window or gravity inlet into any building, and

C. Not less than 2 ft. (0.6m) from adjacent building and not less than 7 ft. (2.1m) above grade when located adjacent to public walkways.

When installed in Canada:

The Termination of a side-wall vent shall be located to avoid personal burn injury, fire hazard, and interference with or damage to adjacent properties. The following restrictions applies:

A. Vent Length must not exceed 1200 mm (48") or the maximum length specified by the manufacturer;

B. The minimum and maximum equivalent length of the through-the-wall venting system shall be in accordance with the certified appliance manufacturer's instructions;

C. Within 1.8m (6 ft) of a mechanical air supply inlet to a building;

D. Above a gas meter/regulator within 900 mm (36") horizontally of the vertical centre of the regulator;

E. Within 1.8m (6 ft) of a gas service regulator vent outlet or within 1 m (3 ft) of an oil tank vent or an oil tank fill inlet;

F. Less than 300 mm (12") above grade level or any adjacent surface that might support snow, ice, or debris;

G. Within 1 m (3 ft) of a building opening (windows and doors) or air inlet of another appliance;

H. Not less than 600 mm (24 ft) from adjacent building and not less than 7 ft. (2.1m) above grade when located adjacent to public walkways, lane, street, right-of-way, stairway, or landing;

I. Directly above a paved sidewalk or paved driveway that is located between two single-family dwellings and serves both dwellings;

J. Within 1.8 m (6 ft) of the property boundary;

K. Within 1 m (3 ft) horizontally of the vertical centre line of a gas service regulator;

L. In any enclosed or semi-enclosed areas such as a carport, garage, attic, crawlspace, narrow walkway, closely fenced area, under a sundeck or porch, or any location that can built up a concentration of fumes such as stairwells, covered breezeway, etc.;

M. Underneath a veranda, porch or deck, where the veranda, porch or deck is not fully open on a minimum 2 sides beneath the floor and the distance measured between the top of the vent to the underside of the veranda, porch or deck is greater than 300 mm (12");

N. Less than 1200 mm (48") beside or below any door or window that may be opened, or less than 450 mm (18") if outside fresh air is installed;

O. Less than 300 mm (12") above any door or window that may be opened, or less than 230 mm (9") if outside fresh air is installed;

P. Less than 600 mm (24") below any ventilated eave or roof overhang, or less than 450 mm(18") below any unventilated eave or roof overhang;

S. Less than 300 mm (12") to an outside corner, and less than 300 mm(12") to an inside corner of a combustible wall;

T. Guards shall be provided around the termination of the side-wall venting system to prevent contact and physical damage.

COMMON VENT SYSTEM PARTS AND THEIR INSTALLATION

PIPE CONNECTOR (VP-PC, VP-PCB, VP-MFC, VP-APC)

The Pipe Connector is a ("starter section") fitting used to connect the flue collar of the appliance to the Model VP vent system. Available in black (PCB) or unpainted (PC), the connector consists of a single wall cylindrical piece of stainless steel (which is attached to the flue collar of the appliance) on one end and a short double wall section of vent on the opposite end which incorporates a coupling for attachment to other Model VP vent sections. To install: depending upon the appliance flue collar, insert the Pipe Connector into or over the appliance flue collar and attach with a minimum of two screws. A drill with 3/32" bit may be used to drill through the collar and into the connector. The Adjustable Pipe Connector (APC) and Multi-Function Connector (MFC) have an adjustable hose clamp on the inlet end to connect to the flue collar without the use of supplemental screws. The MFC is used to connect to and increase a 3" diameter flue collar to 4" diameter vent. To install, slide the inlet end of the APC or MFC over the flue collar. Apply sealant to the flue collar. Tighten the hose clamp on the connector (sealing and securing) the APC or MFC to the appliance flue collar.

ADJUSTABLE LENGTH (VP-EZAJ12)

Adjustable lengths are designed to be telescoped over a fixed length of vent in order to create an assembly of specific length. Being an overall length of 12", the adjustable length may be used in vertical, horizontal or sloped configurations but should not be depended upon to support any lengths of pipe beneath.

To install:

Guide the bottom end of the adjustable length down over the upper end of a straight section in such a manner as to let the inner flue of the adjustable length slide inside the flue of the fixed section and the outer wall slide down over the outer wall of the fixed length section. When the desired length is achieved by this combination, install two 1/4" long screws provided through pre-punched holes in the outer. Take care not to pierce inner when drilling outer of VP on lower section to secure the two lengths and prevent slippage. Note - The adjustable length is commonly used in conjunction with a straight section and the pipe connector in order to attain a specific length of vent for adapting the system to a specific placement of the appliance.

WALL THIMBLE (VP-WT)

A Wall Thimble (WT) must be used for all through-the-wall installations involving combustible construction. The standard Wall Thimble is designed to accommodate wall thicknesses of 4" to 7" while the "Thick Wall" Thimble (WTT) will accommodate thicknesses of 6-1/2" to 11-1/2", and may be installed in direct contact with combustible framing, insulation and other materials. See Table 1 for Framing requirements.

NOTE: The Thimble is shipped in the fully engaged position. Prior to installation, you must disengage the thimble halves. Disengage by rotating the face plates in a counter clockwise direction (CCW) (unscrew the two halves). See Fig 5.

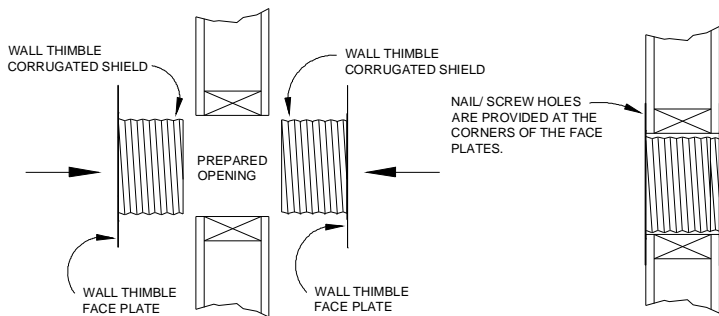

Fig. 5 WALL THIMBLE INSTALLATION

To Install:

After preparing the proper sized opening (See Table 1), insert the two halves of the wall thimble from opposite sides of the wall and engage by rotating the face plates in a clockwise direction (CW) until a snug fit is achieved. If a tee section with support brackets is to be installed on one side of the wall penetration, it is recommended to frame the opening. The thimble is now installed and ready to receive a section of vent. Slide vent through Wall Thimble (See Fig 5).

TEE (VP-TS, VP-TD)

Tee sections are designed for use in changing the orientation of the vent from horizontal to vertical and to make cleaning of the system easier than if a 90 deg elbow is used. The tee is provided with a cap on the bottom (VP-TS) and on one side (VP-TD, only) held in place by a friction fit and a screw stop.

To install:

Depending upon the particular installation, the tee is either attached to a tee support assembly (see Fig. 3) or simply suspended behind the appliance and supported by a combination of the appliance and support from above (see Fig.2). In either case, common sections of vent are attached to the tee inlet and outlet by simply inserting the mating ends until the tabs engage. In Fig 2 type installation and anytime the tee is supported from above, it is recommended that screws be added to the joints at the inlet and outlet of the tee, in order to prevent unintended joint separation.

TEE SUPPORT (VP-WS)

NOTE: The tee support is optional and should not be installed until the wall thimble has been completed. IF the tee support is not used, a wall bracket/ support **MUST** be used within 6" to 12" above the tee and the tee inlet and outlet joints must be secured with screws as indicated under "Vent Section Interconnection".

The tee support kit consists of two (2) symmetrical plate brackets (designed to accommodate either a 3" or 4" diameter tee), four (4) wood screws (for attaching the brackets to the wall), and two (2) hex head sheet metal screws (for attaching the support brackets to the tee).

To Install:

1. Referring to Fig. 6, first draw a pencil line on the outer faceplate of the thimble, extending horizontally through the center of the hole.
2. Measure down 5-1/2" and draw a second horizontal line. This line, which is over the center of the lower framing member, will be used to locate the topmost screws (location "C" in Fig. 6) for the support brackets.
3. Using the left and right upper edge of the hole in the wall thimble face plate as a starting point, draw vertical lines which extend down to and intersect the lower, horizontal pencil line.
4. Referring to Fig. 6, orient the support brackets as shown and attach each to the bottom left and right side of the tee using a hex head screw routed through the appropriate holes in the support brackets ("A" or "B" from Fig. 6) and into the 1/8" hole provided in each side of the tee, approximately 1" up from the bottom. Rotate brackets to the approximate position shown. Engage screws partially.
5. Insert the pre-selected horizontal section of vent into the inlet of the tee, pushing it in until the tabs snap lock into place.
6. From the outside insert the open end of the horizontal section (with tee attached) through the opening in the wall thimble.
7. Orient the support brackets as indicated and situate so that hole "C" in each support bracket is positioned over the lower horizontal pencil line and the inside (vertical) edge of each bracket is in approximate alignment with respective vertical pencil lines extending down from the edges of the hole in the wall thimble.
8. Once properly situated, secure brackets to wall with four (4) wood screws (provided) using holes "C" and "D". Note that the top hole on the flange of each bracket is not used.
9. Check to see that the correct holes have been used by measuring to verify that the brackets establish the required airspace between the outside wall and the tee, then tighten all fasteners.

WALL BRACKET/ SUPPORT (VP-WB)

The combination Wall Bracket/ Support is designed to provide both lateral and vertical support for a vent system which is installed adjacent to a wall. In addition, properly installed, they provide for the required clearance from the wall. One VP-WB should be installed 6" to 12" above a tee if the optional tee support is not used and within the first 8' if a tee support is used. Additional VP-WB assemblies should be used at maximum 8' intervals as the vent system is routed up the wall. Wall brackets/ supports may be installed as the individual sections are being installed or they may be pre-installed, centered over a projected center line of the vent system on the wall of the structure.

To Install:

(Refer to Fig. 7) - After properly locating the bracket on the wall, simply attach the bracket to the wall using the screws provided. A vent section may be inserted within the collar either before or after attachment to the wall. In either case, be sure adjacent vent sections are properly joined together, then simply tighten screw/ nut assembly on collar until collar tightly secures vent section in place.

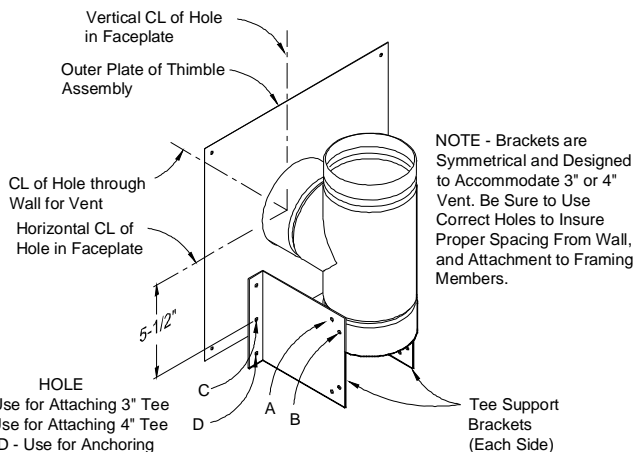

FIG. 6 TEE SUPPORT BRACKET

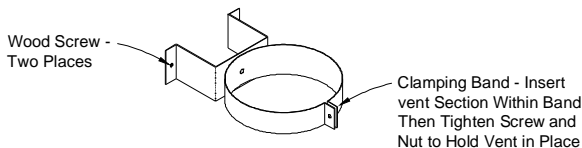

FIG. 7 WALL BRACKET/SUPPORT

VERTICAL PENETRATIONS:

CEILING SUPPORT / FIRESTOP SPACER (CS)

A Ceiling Support / Firestop Spacer (CS) must be installed where the vent passes through a ceiling or floor joist. The CS provides vertical support for the vent system and maintains the minimum 3" clearance to combustible materials.

If the location where the vent passes through the ceiling is visible, a Trim Plate (TP) may be desired in order to provide a finished look to the penetration.

To install:

Determine the location where the vent will pass through the ceiling. Prepare an opening in the ceiling (See Table 1 for proper framing dimensions). From the top side of the joist, set the CS plate into the framed opening so that the 4 tabs on the plate extend down into the opening. These tabs help verify that the minimum clearance to framing is established. Nail the CS plate to the framing members (See Fig 8). If installing a Trim Plate (TP), center the TP on the ceiling (bottom side) of the opening and secure to the framing members using appropriate fasteners such as with four (4) #8 x 1-1/2" panhead black wood screws (not included). See Support Band section to complete installation.

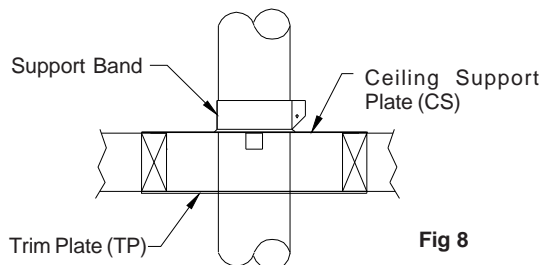

Fig 8

CATHEDRAL CEILING SUPPORT (CCS)

The Cathedral Ceiling Support (CCS) may be used in pitched or flat ceiling installations and comes with a Support Collar and a decorative two part square Trim Plate. Install by inserting the Support Box down through the framed joist opening (end with round hole first) in the ceiling. Using tin snips, cut the corners of the open end of the box such that the sides can be folded down over the top of the joist framing members. Nail the folded sides to the top of the framing. Slide the Support Collar over pipe and place pipe through hole to determine proper elevation of pipe. Once proper elevation is determined remove pipe from support box and secure collar to pipe with nut & bolt, (drawing tabs together), securely clamping collar to pipe at location previously determined to provide proper pipe elevation. Insert 1/4" screws (provided) through pre-punched holes in collar and into outer wall of pipe to prevent any slip. Re-insert pipe through support box opening until support collar (now attached to the pipe) rests on bottom of support box. Add lengths of pipe as appropriate.

A two-part square Trim Plate is provided to give a finished look once installed. Simply fit the two halves of the Trim Plate around the Cathedral Ceiling Support Box hanging below the ceiling (overlapping if necessary) and screw them to the ceiling. The Cathedral Ceiling Support can support a maximum of 40 feet of pipe.

Framing details are as follows:

- Flat ceiling = 10 5/8" x 10 5/8" square.
- Pitched ceiling = 10 5/8" x some dimension so as to create a rectangular framed opening suitable to accept the CCS.

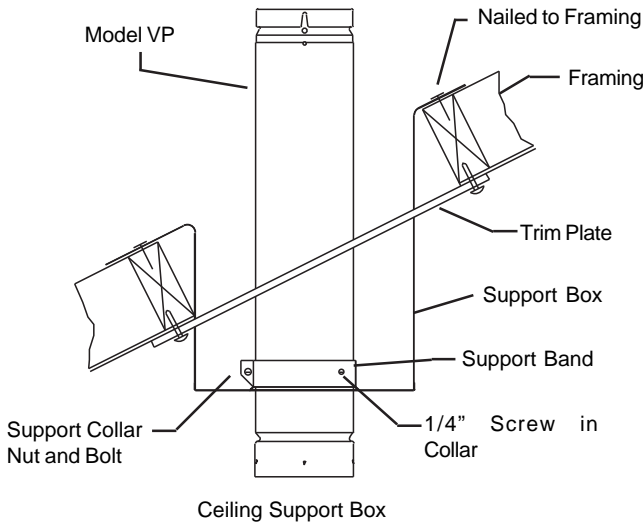

FIG. 9

SUPPORT BAND

The Support Band is used to secure the vent pipe to the plate on the CS. After the CS plate is installed, route the vent pipe up through the hole in the CS plate. Position the Support Band so that the larger, flanged edge is to the bottom and slide the support band down over the vent pipe until it is in contact with the CS plate. Using a screwdriver, tighten the bolt on the Support Band to draw the ends together and clamp to the vent pipe (See Fig 8).

ATTIC INSULATION SHIELD (AIS)

When Model VP enters an opened attic space, install an Attic Insulation Shield around the pipe. The Attic Insulation Shield is to prevent any debris or blow-in insulation from coming in direct contact with the pipe. It must accommodate the amount of insulation height as required by the National Building Code. If it is not practical to use an Attic Insulation Shield (due to height restriction or too high of an insulation depth) it is permissible to construct an enclosure with the required air space clearance (see Table 1) to the outer pipe all the way to the underside of the roof deck. Install a trim plate on the ceiling side. Install the AIS by slipping it down over the vent extending through the attic floor and securing to the floor with nails.

ELBOWS - 45 DEG (VP-45EL), 90 DEG (VP-90EL)

Model VP provides 2 types of elbows, a 45 (VP-45EL) and a 90 (VP-90EL), see Fig. 10. These are used to accommodate unusual offsets and configurations. The elbows are designed with the same end couplings as the straight sections in order to facilitate their use anywhere in the system. NOTE: Elbows are NOT adjustable. When offsets are necessary, adequate support above and below the elbows is required.

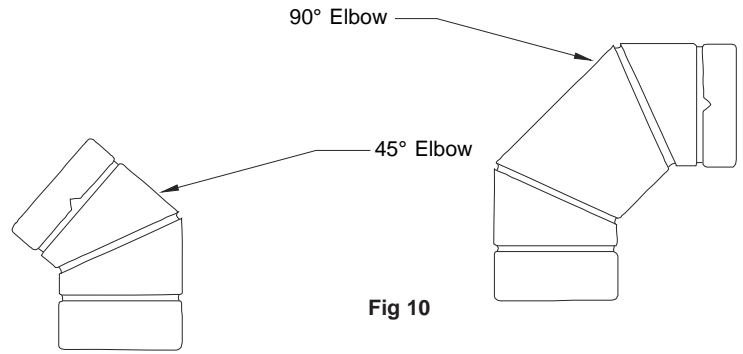

Fig 10

ROOF FLASHINGS - TALL CONE (VP-TF), ADJUSTABLE (VP-AF)

Roof flashings are used to provide a transition at the roof through which the vent will pass and to protect the interior of the structure from weather. The VP-TF is intended for use only on flat roofs while the VP-AF is designed for use on roofs having a slope of 0/12 (flat) to 6/12. Flashings are always used in conjunction with a storm collar (VP-SC).

To install:

After determining the exact location where the vent assembly will penetrate the roof, cut hole which will provide the required minimum airspace to roof and/or framing members. After adding vent sections so that the assembly extends up through and is centered within the prepared opening, slide the flashing down over the assembly. On a sloped roof, insert the upper edge and sides of flashing under the roofing material using non-hardening, waterproof mastic around the perimeter of the bottom side and nail to the roof along the upper edge. Do not nail the lower edge, but be sure to include mastic along its bottom edge. On a flat roof, use mastic or caulking around the perimeter of the bottom side, set on roof and nail or screw at the corners. Apply mastic over the heads of the fasteners and an additional bead around the edge.

STORM COLLAR (VP-SC)

The storm collar is used at the top of each flashing to assist in shedding water from the assembly. **To Install:** Prior to installing the cap and after installing the flashing, install the storm collar by sliding it down over the upper vent section until it rests directly upon the flashing. Apply non-hardening waterproof mastic along the line where the storm collar meets the vent.

VERTICAL TERMINATION CAP (VP-VC)

The VP-VC is intended for use in all installations in which the vent terminates in a vertical orientation. The cap provides necessary protection of the vent system from rain and other elements.

To Install: Simply push the cap down onto the top section of vent until the spring clips engage. No additional attachment is required.

TERMINATION HEIGHT ABOVE ROOF - The termination of Model VP should be located a sufficient distance from the roof so that the discharge opening is at least two (2) feet above the roof surface, or nearby structure.

HORIZONTAL TERMINATION CAP (VP-HC)

The horizontal termination cap is designed specifically for use on installations in which the vent terminates in a horizontal orientation on the outside of a structure. See Fig. 4 and the section which discusses this type installation.

To Install: Slide the cap onto the (minimum 6") section of vent extending out from the wall until the tabs engage. Orient the cap so that the shielded sides of the assembly are on top and bottom while the two outlet openings are facing the sides. NOTE - In order for the cap to provide the intended protection and vent the products of combustion properly, the cap must be installed in the above described orientation. Once installed as intended, carefully drill 3/32" holes in the left and right side of the cap's collar and through (only) the outer wall of the vent section. Drive a 1/4" long sheet metal screw in each hole to prevent the cap from being removed or rotated unintentionally.

The above part descriptions and installation instructions should be referenced as you plan and install your particular installation.

EXIT CAP (VP-EC)

As an alternate to the Horizontal Termination, an Exit Cone Cap is available. This cap is designed to direct flue gases perpendicular to the wall and to increase their velocity, projecting them further away from the building.

Note: When using the Exit Cone Cap, make sure it will be installed so that the hot flue gases do not overheat any of the surrounding area or pose any burn hazard to humans.

To Install: Slide the Exit Cone Cap onto the section of vent extending out from the wall until the lances on the cap engage within the groove on the end of the pipe.

15. PAINTING

To prolong the life and appearance of the outer casing and other parts of the Selkirk Model VP Vent System located outdoors, use proper painting procedure at time of installation. Remove oil and dirt with a solvent. Paint first with a good quality zinc primer or other primer recommended for use on galvanized steel. Next apply an appropriate finish coat. Similar considerations apply for painting of internal components, for aesthetic purposes.

Ordinary house paints applied directly to outer casing may not adhere well and do not prevent under film corrosion which leads to paint loosening and peeling. Be sure to use a good primer undercoat and an appropriate finish coat.

16. MAINTENANCE REQUIREMENTS

Refer to the appliance manufacturer's maintenance instructions for recommendations relative to required maintenance of your appliance.

-Model VP vent system requires periodic inspection and cleaning with an appropriately sized brush which will not scratch the inside surface of the flue. DO NOT USE chemical cleaners to clean your venting system.

-Frequency of necessary vent system cleaning will vary with the appliance, vent system configuration and climate. Certain pellet burning appliances or pelletized fuels may give off more fine dust than others.

-In any case it is recommended that the complete assembly be inspected and cleaned (if any buildup has occurred) at the beginning of each heating season and at least monthly thereafter.

-TO INSPECT AND CLEAN . . . Remove the termination cap by removing any screws, then rotating and pulling until it disengages. Remove the tee cap(s) by removing the stop screw and pulling the cap off. Inspect system. If necessary clean by running a brush through the system several times in each direction. NOTE - Be sure that tee and termination caps are reinstalled and secured when Inspection/ Cleaning is completed and before the system is put back in use.

-IN CASE OF FIRE . . . If a fire occurred within the vent system, de-energize the appliance, close all draft controls, evacuate the premises and call the Fire Department. Do not use the appliance or vent system until they have been inspected by a qualified individual and declared suitable for further use.

MODEL VP SYSTEM PARTS

PART	DESCRIPTION
VP-60	5' Length
VP-60B	5' Length - Black
VP-36	3' Length
VP-36B	3' Length - Black
VP-24	2' Length
VP-12	1' Length
VP-EZAJ12	1' Adjustable Length
VP-45EL	45Deg Elbow
VP-90EL	90Deg Elbow
VP-AF	Adjustable Roof Flashing
VP-CS	Ceiling Support/ Firestop Spacer
VP-CCS	Cathedral Ceiling Support
VP-TD	Double Tee w/Tee Cap
VP-TS	Tee w/Tee Cap
VP-SC	Storm Collar
VP-TF	Tall Cone Roof Flashing
VP-WB	Wall Bracket/ Support
VP-WS	Tee Support
VP-HC	Horizontal Termination Cap
VP-VC	Vertical Termination Cap
VP-WT	Wall Thimble
VP-WTT	Thick Wall Thimble
VP-ES	Exterior Shield
VP-PC	Pipe Connector
VP-PCB	Pipe Connector - Black
VP-A6	MCS Adapter - 6"
VP-A8	MCS Adapter - 8"
3VP-I4	Increaser - 3" to 4"
VP-TP	Trim Plate - Black
VP-EC	Exit Cap

INSTALLATION INFORMATION

Leave with homeowner. Homeowner: Keep in a safe place for future reference.

PRODUCT INFO

VENT MODEL : **VP**
FLUE SIZE _____

TOTAL HEIGHT _____

INSIDE INSTALLATION OUTSIDE INSTALLATION

CONNECTED TO (type of appliance):

WOOD PELLET APPLIANCE
WOOD PELLET BOILER
WOOD PELLET INSERT
WOOD PELLET FURNACE
OTHER (specify) _____

LOCATION OF APPLIANCE:

BASEMENT
MAIN FLOOR
OTHER (specify) _____

INSTALLATION DATE: _____

DEALER INFO

DEALER NAME: _____

Address: _____

City: _____

Province/State: _____

TECHNICIAN INFO

TECHNICIAN NAME: _____

Address: _____

City: _____

Province/State: _____

Selkirk Corporation
5030 Corporate Exchange Blvd.
Grand Rapids, MI 49512
Toll Free 1.800.443.6341
info@selkirkcorp.com



www.selkirkcorp.com

Selkirk Canada
P. O. Box 526, Depot 1,
Hamilton, On, L8L 7X6
Toll Free 1.888.SELKIRK (735.5475)
cscanada@selkirkcorp.com