

# Installation Instruction Supplement - Adapting Selkirk Chimney to an Existing Masonry Chimney "Bond Beam" Type Attachment Method

**General:**

This Supplement covers use of the Selkirk Chimney System (SCS) Anchor Plate (AP) for adaptation of Selkirk chimney to an existing masonry chimney using the concrete "Bond Beam" attachment method.

Before installing per this method, reference the Selkirk Chimney General Instructions (Sheet GS) and Anchor Plate Instructions (Sheet S4) for additional information.

The masonry chimney should be leveled at the appropriate height and a concrete Bond Beam should be properly constructed by a qualified person / contractor as shown in Fig. 1.

Unless otherwise specified by local code, the Bond Beam should be a minimum of 6" thick and provide an uninterrupted, smooth transition from the existing masonry flue to the inlet of the MCS Anchor Plate.

The SCS chimney should be sized such that it's inner cross-sectional area is

approximately equivalent to that of the existing masonry flue. Reference Selkirk Sizing Handbook and the SCS "Guide to General Instructions" (Sheet P) packaged with each chimney length for additional sizing information.

Although not mandatory, it is recommended to apply a 3/4" bed of mortar on top of the Bond Beam and ultimately attach the SCS anchor plate to the bed of mortar with the use of four 1/4" diameter, 2" long anchor bolts. (See Fig. 1) Regardless, the top surface (whether Bond Beam or mortar) should be level.

If an enclosure is to be constructed around the SCS chimney, be sure to incorporate the proper 2" airspace clearance-to-combustibles.

Local codes may permit or require minor variations in the Bond Beam construction. Contact Local Code Authorities for specific requirements in your area.

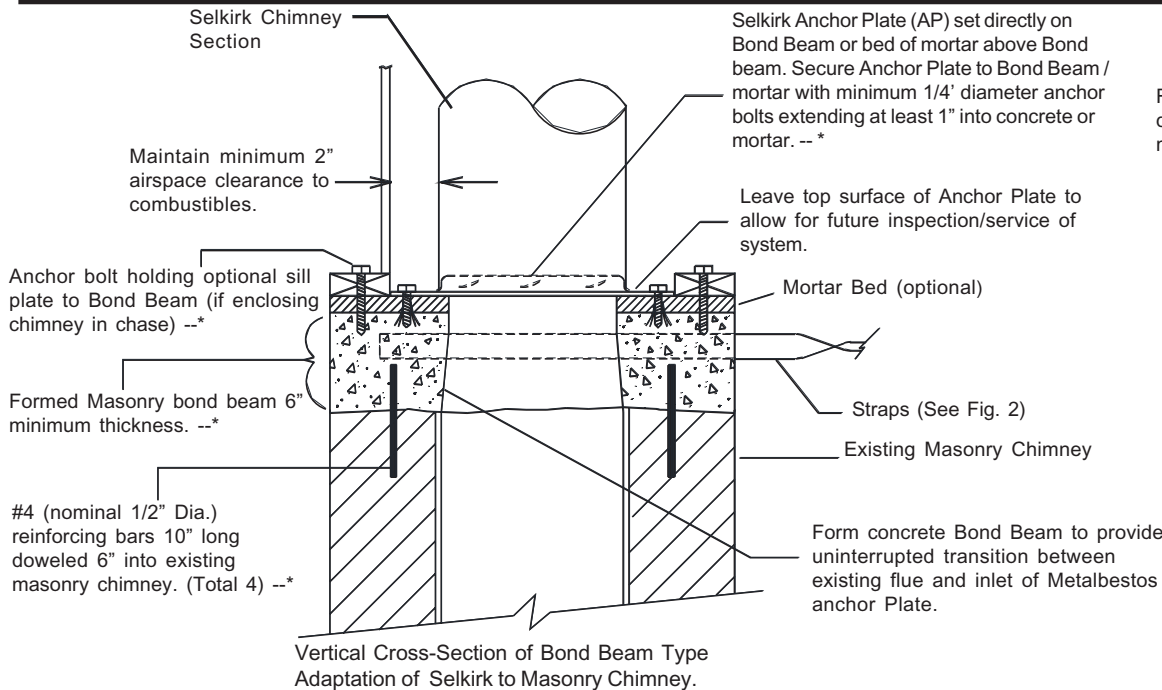
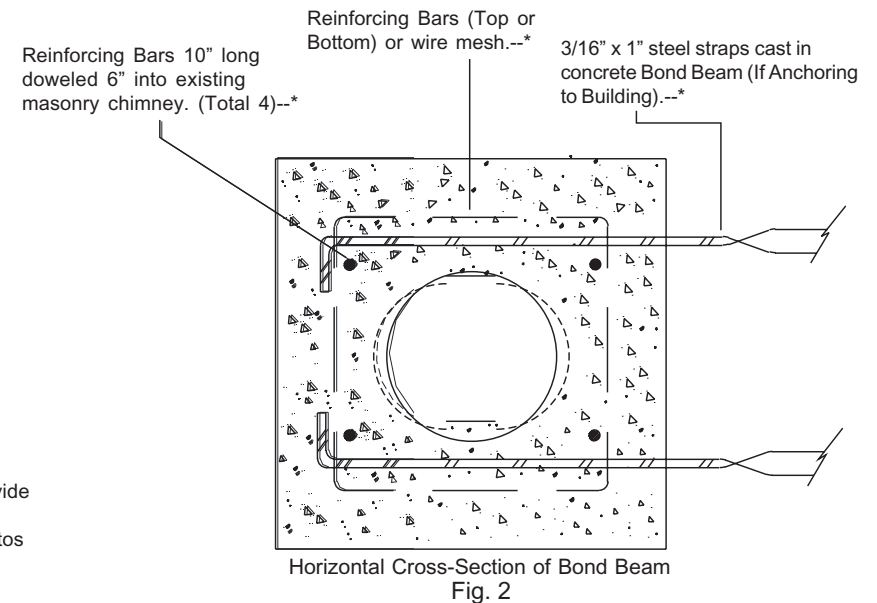

Fig. 1

\* = Note: All Dimensions, Sizes and Material Specifications Relating to Bond Beam Construction are Subject to Modification Per Local Code Requirements.



Horizontal Cross-Section of Bond Beam  
Fig. 2

**⚠ WARNING**

Failure to follow the instructions could cause **FIRE, CARBON MONOXIDE POISONING, OR DEATH.** If you are unsure of installation requirements, call the Phone Number listed on the instructions or sizing handbook or visit [www.selkirkcorp.com](http://www.selkirkcorp.com).