

# Model G

## Single Wall Venting Systems



Model G is a single wall negative, neutral, or positive pressure prefabricated venting system intended for use in a variety of applications.



### APPLICATIONS

- *Laboratory Fume Venting*
- *Masonry Chimney Liner*
- *Chutes*
- *Grease Duct*
- *Dryer Vents*
- *Dishwasher Exhaust*

## GENERAL USAGE

COMMON INSTALLATION TYPES..... 3

## MODEL G

JOINT ASSEMBLY PARTS..... 4

SINGLE WALL PIPE..... 6

ADJUSTABLE SINGLE WALL PIPE..... 6

SINGLE WALL FITTINGS..... 7

CONNECTION ACCESSORIES..... 10

JOINT ASSEMBLY ACCESSORIES..... 10

SUPPORT/GUIDE ACCESSORIES..... 11

ROOF PENETRATIONS..... 12

TERMINATIONS..... 12

### MODEL G

Model G is a single wall negative, neutral, or positive pressure capable, stainless steel pre-fabricated piping system for use in many applications including: grease duct, fume venting, chimney liner, chutes, particle conveying, etc. Model G is UL Listed for grease duct applications. Factory design assistance and submittals are available for Model G like all other Selkirk Commercial/Industrial products.

### CORROSION RESISTANT

Standard Model G is available in type 304 stainless steel in 0.035" minimum thickness for sizes 6" through 36" I.D. and 0.048" minimum thickness for sizes 42" through 48" I.D. The type 316 alloy may also be specified for its corrosion resistance to chemicals. Type 304 or 316 stainless steel is available in 0.048" minimum thickness in all sizes.

### COMPONENT PARTS

Model G component parts are available in standard sizes 5" through 48", measured by diameter of the pipe. Parts are identified by individual part names and numbers. Each part name/number carries a diameter prefix size, the letter "G" designating Model G, followed by its individual letter code, material type and length if required. See legend below for part number.

### JOINT ASSEMBLY

For all Model G pipe and fittings, the flange-to-flange inner pipe joints are identical for each pipe I.D. Assembly of a typical joint is handled quickly and easily with regular maintenance crews and requires only standard hand tools and a Selkirk® specified sealant.



### METHODS OF SUPPORT

For structural support, use the Model PS Plate Support Assembly. Special dimensioned half rings and full rings are also available for guided support.

## MODEL G SAMPLE SPECIFICATION FOR SINGLE WALL EXHAUST

The factory-built system shall be designed and installed to be liquid tight and thus prevent leakage of the exhaust into the building. The system shall be designed to compensate for all thermal expansion.

The single wall exhaust shall be of type 304 (or 316) stainless steel. Minimum steel thickness shall be 0.035" (or 0.048").

Pipe joints shall be sealed by use of factory supplied Vee Bands and sealant.

The entire system from outlet to the termination; including accessories, except as noted, shall be from the manufacturer.

The diameter for the exhaust shall be verified by the manufacturers' computations. The computation shall be technically sound, shall follow ASHRAE calculation methods, and incorporate the specific flow characteristics of the pipe.

Specification requirements shall be met by using Selkirk® Model G or equivalent as approved by the responsible engineer. Equivalent bids shall specify manufacturer, model number, and other pertinent identification; and attest that the alternate is in compliance with all specification requirements.

Part Number Description:

**6G304-VL30**

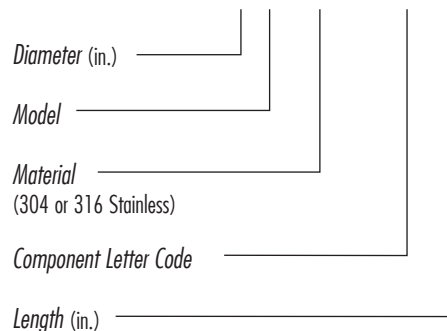

# COMMON INSTALLATION TYPES

## MODEL G FUME VENTING

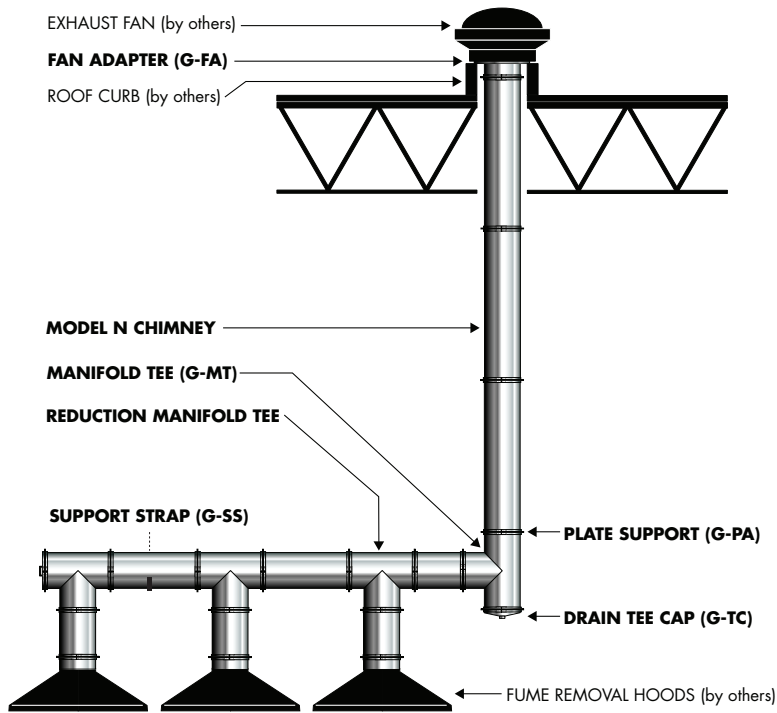

## MODEL G CHIMNEY LINER

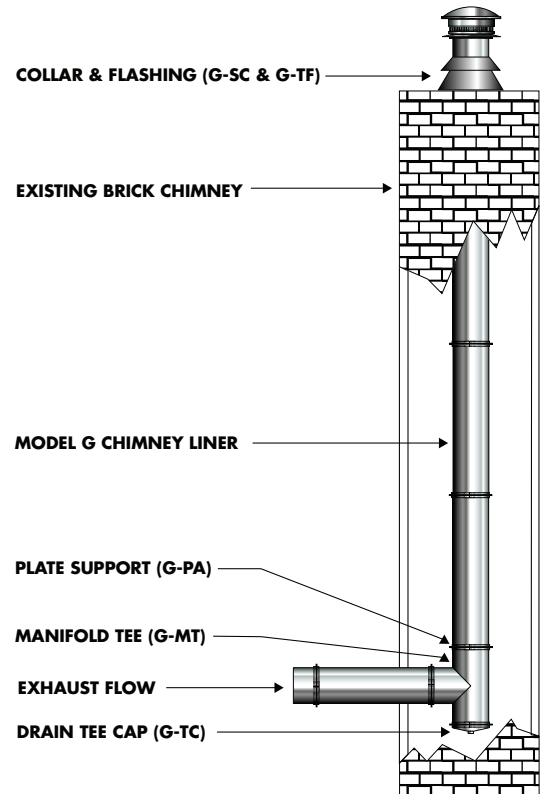

## MODEL G GREASE DUCT

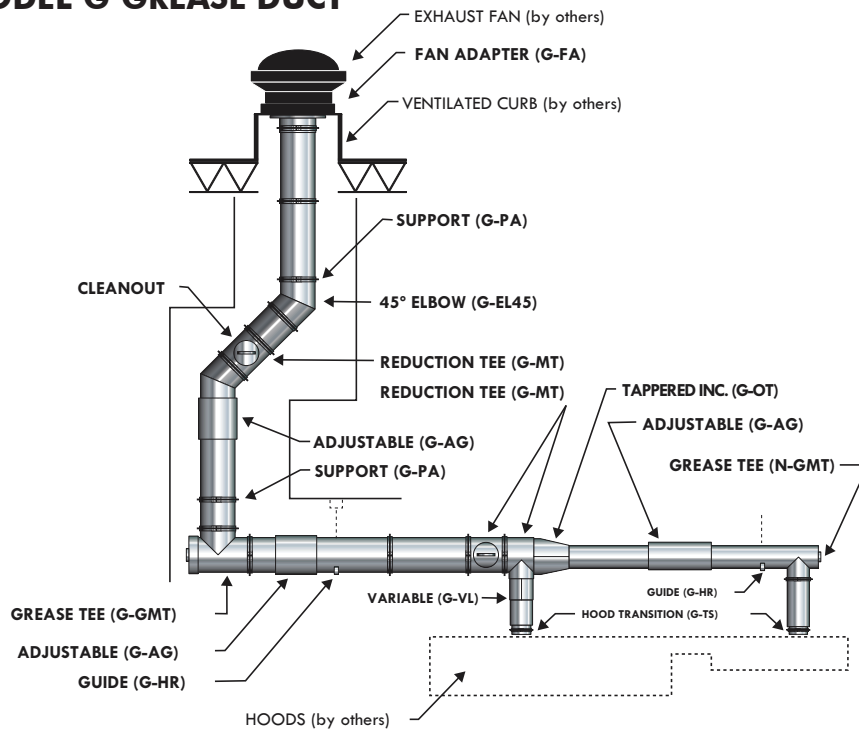

## Overlapping Vee Band

Code:  
VB

Vee Band for connecting inner 1/2" rolled flanges. Capable of holding 60" w.c. of pressure when properly installed.



Materials Available:

**All Stainless Construction**

Notes:

1. VB's are a one or two-piece design. Included with pipe sections.

## Alignment Sleeve

Code:  
AS

Used in centering adjacent components in horizontal and vertical orientations to facilitate installation.



Materials Available:

**All Stainless Construction**

Notes:

1. AS included with pipe sections.

## Low Temperature Sealant

Code: P600

## High Temperature Sealant

Code: P2000

## High Efficiency Condensing Sealant

Code: SGV550

Depending upon application, appropriate sealants are applied to the VB before connecting two Inner Pipes at installation.

As designated, P600 Sealant is for 600° F. maximum flue gas temperatures, and also for exterior weathering of pipe, while P2000 is capable for flue gases up to 2,000° F (Not to be used externally); SGV550 is for 550° F maximum flue gas temperature for all SGV applications.

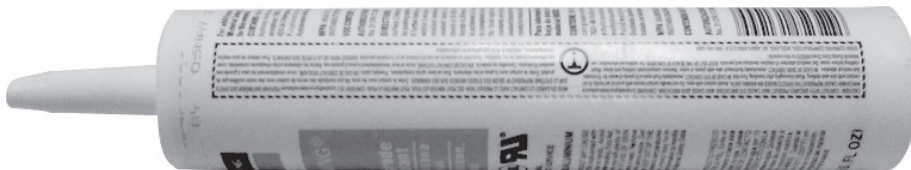

### Sealant Coverage

*Expected Number of Joints Sealed Per Tube*

Inner Dia. (inches)	P600
	P2000 SGV550
5/6	5
8/10	5
12	4
14/16	4
18/20	3
22/24	3
26/28	2
30/32	2
36	1
42/48	.5

## Joint Assembly

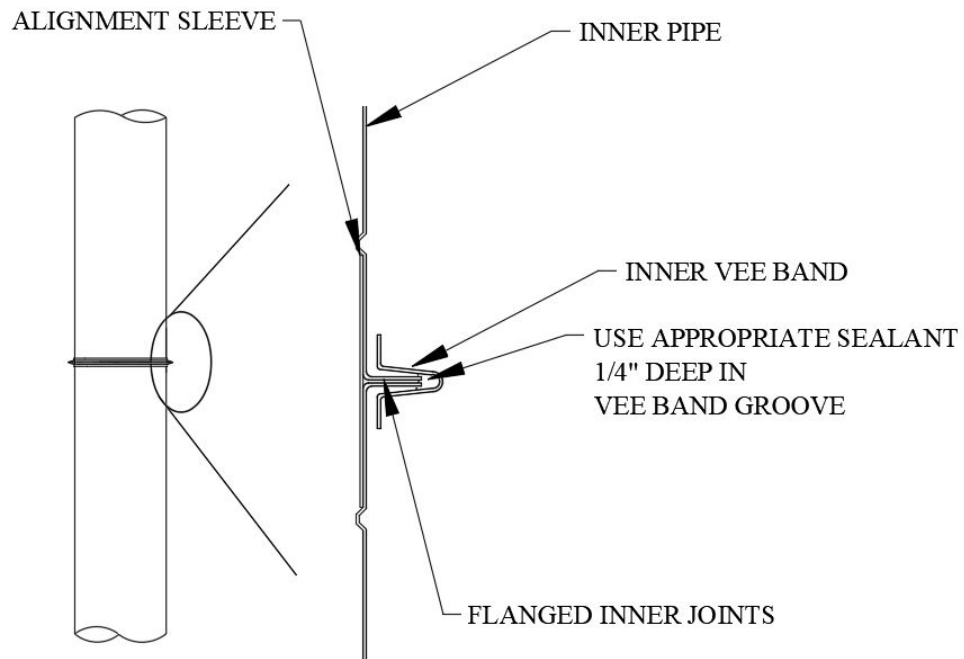

# SINGLE WALL PIPE

## STANDARD LENGTH CODE: 18, 30, 42 & 59

A variety of straight pipe lengths are available with Model G. Special lengths are also available and can be made with a minimum dimension of 6" diameter. Seal pipe joints with P-600 Silicone sealant for flue gas temperatures up to 600°F. For temperatures above 600°F use P-2000E high temperature sealant.

- 18" and 30" lengths** available in 5"-48" diameters
- 42" lengths** available in 5"-42" diameters
- 59.13" lengths** available in 6"-26" diameters

Materials Available:

304	316
-----	-----

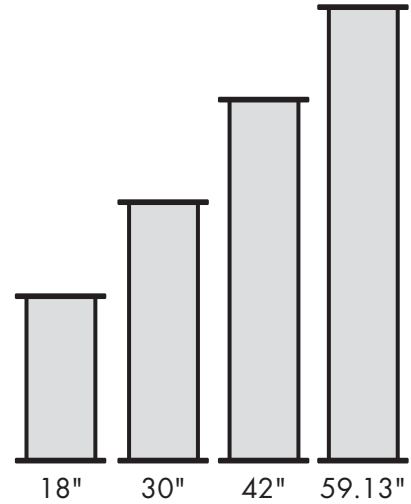

# ADJUSTABLE SINGLE WALL PIPE

## ADJUSTABLE LENGTH CODE: AG18 & AG30

**USE:** The G-AG18/30 is used for thermal expansion compensation in any pipe line running between two fixed points.

**NOTE:** For diameters over 26", part G-AG30 must be used.

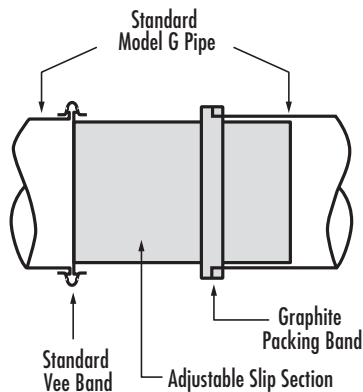

- 18" Adjustable length** available in 5"-26" diameters
- 30" Adjustable length** available in 5"-48" diameters

Flow Resistance Factor is the same as standard pipe.

Materials Available:

304	316
-----	-----

**NOTE:**

1. Minimum installed length is 4".
2. AG 18 not available for 28" diameter and above.
3. Maximum installed space is when the inner slip section protrudes at least 1/2 pipe diameter into the adjacent pipe.
4. Flow Resistance Factor (K) is the same as insulated pipe lengths.

## VARIABLE LENGTH CODE: AG18 & AG30

**USE:** Part G-VL18 is used as length to fill odd dimensions of 4" to 14". Part G-VL30 is used to fill odd dimensions of 4" to 26".

**NOTE:** G-VL does not allow for thermal expansion.

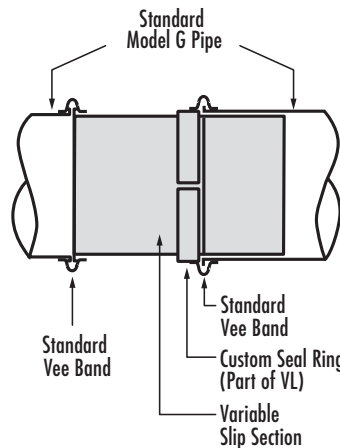

- 18" Adjustable length** available in 5"-48" diameters

Flow Resistance Factor is the same as standard pipe.

Materials Available:

304	316
-----	-----

# SINGLE WALL FITTINGS

## 90° TEE CODE: MT

**USE:** To join horizontal and vertical sections of pipe. The G-MT provides for connection for a drain or inspection fitting.

**NOTE:** A reduction Manifold Tee is offered.

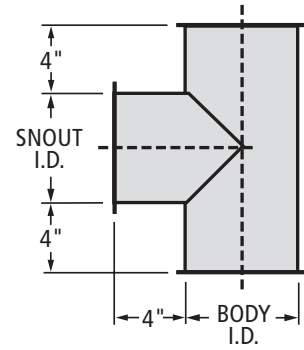

$K = 1.25$  Flow Resistance Factor

## 45° LATERAL TEE CODE: JL

**USE:** The G-JL is used to join horizontal and vertical sections of pipe at a 45 degree angle.

**NOTE:** A reduction G-JL is offered. A, B, and C dimensions would remain the same.

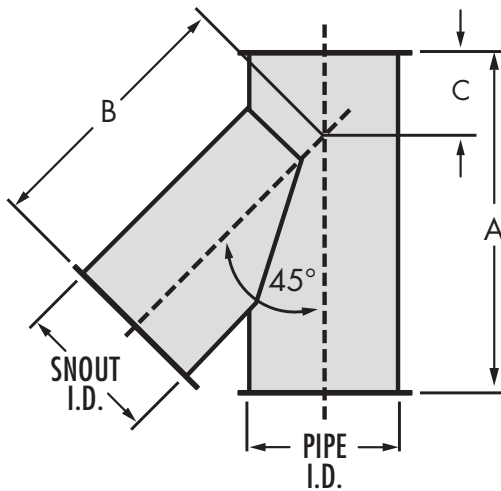

Part No.	Pipe Size I.D.	Dim. A	Dim. B	Dim. C
5G-JL	5"	19 <sup>1</sup> / <sub>2</sub>	13 <sup>3</sup> / <sub>4</sub>	5 <sup>3</sup> / <sub>4</sub>
6G-JL	6"	19 <sup>1</sup> / <sub>2</sub>	13 <sup>3</sup> / <sub>4</sub>	5 <sup>3</sup> / <sub>4</sub>
8G-JL	8"	22 <sup>7</sup> / <sub>8</sub>	16 <sup>5</sup> / <sub>8</sub>	6 <sup>1</sup> / <sub>4</sub>
10G-JL	10"	24 <sup>1</sup> / <sub>16</sub>	19	5 <sup>1</sup> / <sub>16</sub>
12G-JL	12"	26 <sup>15</sup> / <sub>16</sub>	21 <sup>7</sup> / <sub>16</sub>	5 <sup>1</sup> / <sub>2</sub>
14G-JL	14"	29 <sup>3</sup> / <sub>4</sub>	23 <sup>7</sup> / <sub>8</sub>	5 <sup>7</sup> / <sub>8</sub>
16G-JL	16"	32 <sup>9</sup> / <sub>16</sub>	26 <sup>1</sup> / <sub>4</sub>	6 <sup>5</sup> / <sub>16</sub>
18G-JL	18"	35 <sup>3</sup> / <sub>8</sub>	28 <sup>3</sup> / <sub>4</sub>	6 <sup>3</sup> / <sub>4</sub>
20G-JL	20"	38 <sup>3</sup> / <sub>16</sub>	31 <sup>1</sup> / <sub>16</sub>	7 <sup>1</sup> / <sub>8</sub>
22G-JL	22"	43 <sup>7</sup> / <sub>8</sub>	35 <sup>7</sup> / <sub>8</sub>	8
24G-JL	24"	43 <sup>7</sup> / <sub>8</sub>	35 <sup>7</sup> / <sub>8</sub>	8
26G-JL	26"	49 <sup>9</sup> / <sub>16</sub>	40 <sup>3</sup> / <sub>4</sub>	8 <sup>13</sup> / <sub>16</sub>
28G-JL	28"	49 <sup>9</sup> / <sub>16</sub>	40 <sup>3</sup> / <sub>4</sub>	8 <sup>13</sup> / <sub>16</sub>
30G-JL	30"	55 <sup>3</sup> / <sub>16</sub>	45 <sup>9</sup> / <sub>16</sub>	9 <sup>5</sup> / <sub>8</sub>
32G-JL	32"	55 <sup>3</sup> / <sub>16</sub>	45 <sup>9</sup> / <sub>16</sub>	9 <sup>5</sup> / <sub>8</sub>
36G-JL	36"	60 <sup>13</sup> / <sub>16</sub>	50 <sup>3</sup> / <sub>8</sub>	10 <sup>7</sup> / <sub>16</sub>
42G-JL	42"	69 <sup>15</sup> / <sub>16</sub>	58 <sup>1</sup> / <sub>4</sub>	11 <sup>3</sup> / <sub>4</sub>
48G-JL	48"	79 <sup>3</sup> / <sub>16</sub>	66 <sup>1</sup> / <sub>8</sub>	13

$K = 0.4$  Flow Resistance Factor

## 90° WYE CODE: JY

**USE:** The G-JY is intended for low pressure drop joining of two appliances.

**NOTE:** All openings are the same size diameter.

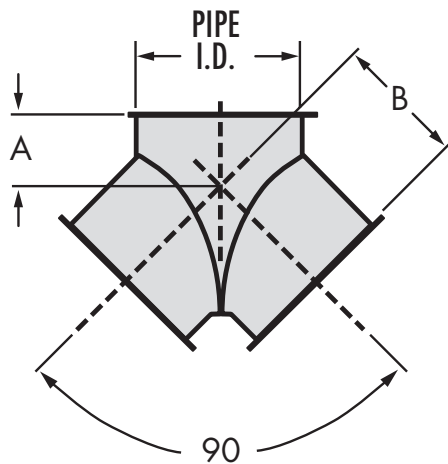

Part No.	Pipe Size I.D.	Dim. A	Dim. B
5G-JY	5"	4 <sup>5</sup> / <sub>8</sub>	9
6G-JY	6"	4 <sup>5</sup> / <sub>8</sub>	9
8G-JY	8"	5 <sup>1</sup> / <sub>16</sub>	10
10G-JY	10"	5	11
12G-JY	12"	5 <sup>1</sup> / <sub>2</sub>	12
14G-JY	14"	5 <sup>7</sup> / <sub>8</sub>	13
16G-JY	16"	6 <sup>3</sup> / <sub>8</sub>	14
18G-JY	18"	6 <sup>5</sup> / <sub>8</sub>	15
20G-JY	20"	7 <sup>1</sup> / <sub>8</sub>	17
22G-JY	22"	8	19
24G-JY	24"	8	19
26G-JY	26"	8 <sup>3</sup> / <sub>4</sub>	22
28G-JY	28"	8 <sup>3</sup> / <sub>4</sub>	22
30G-JY	30"	9 <sup>5</sup> / <sub>8</sub>	24
32G-JY	32"	9 <sup>5</sup> / <sub>8</sub>	24
36G-JY	36"	10 <sup>1</sup> / <sub>2</sub>	27
42G-JY	42"	11 <sup>3</sup> / <sub>4</sub>	31
48G-JY	48"	13	34

$K = 0.6$  Flow Resistance Factor

# SINGLE WALL FITTINGS

## 30° FIXED ELBOW CODE: EL30

**USE:** Designed to change the direction of a breeching 30 degrees in a vertical or horizontal run.

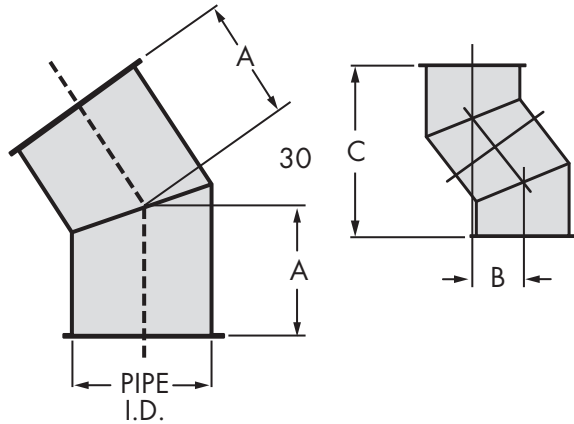

Materials Available:

304	316
-----	-----

Part No.	Pipe Size I.D.	Dim. A	Dim. B	Dim. C
5G-EL30	5"	6 <sup>1</sup> / <sub>8</sub>	6 <sup>1</sup> / <sub>8</sub>	22 <sup>3</sup> / <sub>8</sub>
6G-EL30	6"	6 <sup>1</sup> / <sub>8</sub>	6 <sup>1</sup> / <sub>8</sub>	22 <sup>7</sup> / <sub>8</sub>
8G-EL30	8"	6 <sup>3</sup> / <sub>8</sub>	6 <sup>3</sup> / <sub>8</sub>	22 <sup>7</sup> / <sub>8</sub>
10G-EL30	10"	6 <sup>11</sup> / <sub>16</sub>	6 <sup>11</sup> / <sub>16</sub>	24 <sup>7</sup> / <sub>8</sub>
12G-EL30	12"	7 <sup>5</sup> / <sub>16</sub>	7 <sup>5</sup> / <sub>16</sub>	27 <sup>1</sup> / <sub>4</sub>
14G-EL30	14"	7 <sup>7</sup> / <sub>8</sub>	7 <sup>7</sup> / <sub>8</sub>	29 <sup>5</sup> / <sub>8</sub>
16G-EL30	16"	8 <sup>1</sup> / <sub>4</sub>	8 <sup>1</sup> / <sub>4</sub>	30 <sup>3</sup> / <sub>8</sub>
18G-EL30	18"	8 <sup>5</sup> / <sub>8</sub>	8 <sup>5</sup> / <sub>8</sub>	31 <sup>5</sup> / <sub>8</sub>
20G-EL30	20"	9 <sup>1</sup> / <sub>8</sub>	9 <sup>1</sup> / <sub>8</sub>	34 <sup>1</sup> / <sub>8</sub>
22G-EL30	22"	9 <sup>3</sup> / <sub>8</sub>	9 <sup>3</sup> / <sub>8</sub>	35
24G-EL30	24"	10 <sup>1</sup> / <sub>16</sub>	10 <sup>1</sup> / <sub>16</sub>	37 <sup>1</sup> / <sub>2</sub>
26G-EL30	26"	10 <sup>5</sup> / <sub>16</sub>	10 <sup>5</sup> / <sub>16</sub>	38 <sup>1</sup> / <sub>2</sub>
28G-EL30	28"	11	11	40 <sup>7</sup> / <sub>8</sub>
30G-EL30	30"	11 <sup>1</sup> / <sub>4</sub>	11 <sup>1</sup> / <sub>4</sub>	41 <sup>7</sup> / <sub>8</sub>
32G-EL30	32"	11 <sup>7</sup> / <sub>8</sub>	11 <sup>7</sup> / <sub>8</sub>	44 <sup>3</sup> / <sub>8</sub>
36G-EL30	36"	12 <sup>7</sup> / <sub>8</sub>	12 <sup>3</sup> / <sub>4</sub>	47 <sup>3</sup> / <sub>4</sub>
42G-EL30	42"	14	14	52 <sup>1</sup> / <sub>2</sub>
48G-EL30	48"	14 <sup>3</sup> / <sub>16</sub>	14 <sup>3</sup> / <sub>16</sub>	56 <sup>7</sup> / <sub>16</sub>

*K = 0.12 Flow Resistance Factor*

## 45° FIXED ELBOW CODE: EL45

**USE:** The G-EL45 is used to join horizontal and vertical sections of pipe at a 45 degree angle.

**NOTE:** A reduction G-JL is offered. A, B, and C dimensions would remain the same.

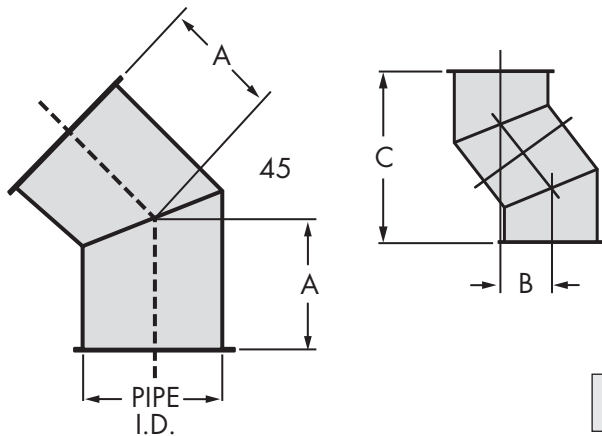

Materials Available:

304	316
-----	-----

Part No.	Pipe Size I.D.	Dim. A	Dim. B	Dim. C
5G-EL45	5"	8 <sup>1</sup> / <sub>2</sub>	12	29
6G-EL45	6"	8 <sup>1</sup> / <sub>2</sub>	12	29
8G-EL45	8"	8 <sup>15</sup> / <sub>16</sub>	12 <sup>5</sup> / <sub>8</sub>	30 <sup>7</sup> / <sub>8</sub>
10G-EL45	10"	9 <sup>5</sup> / <sub>16</sub>	13 <sup>3</sup> / <sub>16</sub>	31 <sup>7</sup> / <sub>8</sub>
12G-EL45	12"	10 <sup>1</sup> / <sub>4</sub>	14 <sup>1</sup> / <sub>2</sub>	35
14G-EL45	14"	10 <sup>11</sup> / <sub>16</sub>	15 <sup>1</sup> / <sub>8</sub>	36 <sup>1</sup> / <sub>2</sub>
16G-EL45	16"	11 <sup>5</sup> / <sub>8</sub>	16 <sup>7</sup> / <sub>16</sub>	39 <sup>5</sup> / <sub>8</sub>
18G-EL45	18"	12 <sup>1</sup> / <sub>8</sub>	17 <sup>1</sup> / <sub>16</sub>	41 <sup>1</sup> / <sub>8</sub>
20G-EL45	20"	13	18 <sup>3</sup> / <sub>8</sub>	44 <sup>1</sup> / <sub>4</sub>
22G-EL45	22"	13 <sup>5</sup> / <sub>16</sub>	18 <sup>13</sup> / <sub>16</sub>	45 <sup>1</sup> / <sub>2</sub>
24G-EL45	24"	14 <sup>5</sup> / <sub>16</sub>	20 <sup>1</sup> / <sub>4</sub>	48 <sup>1</sup> / <sub>8</sub>
26G-EL45	26"	14 <sup>7</sup> / <sub>8</sub>	21 <sup>1</sup> / <sub>16</sub>	50 <sup>7</sup> / <sub>8</sub>
28G-EL45	28"	15 <sup>11</sup> / <sub>16</sub>	22 <sup>3</sup> / <sub>16</sub>	53 <sup>1</sup> / <sub>2</sub>
30G-EL45	30"	16 <sup>1</sup> / <sub>4</sub>	22 <sup>15</sup> / <sub>16</sub>	53 <sup>3</sup> / <sub>8</sub>
32G-EL45	32"	17	24	58
36G-EL45	36"	18 <sup>3</sup> / <sub>8</sub>	25 <sup>15</sup> / <sub>16</sub>	62 <sup>5</sup> / <sub>8</sub>
42G-EL45	42"	19 <sup>11</sup> / <sub>16</sub>	27 <sup>7</sup> / <sub>8</sub>	67
48G-EL45	48"	21 <sup>7</sup> / <sub>16</sub>	30 <sup>5</sup> / <sub>16</sub>	74 <sup>7</sup> / <sub>8</sub>

*K = 0.15 Flow Resistance Factor*

## 90° FIXED ELBOW CODE: EL90

**USE:** The G-EL90 is used to join horizontal and vertical sections of pipe at a 90 degree angle.

**NOTE:** All openings are the same size diameter.

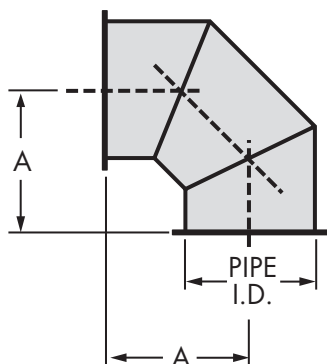

Materials Available:

304	316
-----	-----

Part No.	Pipe Size I.D.	Dim. A
5G-EL90	5"	11 <sup>1</sup> / <sub>2</sub>
6G-EL90	6"	11 <sup>1</sup> / <sub>2</sub>
8G-EL90	8"	12 <sup>1</sup> / <sub>2</sub>
10G-EL90	10"	13 <sup>1</sup> / <sub>2</sub>
12G-EL90	12"	14 <sup>1</sup> / <sub>2</sub>
14G-EL90	14"	15 <sup>1</sup> / <sub>2</sub>
16G-EL90	16"	16 <sup>1</sup> / <sub>2</sub>
18G-EL90	18"	17 <sup>1</sup> / <sub>2</sub>
20G-EL90	20"	18 <sup>1</sup> / <sub>2</sub>
22G-EL90	22"	19 <sup>1</sup> / <sub>2</sub>
24G-EL90	24"	20 <sup>1</sup> / <sub>2</sub>
26G-EL90	26"	21 <sup>1</sup> / <sub>2</sub>
28G-EL90	28"	22 <sup>1</sup> / <sub>2</sub>
30G-EL90	30"	23 <sup>1</sup> / <sub>2</sub>
32G-EL90	32"	24 <sup>1</sup> / <sub>2</sub>
36G-EL90	36"	26 <sup>1</sup> / <sub>2</sub>
42G-EL90	42"	29 <sup>1</sup> / <sub>2</sub>
48G-EL90	48"	32 <sup>1</sup> / <sub>2</sub>

*K = 0.30 Flow Resistance Factor*



# SINGLE WALL FITTINGS

## 15° ELBOW

**USE:** Two-piece Elbow can establish many different degrees when combined with other standard Elbows.

CODE: **EL15**

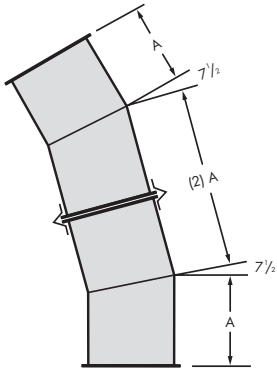

Part No.	A
5G-EL15	4 <sup>3</sup> / <sub>16</sub> "
6G-EL15	4 <sup>3</sup> / <sub>16</sub> "
8G-EL15	4 <sup>1</sup> / <sub>4</sub> "
10G-EL15	4 <sup>5</sup> / <sub>16</sub> "
12G-EL15	4 <sup>7</sup> / <sub>16</sub> "
14G-EL15	4 <sup>1</sup> / <sub>2</sub> "
16G-EL15	4 <sup>9</sup> / <sub>16</sub> "
18G-EL15	4 <sup>5</sup> / <sub>8</sub> "
20G-EL15	4 <sup>11</sup> / <sub>16</sub> "
22G-EL15	4 <sup>3</sup> / <sub>4</sub> "
24G-EL15	4 <sup>13</sup> / <sub>16</sub> "
26G-EL15	4 <sup>7</sup> / <sub>8</sub> "
28G-EL15	4 <sup>15</sup> / <sub>16</sub> "
30G-EL15	5"
32G-EL15	5 <sup>1</sup> / <sub>16</sub> "
36G-EL15	5 <sup>3</sup> / <sub>16</sub> "
42G-EL15	5 <sup>3</sup> / <sub>8</sub> "
48G-EL15	5 <sup>9</sup> / <sub>16</sub> "

K= 0.06 flow resistance factor

Materials Available:

304	316
-----	-----

## TAPERED INCREASER/REDUCER

**USE:** Used when a pipe diameter change is required.

CODE: **OT**

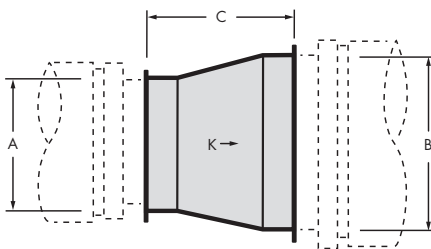

Dimensions:

A = Smaller Diameter

B = Larger Diameter

C = Installed Length = [(B-A) 2] + 2 (see Note 1 below)

Example:

Installed Length for 12P304-180T equals [(18-12)2] + 2 = 14 inches.

Notes:

1. Installed length shall not be greater than longest available straight pipe length.

2.  $K = N [1 - (A/B)^2]^2$

where N = 0.47 for one step OT

N = 0.53 for one step OT

Materials Available (shaded areas):

304/Alum	316/Alum	304/304	316/316
----------	----------	---------	---------

## CLEANOUT TEE CAP

**USE:** Used to close Tee opening at the base of a stack or the end of a horizontal run.

CODE: **TCN**

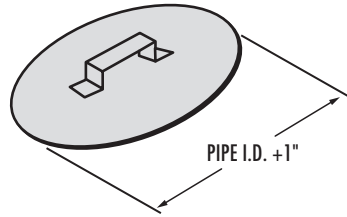

Part No. (pipe I.D.) G-TCN

Includes one OVB

Materials Available:

304	316
-----	-----

## DRAIN TEE CAP

**USE:** Provides a drain at the base of a vertical chimney when connected to the MT or JL

CODE: **TC**

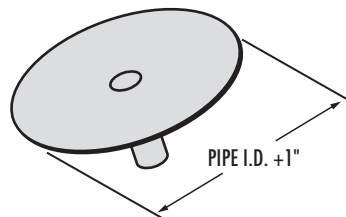

Part No. (pipe I.D.) G-TC

1" N.P.T. nipple on 5"-20" sizes

2" N.P.T. nipple on 22"-48" sizes

Includes one OVB

Materials Available:

304	316
-----	-----

## DRAIN SECTION DS

**USE:** Used with open stack terminations for draining off rain water from inside vertical or horizontal flue.

CODE: **DS**

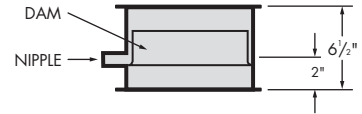

K= 0.25 flow resistance factor

Materials Available:

304	316
-----	-----

## STEP INCREASER/REDUCER

**USE:** Used when pipe diameter change is required in a small space.

CODE: **OS**

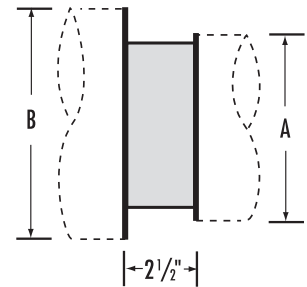

Dimensions:

A = Smaller Diameter

B = Larger Diameter

Notes:

1. This is a non-structural part; use only if OT will not fit within the allowable space.

2.  $K = N [1 - (A/B)^2]^2$

Materials Available:

304	316
-----	-----

# CONNECTION ACCESSORIES

## NOZZLE SECTION

**USE:** For use as fire suppression nozzle section or hot water/detergent maintenance section.

CODE: **FN**

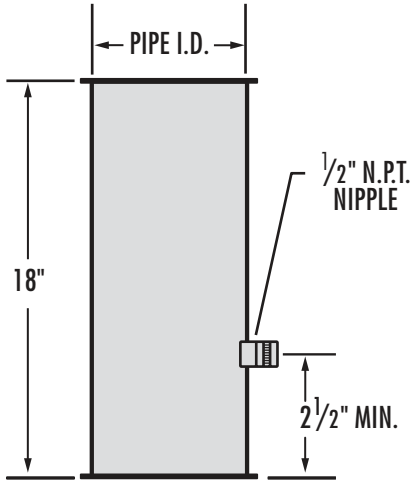

Materials Available:

304	316
-----	-----

## HOOD TRANSITION

**USE:** Securing Model G to flanged appliance outlets.

CODE: **TS**

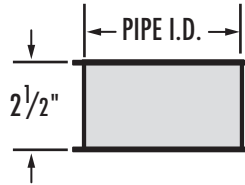

Materials Available:

304	316
-----	-----

## HOOD TRANSITION (Unflanged)

**USE:** Securing Model G to unflanged appliance outlets.

CODE: **TSU**

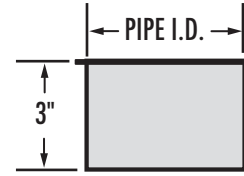

Materials Available:

304	316
-----	-----

## FAN ADAPTER FA

**USE:** Designed to secure Model G to fan inlet.

CODE: **FA**

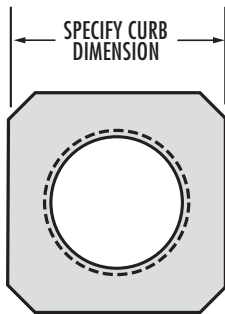
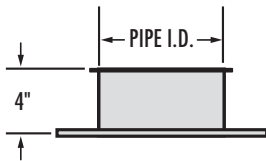

Materials Available:

304	316
-----	-----

# JOINT ASSEMBLY ACCESSORIES

## SEAL RING

**USE:** Used for non-welded attachment to appliances having an unflanged or collar outlet.

CODE: **SR**

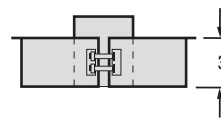

Materials Available:

304	316
-----	-----

# SUPPORT/GUIDE ACCESSORIES

## WALL GUIDE ASSEMBLY

**USE:** Same use as FR, but with factory-supplied bracing.

CODE: **WG**

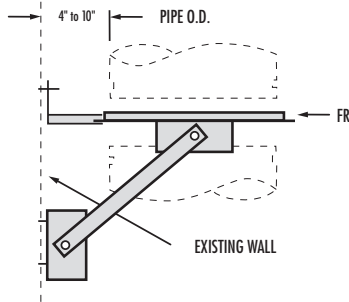

Ordered Part Included:

One FR, four struts, and six brackets.

Notes:

1. Assembly will maintain a 6" to 11" clearance between pipe O.D. and supporting structure.

Materials Available:

Electroplated or Galvanized Steel

## WALL SUPPORT ASSEMBLY

**USE:** "Limited" support assembly with factory-supplied bracing.

CODE: **WA**

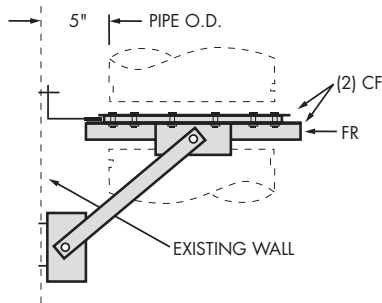

Ordered Part Includes:

One FR, two CFs, two HCBs, five brackets, two struts, and all hardware except connection at wall.

Notes:

1. Assembly will maintain a 5" clearance between pipe O.D. and supporting structure.

Materials Available:

Electroplated or Galvanized Steel

## PLATE SUPPORT ASSEMBLY

**USE:** Used for supporting the load of the stack and as a fixed point anchor near fittings.

CODE: **PA**

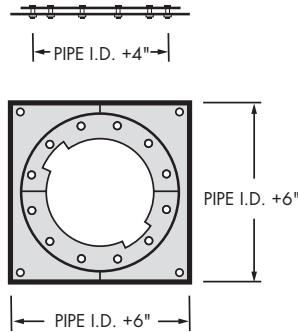

Ordered Part Includes:

Split (square) plate, one CF, two HCBs and hardware.

Plate Thickness:

0.188" for sizes 5" through 20" I.D. diameters

0.250" for sizes 22" through 36" I.D. diameters

0.375" for sizes 42" through 48" I.D. diameters

Notes:

1. Two 316 Stainless Steel HCBs should be ordered separately for stainless steel outer projects.
2. PA fabricated from 304 Stainless Steel is available upon request and is non-returnable. Allow extra manufacturing time.

Materials Available:

Electroplated or Galvanized Steel

## SUPPORT STRAP

**USE:** Available in 5" through 28"—G only. 0.188" Thick Rolled Steel.

CODE: **SS**

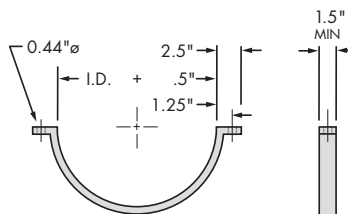

Materials Available:

Hot Rolled Steel

## ANGLE RINGS

**USE:** Used for guiding and/or supporting horizontal installations.

CODE: **HR & FR**

HR - Half Ring

FR - Full Ring

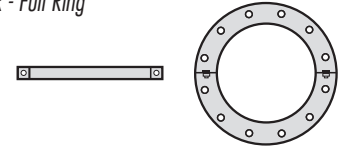

Part No.	Bolt Hole	I.D. of Ring	# of Holes	Size of Angle	Angle
5G-HR	9	5 <sup>1</sup> / <sub>8</sub>	6	(1)	45
6G-HR	10	6 <sup>1</sup> / <sub>8</sub>	6	(1)	45
8G-HR	12	8 <sup>1</sup> / <sub>8</sub>	6	(1)	45
10G-HR	14	10 <sup>1</sup> / <sub>8</sub>	6	(1)	45
12G-HR	16	12 <sup>1</sup> / <sub>8</sub>	6	(1)	45
14G-HR	18	14 <sup>1</sup> / <sub>8</sub>	6	(1)	45
16G-HR	20	16 <sup>1</sup> / <sub>8</sub>	6	(1)	45
18G-HR	22	18 <sup>1</sup> / <sub>8</sub>	6	(1)	45
20G-HR	24	20 <sup>1</sup> / <sub>8</sub>	6	(1)	45
22G-HR	26	22 <sup>1</sup> / <sub>8</sub>	10	(2)	22.5
24G-HR	28	24 <sup>1</sup> / <sub>8</sub>	10	(2)	22.5
26G-HR	30	26 <sup>1</sup> / <sub>8</sub>	10	(2)	22.5
28G-HR	32	28 <sup>1</sup> / <sub>8</sub>	10	(2)	22.5
30G-HR	34	30 <sup>1</sup> / <sub>8</sub>	10	(2)	22.5
32G-HR	36	32 <sup>1</sup> / <sub>8</sub>	10	(2)	22.5
36G-HR	40	36 <sup>1</sup> / <sub>8</sub>	10	(2)	22.5
42G-HR	46	42 <sup>1</sup> / <sub>8</sub>	10	(2)	22.5
48G-HR	52	48 <sup>1</sup> / <sub>8</sub>	10	(2)	22.5

(1) Size of Angle = 1<sup>1</sup>/<sub>2</sub> X 1<sup>1</sup>/<sub>2</sub> X 3<sup>3</sup>/<sub>8</sub>

(2) Size of Angle = 2 X 2 X 3<sup>3</sup>/<sub>16</sub>

Materials Available:

Electroplated or Galvanized Steel

# ROOF PENETRATIONS

## STORM COLLAR

**USE:** Used above the TF and PTF for complete weatherization above the roof.

CODE: **SC**

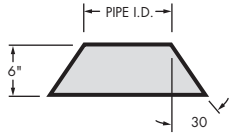

Notes:

1. Requires P600 sealant when installing.

Materials Available:

Aluminum or Galvanized Steel	304	316
------------------------------	-----	-----

## TALL FLASHING TF

**USE:** Used in conjunction with SC for weatherization at the roof.

CODE: **TF**

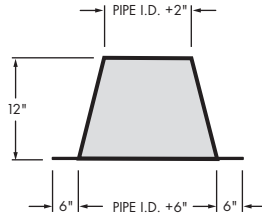

Notes:

1. Use limited to installations where complete roof penetration is non-combustible.

Materials Available:

Aluminum or Galvanized Steel	304	316
------------------------------	-----	-----

## PITCHED TALL FLASHING PTF

**USE:** Same function as TF, except for use on a pitched roof.

CODE: **PTF**

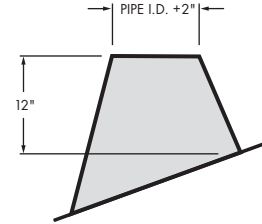

Notes:

1. Part is non-returnable and may require extra-manufacturing time. Specify pitch when ordering.
2. Use limited to installations where complete roof penetration is non-combustible.

Materials Available:

Aluminum or Galvanized Steel	304	316
------------------------------	-----	-----

# TERMINATIONS

## STACK CAP

**USE:** Provides partial protection with low flow resistance. May require a drain at base of stack.

CODE: **SK**

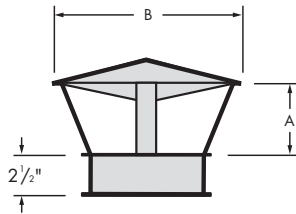

Part No.	Dim. A	Dim. B
5G-SK	2 1/2	10 1/4
6G-SK	3	10 1/4
8G-SK	4	13 3/8
10G-SK	5	17
12G-SK	6	20 1/2
14G-SK	7	24
16G-SK	8	27 3/8
18G-SK	9	30 3/4
20G-SK	10	34 1/8
22G-SK	11	37 5/8
24G-SK	12	41
26G-SK	13	44 3/8
28G-SK	14	47 7/8
30G-SK	15	51 1/4
32G-SK	16	54 5/8
36G-SK	18	61 1/2
42G-SK	21	71 3/4
48G-SK	24	82

$K = 0.5$  Flow Resistance Factor

Materials Available:

304	316
-----	-----

## EXIT CONE

**USE:** Will increase stack exit velocity 1 1/2 times. Requires a drain at the bottom of stack.

CODE: **EC**

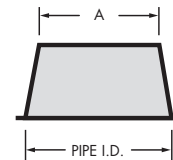

Part No.	Dim. A
5G-EC	4 7/8
6G-EC	4 7/8
8G-EC	6 9/16
10G-EC	8 3/16
12G-EC	9 7/8
14G-EC	11 1/2
16G-EC	13 1/16
18G-EC	14 3/4
20G-EC	16 5/16
22G-EC	18
24G-EC	19 3/8
26G-EC	21 1/4
28G-EC	2 7/8
30G-EC	24 1/2
32G-EC	26 1/8
36G-EC	29 3/8
42G-EC	34 5/16
48G-EC	39 3/16

$K = 0.5$  Flow Resistance Factor

Materials Available:

316
-----

# NOTES

---

# NOTES

---



BUILD FOR THE FUTURE

Customer Service and Support:

Airmate (USA).....	800.992.8368
Airmate (CAN) .....	888.735.5475
Ameriflow .....	800.252.8467
Amerivent (Retail).....	800.252.8467
Amerivent (Hearth & Wholesale) ....	800.423.4270
Amerivent (Support).....	800.748.0392
AMPCO (USA) .....	800.669.3269
AMPCO (CAN).....	888.735.5475
Duravent .....	800.835.4429
Hart & Cooley.....	800.433.6341
Hart & Cooley (Support) .....	800.748.0392
Heatfab (USA).....	800.772.0739
Heatfab (CAN) .....	800.848.2149
Lima.....	800.423.4270
Milcor .....	800.774.5240
Portals Plus.....	800.774.5240
RPS.....	800.624.8642
Security Chimney (USA).....	800.361.4909
Security Chimney (CAN) .....	800.667.3387
Selkirk (USA) Residential.....	800.992.8368
Selkirk (USA) Commercial.....	800.848.2149
Selkirk (USA) Support.....	800.748.0392
Selkirk (CAN).....	888.735.5475

Manufacturing & Distribution Centers:

CANADA	
Nobel, ON	Manufacturing
Laval, QC	Manufacturing
Prescott, ON	Distribution
USA	
Grand Rapids, MI	Center of Excellence
Dallas, TX	Distribution
Englewood, OH	Distribution
Huntsville, AL	Manufacturing & Distribution
Mira Loma, CA	Distribution
Nampa, ID	Manufacturing & Distribution
Turner Falls, MA	Manufacturing & Distribution
Vacaville, CA	Manufacturing
MEXICO	
Ojinaga, MX	Manufacturing
Mexicali, MX	Manufacturing

Corporate Headquarters:

Duravent Group  
 28 W. Adams, Suite 1810  
 Detroit, MI 48226  
 Tel: 800.835.4429  
 Email: [info@duraventgroup.com](mailto:info@duraventgroup.com)  
[www.duraventgroup.com](http://www.duraventgroup.com)



BUILD FOR THE FUTURE

[www.duraventgroup.com](http://www.duraventgroup.com)

