

Ultimate Plus™

6", 7", 8"

Factory-built CHIMNEY TYPE HT

INSTALLATION

AND

OPERATION

INSTRUCTIONS

TABLE OF CONTENTS

1. CERTIFICATION LABELS	2
2. RECOMMENDATIONS ET APPLICATIONS	3-4
3. MAINTENANCE	5-6
4. GENERAL INSTALLATION NOTES	7-10
5. INTERIOR STRAIGHT INSTALLATION - SINGLE FLOOR	11-12
6. INTERIOR STRAIGHT INSTALLATION - MULTIPLE FLOORS.	13-15
7. INTERIOR INSTALLATION CATHEDRAL CEILING	16-18
8. OFFSET DEVIATION, ADJUSTABLE LENGTH	19-22
9. UNIVERSAL COLLAR ASSEMBLY	23-24
10. EXTERIOR INSTALLATION	25-30
11. INTERIOR INSTALLATION - BOILER/FURNACE/WATER HEATER .	31-32
12. SPECIALIZED COMPONENTS	33-34
13. REPLACEMENT PARTS	35-37
14. INSTALLATION INFO	38

WARNING

A MAJOR CAUSE OF CHIMNEY-RELATED FIRES IS FAILURE TO MAINTAIN REQUIRED CLEARANCES (AIR SPACES) TO COMBUSTIBLE MATERIALS.

IT IS OF THE UTMOST IMPORTANCE THAT THIS CHIMNEY BE INSTALLED ONLY IN ACCORDANCE WITH THESE INSTRUCTIONS.

These instructions must be followed in all details.
Failure to do so may result in a hazardous installation.

Read these instructions and keep in a safe place for future reference.



Certified:
ETL #: - 4002244
- 5028194

Intertek

Tested/Certified to the
Following Standards:
UL103 TYPE HT
CAN / ULC-629
CAN / ULC-604



Selkirk Corporation
4460 44th Street S.E., Suite F
Grand Rapids, MI 49512
Toll Free: 1.800.992.VENT (8368)
info@selkirkcorp.com
www.selkirkcorp.com







Selkirk Canada Inc
P.O. Box 526, Depot 1,
Hamilton, ON L8L 7X6
Toll Free: 1.888.SELKIRK (735.5475)
cscanada@selkirkcorp.com
www.selkirkcorp.ca





Hart & Cooley LLC
4460 44th Street S.E., Suite F
Grand Rapids, MI 49512
Toll Free: 1.800.423.4270
info@hartandcooley.com
www.ameri-vent.com

LISTING LABELS AND WARNING LABEL ETCS277 (UP)

CERTIFIED TO / CERTIFIÉ UL-103 TYPE HT, CAN/ULC 629, CAN/ULC 604		
FACTORY-BUILT CHIMNEY REFER TO INTERTEK'S DIRECTORY OF BUILDING PRODUCTS (https://bpdirectory.intertek.com) FOR DETAILED INFORMATION. MINIMUM CLEARANCE TO COMBUSTIBLES: 2 IN. (50mm) AIR SPACE TO COMBUSTIBLE MATERIALS AND BUILDING INSULATION OR AS ESTABLISHED BY FACTORY FURNISHED FIRESTOP SPACERS AND SUPPORT ASSEMBLY. SUITABLE FOR INTERIOR OR EXTERIOR INSTALLATION THIS CHIMNEY IS TO BE INSTALLED IN ACCORDANCE WITH MANUFACTURER'S INSTALLATION INSTRUCTIONS.	CHEMINÉES PRÉFABRIQUÉES SE RÉFÉRER AU RÉPERTOIRE D'INTERTEK (https://bpdirectory.intertek.com) POUR PLUS D'INFORMATION. ESPACE LIBRE MINIMAL AUX MATÉRIEAUX COMBUSTIBLES: ESPACE LIBRE DE 2 PO. (50mm) AUX MATIÈRES COMBUSTIBLES ET À L'ISOLATION DE LA BÂTISSSE OU TEL QU'ÉTABLI PAR LES COUPE-FEU ET SUPPORTS FOURNIS PAR LE FABRICANT. CONVIENT À UNE UTILISATION À L'EXTÉRIEUR OU À L'INTÉRIEUR CETTE CHEMINÉE DOIT ÊTRE INSTALLÉE CONFORMÉMENT AUX MANUELS D'INSTALLATION DE DU FABRICANT.	
CANADIAN APPLICATION: - CERTIFIED TO CANULC 629 FOR CONNECTION TO SOLID, LIQUID OR GAS FIRED APPLIANCES NORMALLY PRODUCING FLUE GASES OF 650°C (1200°F) OR LESS. NOTE: ON WOOD/COAL BURNING APPLIANCE APPLICATION, PREMIUM SHIELDS ARE REQUIRED AROUND THE CHIMNEY FOR COMPLETELY ENCLOSED APPLICATION EXCEPT ON LISTED FACTORY BUILT FIREPLACES WHEN IT IS CERTIFIED WITH IT AND IDENTIFIED AS SUCH ON THE FIREPLACE LABEL. - CERTIFIED TO CANULC 604 FOR CONNECTION TO LIQUID OR GAS FIRED APPLIANCES NORMALLY PRODUCING FLUE GASES OF 540°C (1004°F) OR LESS.		
USA APPLICATION: - CERTIFIED TO UL 103 TYPE HT RESIDENTIAL TYPE AND BUILDING HEATING APPLIANCE CHIMNEY PART.		
MODEL - UP (6", 7", 8") - MODÈLE ENGLISH DESCRIPTION xxxxxxxxxxxxxxx FRENCH DESCRIPTION xxxxxxxxxxxxxxx PRODUCT CODEXXXXXX smart code xxxxxxx		code barre
SELKIRK CORPORATION CANADA INC. HART & COOLEY LLC. MM/DD/AAAA LV Work order		MADE IN / FABRIQUÉ AU CANADA NP380 REV. 02

CERTIFIED TO / CERTIFIÉ UL-103 TYPE HT, CAN/ULC 629, CAN/ULC 604		
ACCESSORIES FACTORY BUILT CHIMNEYS THIS CHIMNEY IS TO BE INSTALLED IN ACCORDANCE WITH MANUFACTURER'S INSTALLATION INSTRUCTIONS. REFER TO INTERTEK'S DIRECTORY OF BUILDING PRODUCTS (https://bpdirectory.intertek.com) FOR DETAILED INFORMATION. NOTE: ON WOOD/COAL BURNING APPLIANCE APPLICATION, PREMIUM THIRD SHIELDS ARE REQUIRED AROUND THE CHIMNEY FOR COMPLETELY ENCLOSED APPLICATION EXCEPT ON LISTED FACTORY BUILT FIREPLACES WHEN IT IS CERTIFIED WITH IT AND IDENTIFIED AS SUCH ON THE FIREPLACE LABEL.	ACCESSOIRES CHEMINÉES PRÉFABRIQUÉES CETTE CHEMINÉE DOIT ÊTRE INSTALLÉE CONFORMÉMENT AUX MANUELS D'INSTALLATION DU FABRICANT. SE RÉFÉRER AU RÉPERTOIRE D'INTERTEK (https://bpdirectory.intertek.com) POUR PLUS D'INFORMATION. NOTE: LE RACCORDEMENT SUR UN APPAREIL À COMBUSTIBLES SOLIDES REQUIERT L'UTILISATION DES COMPOSANTES COUPE RADIATION PREMIUM AUTOUR DE LA CHEMINÉE SI ELLE EST COMPLÈTEMENT ENCLOSEE; SAUF DANS LE CAS D'UN FOYER PRÉFABRIQUÉ HOMOLOGUÉ AVEC CE CONDUIT ET IDENTIFIÉ SUR L'ÉTIQUETTE D'HOMOLOGATION DU FOYER.	
CANADIAN APPLICATION: - CERTIFIED TO CANULC 629 FOR CONNECTION TO SOLID, LIQUID OR GAS FIRED APPLIANCES NORMALLY PRODUCING FLUE GASES OF 650°C (1200°F) OR LESS. NOTE: ON WOOD/COAL BURNING APPLIANCE INSTALLATION, PREMIUM SHIELDS ARE REQUIRED AROUND THE CHIMNEY FOR INTERIOR COMPLETELY ENCLOSED INSTALLATION EXCEPT ON LISTED FACTORY BUILT FIREPLACES WHEN IT IS CERTIFIED WITH IT AND IDENTIFIED AS SUCH ON THE FIREPLACE LABEL. - CERTIFIED TO CANULC 604 FOR CONNECTION TO LIQUID OR GAS FIRED APPLIANCES NORMALLY PRODUCING FLUE GASES OF 540°C (1004°F) OR LESS.		
USA APPLICATION: - CERTIFIED TO UL 103 TYPE HT RESIDENTIAL TYPE AND BUILDING HEATING APPLIANCE CHIMNEY PART.		
MODEL - UP (6", 7", 8") - MODÈLE ENGLISH DESCRIPTION xxxxxxxxxxxxxxx FRENCH DESCRIPTION xxxxxxxxxxxxxxx PRODUCT CODEXXXXXX smart code xxxxxxx		code barre
SELKIRK CORPORATION CANADA INC. HART & COOLEY MM/DD/AAAA LV Work order		MADE IN / FABRIQUÉ AU CANADA NP381 REV. 02

CERTIFIED TO / CERTIFIÉ UL-103 TYPE HT, CAN/ULC 629, CAN/ULC 604		
FACTORY-BUILT CHIMNEYS - CHEMINÉES PRÉFABRIQUÉES		
REFER TO INTERTEK'S DIRECTORY OF BUILDING PRODUCTS (https://bpdirectory.intertek.com) FOR DETAILED INFORMATION. MINIMUM CLEARANCE TO COMBUSTIBLES: 2 IN. (50mm) AIR SPACE TO COMBUSTIBLE MATERIALS AND BUILDING INSULATION OR AS ESTABLISHED BY FACTORY FURNISHED FIRESTOP SPACERS AND SUPPORT ASSEMBLY. SUITABLE FOR INTERIOR OR EXTERIOR INSTALLATION THIS CHIMNEY IS TO BE INSTALLED IN ACCORDANCE WITH SECURITY CHIMNEYS INTL.'S INSTALLATION INSTRUCTIONS.		
CANADIAN APPLICATION: - CERTIFIED TO CANULC 629 FOR CONNECTION TO SOLID, LIQUID OR GAS FIRED APPLIANCES NORMALLY PRODUCING FLUE GASES OF 650°C (1200°F) OR LESS. NOTE: ON WOOD/COAL BURNING APPLIANCE INSTALLATION, PREMIUM SHIELDS ARE REQUIRED AROUND THE CHIMNEY FOR INTERIOR COMPLETELY ENCLOSED INSTALLATION EXCEPT ON LISTED FACTORY BUILT FIREPLACES WHEN IT IS CERTIFIED WITH IT AND IDENTIFIED AS SUCH ON THE FIREPLACE LABEL. - CERTIFIED TO CANULC 604 FOR CONNECTION TO LIQUID OR GAS FIRED APPLIANCES NORMALLY PRODUCING FLUE GASES OF 540°C (1004°F) OR LESS.		
USA APPLICATION: - CERTIFIED TO UL 103 TYPE HT RESIDENTIAL TYPE AND BUILDING HEATING APPLIANCE CHIMNEY PART.		
APPLICATION AMÉRICAINE: - CERTIFIÉ UL 103 TYPE HT PIÈCE DE CHEMINÉE POUR APPAREIL DE CHAUFFAGE RÉSIDENTIEL ET COMMERCIAL.		
MODEL - ASHT, DTC, UP: 6", 7", 8" - MODÈLE ENGLISH DESCRIPTION xxxxxxxxxxxxxxx FRENCH DESCRIPTION xxxxxxxxxxxxxxx PRODUCT CODEXXXXXX smart code xxxxxxx		code barre
SELKIRK CORPORATION CANADA INC. HART & COOLEY LLC. MM/DD/AAAA LV Work order		MADE IN / FABRIQUÉ AU MEXICO NP380-1 REV. 01

CERTIFIED TO / CERTIFIÉ UL-103 TYPE HT, CAN/ULC 629, CAN/ULC 604		
ACCESSORIES FACTORY-BUILT CHIMNEYS THIS CHIMNEY IS TO BE INSTALLED IN ACCORDANCE WITH MANUFACTURER'S INSTALLATION INSTRUCTIONS. REFER TO INTERTEK'S DIRECTORY OF BUILDING PRODUCTS (https://bpdirectory.intertek.com) FOR DETAILED INFORMATION. NOTE: ON WOOD/COAL BURNING APPLIANCE INSTALLATION, PREMIUM THIRD SHIELDS ARE REQUIRED AROUND THE CHIMNEY FOR INTERIOR COMPLETELY ENCLOSED INSTALLATION EXCEPT ON LISTED FACTORY BUILT FIREPLACES WHEN IT IS CERTIFIED WITH IT AND IDENTIFIED AS SUCH ON THE FIREPLACE LABEL.	ACCESSOIRES CHEMINÉES PRÉFABRIQUÉES CETTE CHEMINÉE DOIT ÊTRE INSTALLÉE CONFORMÉMENT AUX MANUELS D'INSTALLATION DU FABRICANT. SE RÉFÉRER AU RÉPERTOIRE D'INTERTEK (https://bpdirectory.intertek.com) POUR PLUS D'INFORMATION. NOTE: LE RACCORDEMENT SUR UN APPAREIL À COMBUSTIBLES SOLIDES REQUIERT L'UTILISATION DES COMPOSANTES COUPE RADIATION PREMIUM AUTOUR DE LA CHEMINÉE SI LA CHEMINÉE EST INSTALLÉE À L'INTÉRIEUR. COMPLÈTEMENT ENCLOSEE; SAUF DANS LE CAS D'UN FOYER PRÉFABRIQUÉ HOMOLOGUÉ AVEC CE CONDUIT ET IDENTIFIÉ COMME TEL SUR SON ÉTIQUETTE D'HOMOLOGATION.	
CANADIAN APPLICATION: - CERTIFIED TO CANULC 629 FOR CONNECTION TO SOLID, LIQUID OR GAS FIRED APPLIANCES NORMALLY PRODUCING FLUE GASES OF 650°C (1200°F) OR LESS. NOTE: ON WOOD/COAL BURNING APPLIANCE INSTALLATION, PREMIUM SHIELDS ARE REQUIRED AROUND THE CHIMNEY FOR INTERIOR COMPLETELY ENCLOSED INSTALLATION EXCEPT ON LISTED FACTORY BUILT FIREPLACES WHEN IT IS CERTIFIED WITH IT AND IDENTIFIED AS SUCH ON THE FIREPLACE LABEL. - CERTIFIED TO CANULC 604 FOR CONNECTION TO LIQUID OR GAS FIRED APPLIANCES NORMALLY PRODUCING FLUE GASES OF 540°C (1004°F) OR LESS.		
USA APPLICATION: - CERTIFIED TO UL 103 TYPE HT RESIDENTIAL TYPE AND BUILDING HEATING APPLIANCE CHIMNEY PART.		
MODEL - ASHT, DTC, UP: 6", 7", 8" - MODÈLE ENGLISH DESCRIPTION xxxxxxxxxxxxxxx FRENCH DESCRIPTION xxxxxxxxxxxxxxx PRODUCT CODEXXXXXX smart code xxxxxxx		code barre
SELKIRK CORPORATION CANADA INC. DURAVENT INC. HART & COOLEY LLC. SECURITY CHIMNEYS INTL. MM/DD/AAAA LV Work order		MADE IN / FABRIQUÉ AU CANADA NP396 REV.00

CAUTION
WARNING: RISK OF FIRE. DO NOT ENCLOSE THIS SHIELD. REMOVE THIS RADIATION SHIELD BEFORE ENCLOSING THE CHIMNEY IN ATTIC SPACE. MAKE SURE NO HOUSE INSULATION IS IN CONTACT WITH THE CHIMNEY ABOVE THE ATTIC RADIATION SHIELD.
AVERTISSEMENT
ATTENTION: RISQUE D'INCENDIE. NE PAS PLACER CE COUPE-FEU DANS UNE ENCEINTE. RETIRER LE COUPE-FEU AVANT D'INSTALLER UNE ENCEINTE AUTOUR DE LA CHEMINÉE DANS LE GRENIER. ASSUREZ-VOUS QU'AUCUN MATÉRIEL ISOLANT NE SOIT EN CONTACT AVEC LA CHEMINÉE AU DESSUS DU COUPE-FEU DE GRENIER.
ETCS277 REV.01

RECOMMENDATIONS

It is important these installation instructions are followed.

We highly recommend this product be installed and serviced by professionals who are certified in the U.S.A by NFI (National Fireplace Institute) or CSIA or in Canada by WETT (Wood Energy Technology Transfer) or l'APC (l'association des professionnels du chauffage).

Clear the working space to give you freedom of movement during the installation. Be sure to clear any insulation that has been placed over the area where the chimney will penetrate the ceiling above the appliance.

Plan the installation of your appliance and chimney in such a way that both your chimney and your chimney connector (stovepipe) run is as short and straight as possible. By having too long and / or multiple offset installations you will reduce system draft which can affect the operation of your appliance and / or the chimney system. The chimney should be located within the building so as to avoid cutting or altering load bearing members such as joists, rafters, studs, etc. If you have to cut or alter an existing load bearing member, special reframing methods are required which often include doubling of adjacent members. If such a case arises, contact your local Building Code Official regarding local regulations and proper installation methods.

Sections of the UP chimney which pass through accessible areas of the building such as closets, storage areas, occupied spaces or any place where the surface of the chimney could be contacted by persons or combustible materials must be enclosed in a chase (framed in). The chase may be fabricated using standard building materials. Drywall mounted on 2" x 4" studs is typically used in this situation. Except for installation in single and two family dwellings, factory-built chimneys shall be enclosed with approved walls having a fire resistance rating equal or greater than that of the floor, wall or roof assemblies through which they pass.

Clearance

The clearances stated in this guide are minimum requirements: if more space is available, use it. Minimum clearances mean leaving unobstructed air space. Do not fill these spaces with any material whatsoever, especially not home insulating material except specified otherwise. If you insulate your attic later, be sure to maintain the necessary clearance.

Inspection

Prior to starting the installation, contact the local building officials in your area, to determine the need for any necessary building permits, and to ensure that your installation will conform with all local, provincial / state and national code requirements. Contact your insurance provider to determine if an inspection by a Certified Professional is required.

Replacement Parts

If a component of your chimney system is damaged it must be replaced by an identical one from Security Chimneys.

APPLICATIONS

UltimatePlus 6", 7", 8" chimney has been designed for use with wood, gas, oil in residential, commercial and industrial applications, specifically developed for use with controlled-combustion stoves and wood burning fireplace.

In **USA**:

UltimatePlus 6", 7", 8" is listed to UL-103 TYPE HT, for venting gas, liquid, and solid-fuel fired residential-type appliances and building heating appliances at a maximum continuous temperature of 1000°F.

In **CANADA**:

UltimatePlus 6", 7", 8" is listed to CAN/ULC-629, for use with gas, liquid and solid fuel-fired residential appliances and building heating equipment, where the flue-gas temperatures normally do not exceed 650 °C (1200°F).

Also listed to CAN/ULC-604 for use with gas and liquid fuel-fired residential appliances and building heating equipment, where the appliance or equipment flue-gas temperatures do not exceed 540 °C (1000 °F), such as furnaces, water heaters, and other appliances.

The installation should comply with the appropriate Installation Codes such as CSA-B365, CSA-B149 or CSA-B139 when installed in Canada, and the Installation Codes NFPA 211 NFPA 31 and NFPA 54 in the United States.

If you are planning to install a wood stove, we recommend that you:

1. Choose the right size stove. Do not buy one larger than you need.
2. Connect only one appliance to a chimney.
3. Never overfire your stove. If any part of the stove or stove pipe is glowing red, then you are overfiring. Immediately close the stove's dampers until the system cools. The high temperature caused by overfiring can permanently damage the stove and stove pipe and may overheat nearby combustible walls and furniture.
4. Install the stove and stove pipe as describes in the installation instructions accompanying the stove. Be certain to maintain the required clearances to combustible construction.
5. Keep your flue gases between 300°F and 500°F. This will maximize efficiency while minimizing condensation and creosote formation. Do not fill your stove with wood and allow it to smolder for 8 to 10 hours. This condition produces large amounts of creosote in the chimney.

6. Do not burn sea driftwood or treated wood. These combustibles are highly corrosive to all types of stainless steel.

FACTORY BUILT FIREPLACES

UP is suitable for use with closed or opened fireplaces certified for use with the UP.

When doing so please refer to the fireplace installation instruction for any specific requirement regarding the chimney.

CREOSOTE - FORMATION AND NEED FOR REMOVAL

When wood is burned slowly, it produces tar and other organic vapours, which combine with expelled moisture to form creosote. The creosote vapours condense in the relatively cool chimney flue of a slow-burning fire. As a result, creosote residue accumulates on the flue lining. **WARNING:** When ignited this creosote makes an extremely hot fire. UltimatePlus chimney is not intended nor been designed to be used as a combustion or fire chamber. By burning kindling, scrap lumber, brush or other fast burning fuel, you can over fire your system, which can produce flames and high temperatures all the way up the chimney. This can result in damages to the chimney and the appliance.

When using your appliance, we recommend that you:

1. Initially, inspect the chimney system weekly. You will learn how often it will be necessary to clean your chimney.
2. The chimney should be inspected at least once every 2 months during the heating season to determine if a creosote or soot build-up has occurred: if a significant layer of creosote has accumulated (3 mm or 1/8"), it should be removed to reduce the risk of chimney fire. Check spark arrestor screens at least every 2 to 4 weeks.
3. Have your chimney cleaned by a certified chimney sweep. If you want to clean your chimney yourself: clean your chimney using plastic or stainless steel brushes. Do not use a brush that will scratch the stainless steel interior of your chimney.
4. Do not expect chemical chimney cleaners to keep your chimney clean. Their use does not negate the necessity of periodically inspecting and a mechanical cleaning of the chimney.



WARNING

In Case of Fire: If a flue fire occurs, close all appliance dampers and source of combustion air, and call your Fire Department. Do not use the chimney again, until it has been inspected for possible damage.

SIZING CHART

CHIMNEY-SIZE	6"	7"	8"
OUTSIDE-DIAMETER	8"	9"	10"
FRAMING DIMENSION REQUIRED			
Reduced Clear. Support (IRCS)	10 1/8"	11 1/8"	12 1/8"
Square support (SCS)	12-1/8"	14-3/8"	14-3/8"
Ins. Wall Thimble (IWT)	12"	13-3/8"	14-3/8"
Round Support (RFSBT/ RFSDT)	12-1/8"	14-3/8"	14-3/8"
Firestop (FS) / Firestop Radiation Shield 10" (FRS10) / Floor Support Plate (FSP)	12-3/8"	13-3/8"	14-3/8"
Adj. Attic Insulation Shield (AAIS)	12-3/8"	13-3/8"	14-3/8"
MAX. SUPPORT HEIGHT **			
Tee Support (BTWS/AIWS)	63'	55'	48'
Roof Support (URS)	34'	27'	24'
Square Cat. Support (SCS)	60'	50'	45'
Reduced Clearance Support (IRCS)	60'	50'	45'
Round Support (RFSBT/ RFSDT)	75'	65'	59'
Offset/Wall Support (UWS)	28'	24'	20'
Insulated Tee (IT) *	63'	55'	50'
Anchor Plate (AP) and Floor Support Plate (FSP)	32'	32'	32'
Clearance To Combustibles	2"	2"	2"

* When installed on a concrete footing.

** NOTE: If greater height is required, use additional roof supports at intervals not exceeding 30'

Table 1

ROOF OPENING CHART

CHIMNEY SIZE	6"		7"		8"	
ROOF SLOPE	ROOF HOLE SIZE					
x/12	A	B	A	B	A	B
0	12-3/8	12-3/8	13-3/8	13-3/8	14-3/8	14-3/8
2/12	12-3/8	12-1/2	13-3/8	13-1/2	14-3/8	14-9/16
4/12	12-3/8	13	13-3/8	14-3/32	14-3/8	15-5/32
6/12	12-3/8	13-13/16	13-3/8	14-15/16	14-3/8	16-3/32
8/12	12-3/8	14-7/8	13-3/8	16-1/16	14-3/8	17-1/4
10/12	12-3/8	16-1/8	13-3/8	17-7/16	14-3/8	18-23/32
12/12	12-3/8	17-1/2	13-3/8	18-29/32	14-3/8	20-11-32

Table 2 - REFER TO FIGURE 1

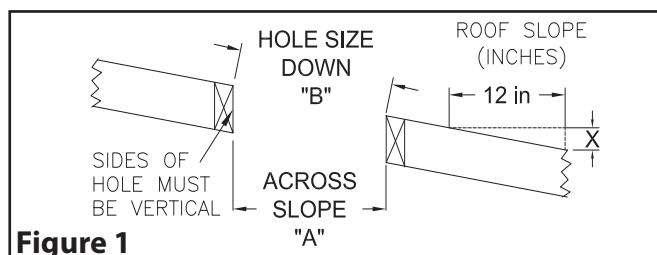

1 GENERAL INSTALLATION NOTES

INSTALLATION NOTES

1. UltimatePlus 6-8 is intended for use with solid, liquid, and gaseous fuel burning appliances for installation in the USA and Canada. Allowable flue gas temperatures:
Maximum continuous 1000° F (540°C) - USA.
Maximum continuous 1200° F (650°C) - Canada.
Brief forced firing 1400° F (760°C).
Tested to 2100° F (1150°C) - 3 x 30 minutes.
2. **CANADA ONLY:**
 - 2.A. When venting Wood or Coal Burning appliances installation for interior enclosed installation, Premium Radiation Shields accessories (Telescopic (TRLRS-3) or Flexible (FLRS-3 around the Chimney, and a Radiation Connector (RSC-3) at the ceiling level) are required around the chimney in Canada. Refer to specific Canadian installation notes for proper installation. (See **Figure 9, 15, 26**).
NOTE: When venting a Wood or Coal burning appliance installed within an exterior enclosure, PREMIUM Shield accessories are not required for exterior installation. In such cases, the enclosure need to maintain a minimum clearance of 3 inches on all 4x sides of the chimney. The Wall Support and Universal Wall Band will need to be adjusted to 3" clearance from vertical exterior wall.
 - 2.B. For venting of gas or oil burning appliances, PREMIUM Radiation Shields are not required.
 - 2.C. For factory-built wood burning fireplaces, PREMIUM Radiation Shields are usually not required. Refer to fireplace instructions
3. The maximum height of chimney supported by Ultimate Plus Chimneys' supports are outlined in **Table 1**
4. The supports described in this manual should only be used with UltimatePlus factory built chimney s' model UP, 6", 7", 8".
5. In order to achieve safe, optimum performance of the appliance, and service life of the chimney, the chimney should be sized correctly for the connected appliance; refer to the appliance manufacturer's instructions.
6. When a firestop is required, it is important to follow the framing dimensions for floor openings as prescribed in this manual. (**see Table 2**).
7. A chimney servicing a fireplace or an incinerator shall not serve any other appliance.
8. When proceeding to the installation of radiation shields and/ or attic insulation shields, the vertical height of the attic insulation shield or radiation shield above attic construction material should accommodate the amount of insulation as required by the National Building Code.
9. The chimney shall extend at least 3 ft above the highest point of contact where it passes through the roof and at least 2 ft higher than any wall, roof or adjacent building within 10 ft of it.
10. The maximum height of an unguided chimney above the roof is 5 ft. If the chimney extends more than 5 ft. above the roof, a Roof Brace KIT (RBK) must be used.
11. The clearance between single wall pipe and unprotected combustible material must not be less than 18" (see National Building Code and NFPA 211) except: The distance between the vertical stove pipe and the ceiling may be less than 18" and will be established by the ceiling support.
12. Where a factory-built chimney assembly extends through any story above that on which the connected appliance is located, it is to be provided with an enclosure which will maintain its required clearances. Apart from the above, installations in one and two family dwellings, a factory-built chimney that extends through any zone above that on which the connected appliance is located is to be provided with an enclosure having a fire resistance rating equal to or greater than that of the floor or roof assemblies through which it passes.
In addition, NFPA211 requires rated enclosures of any factory-built chimneys that pass through floors of buildings that the protection of vertical openings shall be enclosed with approved walls having a fire resistance rating of not less than one hour when such chimneys are located in a building less than 4 stories in height, and not less than 2 hours when such chimneys are located in a building 4 stories or more in height.
13. Do not fill the 2" space around the chimney with household insulation or any other material unless specified otherwise. Insulation placed in this area could prevent proper air circulation around the chimney and may cause adjacent combustible materials to overheat
IMPORTANT: Additional insulation around the chimney applies **ONLY** with:
 - Insulated Reduced Clearance Support (IRCS) and the Support Extension (RCSE),
 - Square Support (SCS) and the Support Extension (SCSE).Approved insulation can be used within the following supports and their extension. It must be listed/compliant with ASTM E136/ULC S114 as non-combustible, have a melting temperature above 2000°F/1100°C, and be water resistant with low moisture absorption. Materials such as rockwool or mineral wool qualify.
14. Self-tapping stainless screws are not required, but may be used to reinforce the connection and avoid accidental unlocking of chimney lengths. Use only 1/2" self-tapping screws. Do not penetrate the inner wall of the chimney.
15. When penetrating an exterior wall or ceiling/roof assembly, the vapor barrier must be repaired. This is easily accomplished by attaching the vapor barrier to the outer perimeter of any Firestop, Firestop Radiation Shield, Adjustable Attic Insulated Shield, Wall Shield or Ceiling Support components, using approved sealant or tape, while also maintaining the minimum clearances-to-combustibles to the chimney's outer wall. When penetrating the building envelope, the gap between the outer layer of chimney and any Wall Shields can be sealed using high-temperature rated (316°C / 600°F) silicone caulking. Should you require further clarification, consult your local authority having jurisdiction.

1

GENERAL INSTALLATION NOTES - CONT'D

16. The safe operation of a factory-built chimney assembly is based on the use of parts supplied by the manufacturer and the performance of the assembly may be affected if the combination of these parts are not used in actual building construction.

Acceptance of the assembly is void if the installation instructions are not followed.

17. Provisions must be made to ensure that all interior portions of the chimney be accessible for inspection and cleaning and cleaning.



WARNING

The clearance between the chimney and combustible material must not be less than 2" unless established by support. Do not fill this area with insulation unless directed otherwise in these instructions.

ULTIMATEPLUS - JOINT ASSEMBLY

-1. For a joint assembly, when assembling joints between pipe lengths, you can optionally slip the locking band loosely over the inverted bead on one end first and then, simply lower the top length onto a lower length until the inlet end (female end) is fully seated over the outlet end (male end) See **Figure 2a**.

In order to reduce the risk of scratching the section while sliding the locking band over the section, here is another way: lower the top length onto a lower length until the inlet end (female end) is fully seated over the outlet end (male end) and then, slip the locking band down the pipe length to the beads. See **Figure 2b**.

NOTE: sectional overlap is 1-1/8".

-2. Ensure the inlet end (female end) of the pipe is fully seated on the outlet end (male end) of the pipe.

-3. Insert the Locking band into the inward bead located on both ends. Once fully engaged in the inward beads, secure locking band with the securing latch into the farthest lance (2nd lance), see **Figure 3**.

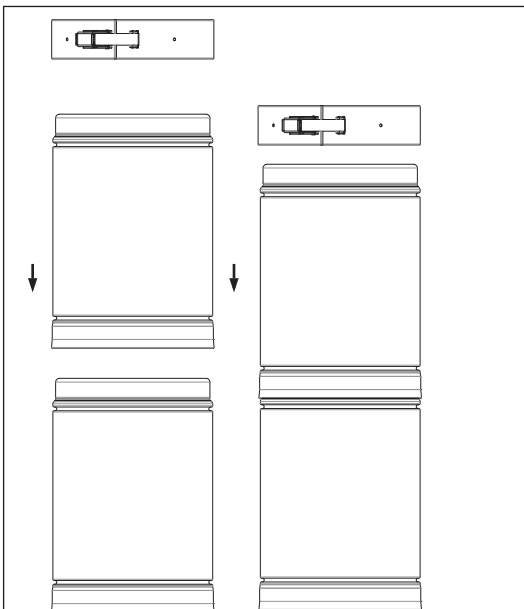

Figure 2a

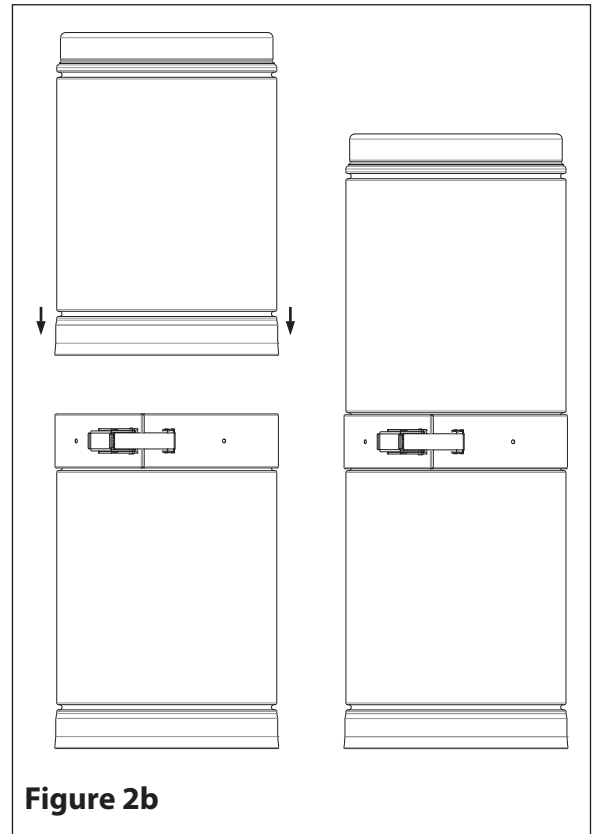

Figure 2b

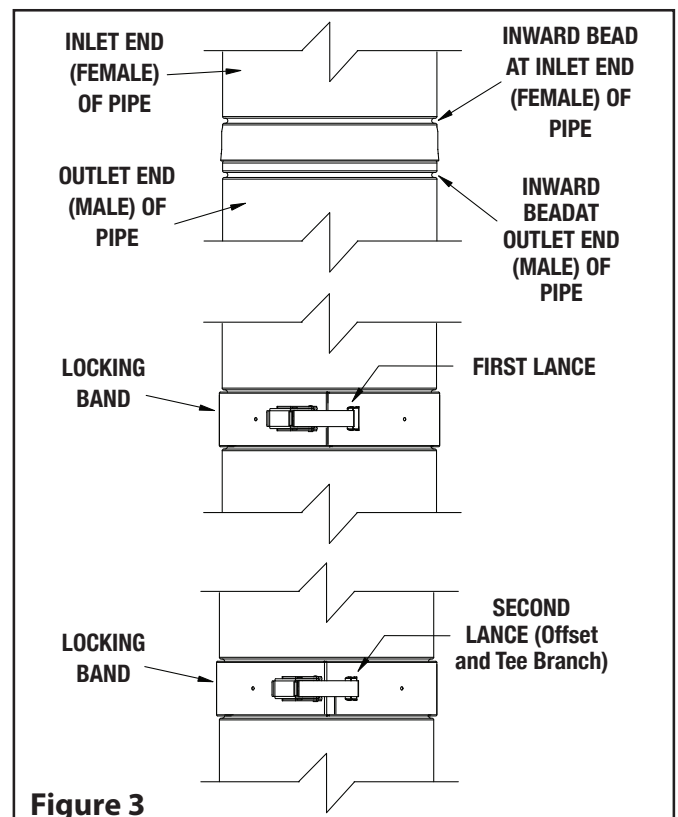

Figure 3

1

GENERAL INSTALLATION NOTES (CONT'D)

ULTIMATEPLUS-ALTERNATE JOINT SECURING

As an alternate to the Locking Band, you can secure the joint with four (4) - #8 x 3/4" A/AB stainless steel screws (not supplied) Pre-drill if necessary. Must be evenly spaced, 1/2" from the end of the pipe. See **Figure 4**, showing Securing Diagram (Close up, Cross-Section of Chimney Joint).

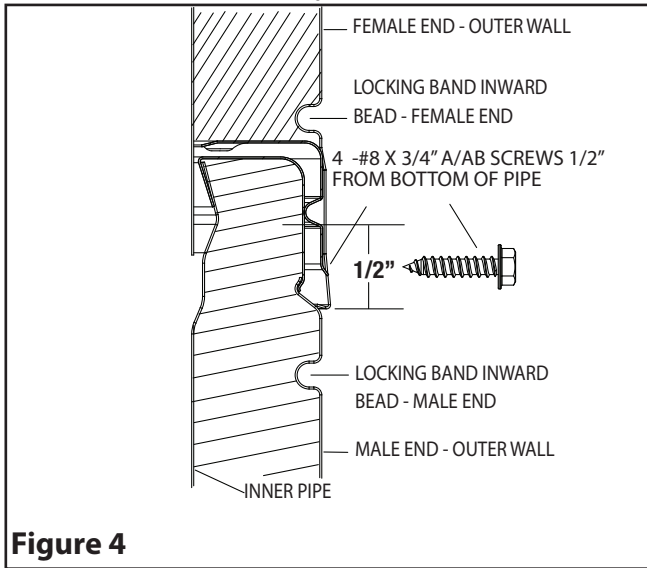

Figure 4

ELBOWS AND TEE BRANCH

Locking Bands and 3 sheet metal screws must be used on all joints forming an offset and at the Tee Branch joint.

- Must latched into the furthest lance (2nd lance **Fig 3**).
- Secured with three (3) - #8 x 3/4" A/AB Stainless Steel screws, using the pre-pierced holes on each side of the latch and one opposite the latch through the locking band into the joint.

ROUND TOP (CT)

Install the Round Top (CT) on the top section. Make sure the legs are on the outside of the chimney. position the cinch band over the legs and secure in place using the bolt and captured nut.

To remove the Round Top from the chimney for inspection and maintenance, remove the cinch band and lift the Round Top off. Reverse to re-install.

NOTE: A Spark Arrestor (USA) is available. The preformed one piece simply slides over the Round Top with the flanged edge on top of the dome.

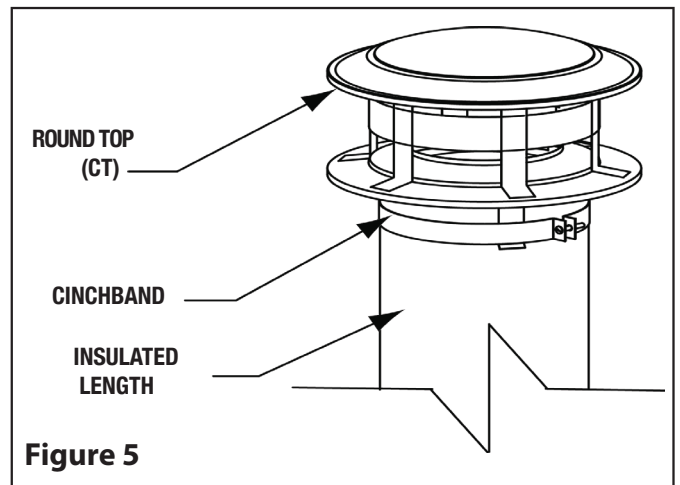
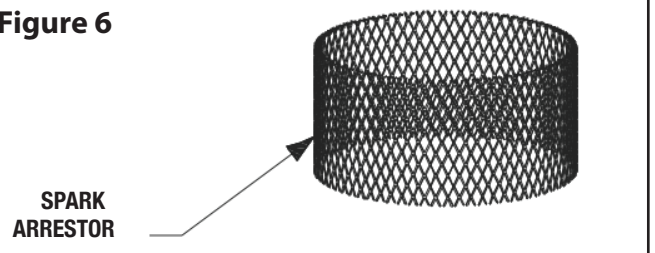

Figure 5

Figure 6



ULTIMATEPLUS - SMOKE PIPE ADAPTOR (SPA)

The Smoke Pipe Adaptor is secured to the female end of a chimney length with 3 sheet metal screws (supplied) using the 3 angled brackets. Lower the prepared length into the support making sure it extends through the support opening.

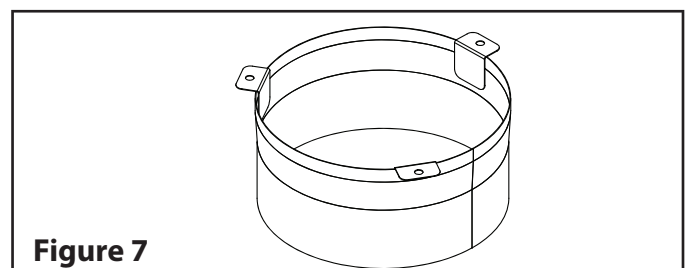

1

GENERAL INSTALLATION NOTES (CONT'D)

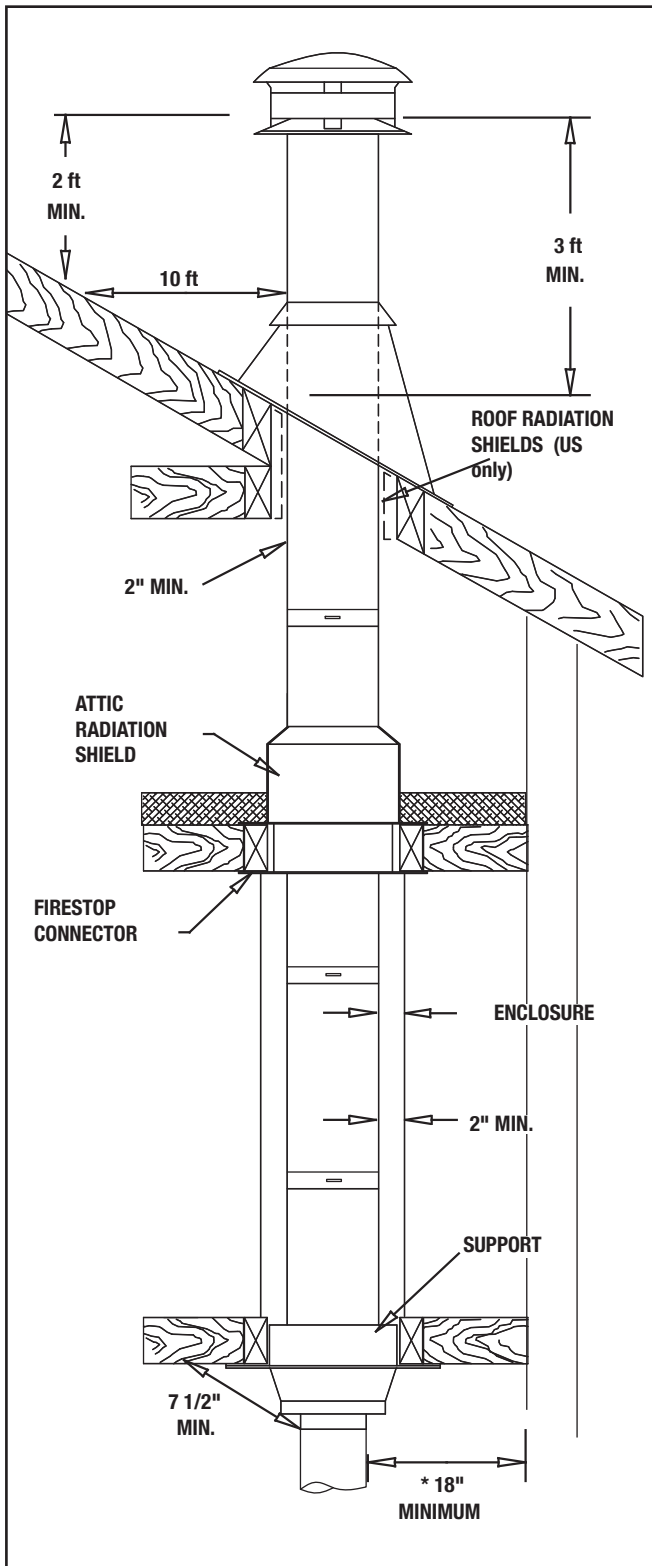

Figure 8 - USA - Standard Installation layout IN A COMBUSTIBLE ENCLOSURE

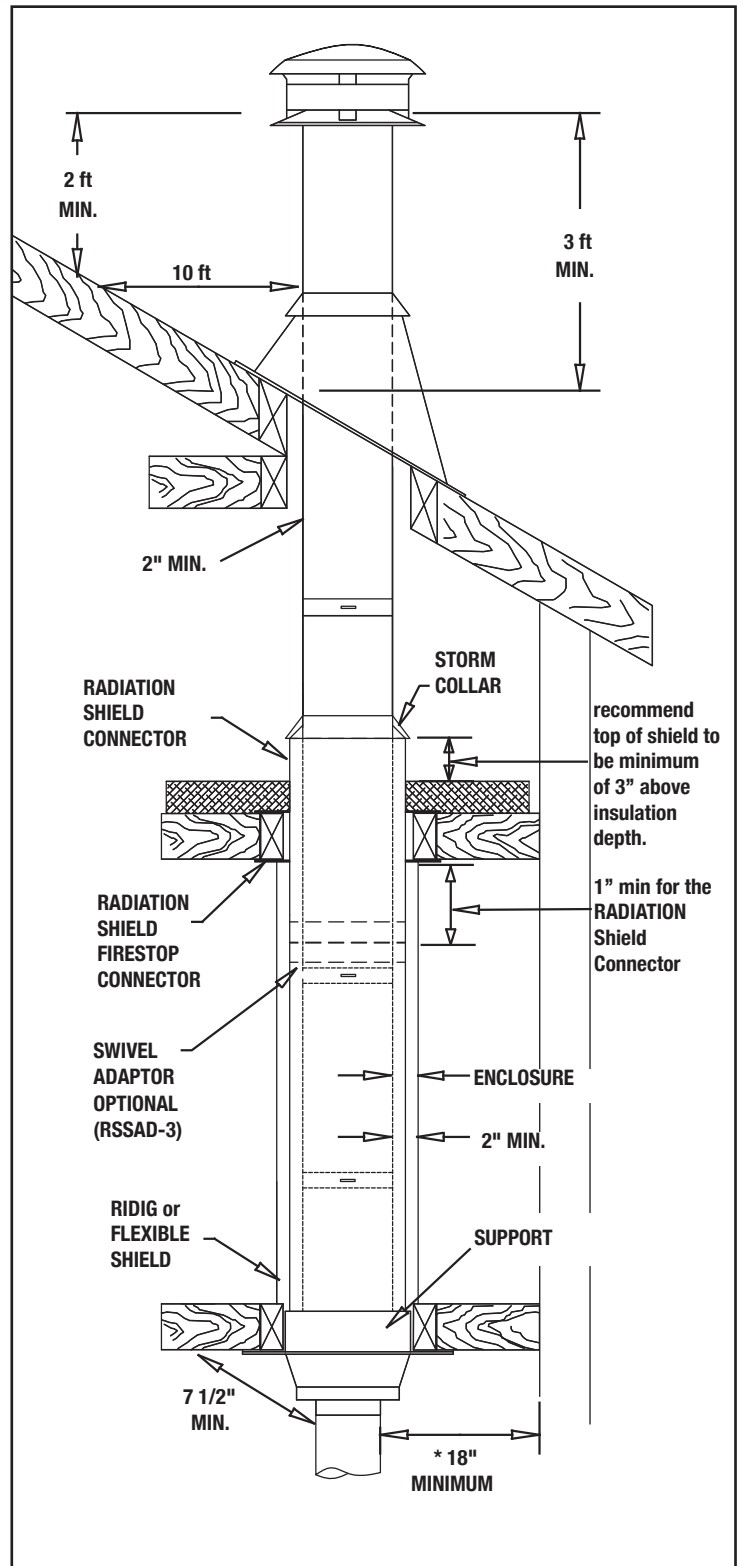

Figure 9 - CANADA - PREMIUM Radiation Shields Installation layout IN A COMBUSTIBLE ENCLOSURE.

* CLEARANCE CAN BE REDUCED IF A LISTED CHIMNEY CONNECTOR IS USED.

** CLEARANCES CAN BE LESS THAN 2" WHERE ESTABLISHED BY THE SUPPORT.

2

INTERIOR STRAIGHT INSTALLATION - SINGLE FLOOR

INSULATED REDUCED SUPPORT (IRCS) INSTALLATION

When using the Insulated Reduced Clearance Support (IRCS) at the attic level, the use of the adjustable attic insulation shield (AAIS) is not required. The Insulated Reduced Clearance Support (IRCS) acts as an attic radiation shield when installed with insulation and collar (provided).

NOTE: A Round Support (RFSBT) combined with an Adjustable Attic Insulation Shield (AAIS) can also be used for this application. Refer to **Section 3** for installation guide.

Step 1: Locate the chimney in a convenient place as near as possible to the appliance outlet.

Step 2: Cut and frame the opening in the ceiling and roof where the chimney will pass.

NOTE: It is important to follow the framing dimensions for floor openings as prescribed in this manual.

Step 3: From below, push the Insulated Reduced Clearance Support into the framed opening in the ceiling. Ensuring the support is level, attach the support to the framed opening using (12) - 3" spiral nails or #8 x 1 1/2" wood screws (see **Figure 10**). A minimum of 3 1/2" of the support must extend into the room. Screw the Finish Trim (included) to the ceiling.

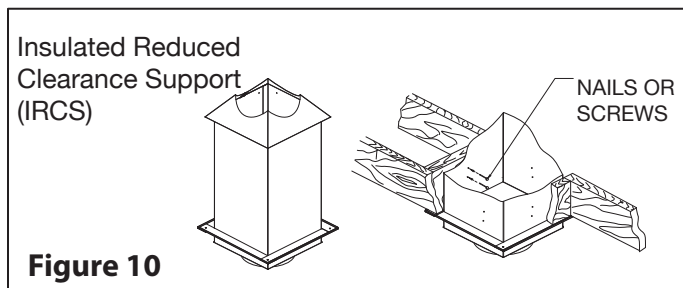

NOTE: A minimum of 3 1/2" of the support must extend down below the finished ceiling. This ensures minimum clearances are maintained to stovepipe. Fix the Finish Trim around the support using supplied screws. Refer to **Figure 11** for visual.

CHIMNEY SIZE	FRAMING DIMENSION	
	Insulated Reduced Clearance Support	ROOF
6"	10-1/8" x 10-1/8"	12-3/8" x 12-3/8"
7"	11-1/8" x 11-1/8"	13-3/8" x 13-3/8"
8"	12-1/8" x 12-1/8"	14-3/8" x 14-3/8"

Table 3

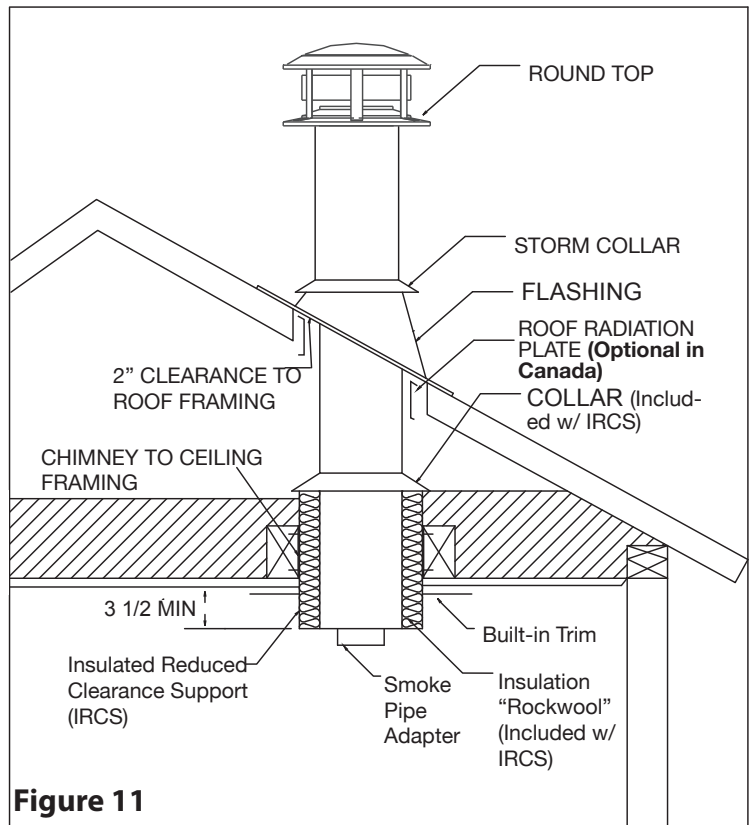

Step 4: Before lowering the chimney length into the support, install the Smoke Pipe Adapter (see Figure 7). Wrap the insulation pad around the chimney section removing any excess. Lower this first chimney length in the support. Make sure the Smoke Pipe Adapter protrudes through the opening of the support. Slide insulation pad into the space between the chimney section and support making sure the insulation makes contact with the bottom of the support. Additional pieces of insulation can be loosely tucked down within corners. Do not compress insulation. This reduces effectiveness.

NOTE: If needed a Support Extension (RCSE) can be attached to the support to increase its height. See **Section 4: Reduced Clearance Support Extension**.

NOTE: Make sure arrow on pipe label is pointing upward.

Step 5: The square-to-round collar (included) features a fixing tab and slot. To install, wrap the collar around the chimney.

Slide it down on top of the RCS Support.

Pull the sides of the collar together while inserting the collar's tab through the slot.

Once tight, fold the tab over to secure the collar. Check fit to ensure the collar completely covers the top of the support.

Step 6: Stack the next chimney length on the first length until fully seated. Install a Locking Band to secure the joint. Continue until the required chimney height is reached. See **Section 1: UltimatPlus - Joint Assembly**

Step 7: **(US only) - ROOF RADIATION SHIELD**

Install the Roof Radiation Shield in the roof frame opening. This shield consists of (4) metal plates supplied with the Roof Flashing. Nail one plate to each side of the frame opening using (2) - 2 1/2" nails while making sure each plate is centered.

Step 8: **ROOF FLASHING INSTALLATION**

Put the roof flashing in place. Seal the joint between the roof and the flashing with roofing compound.

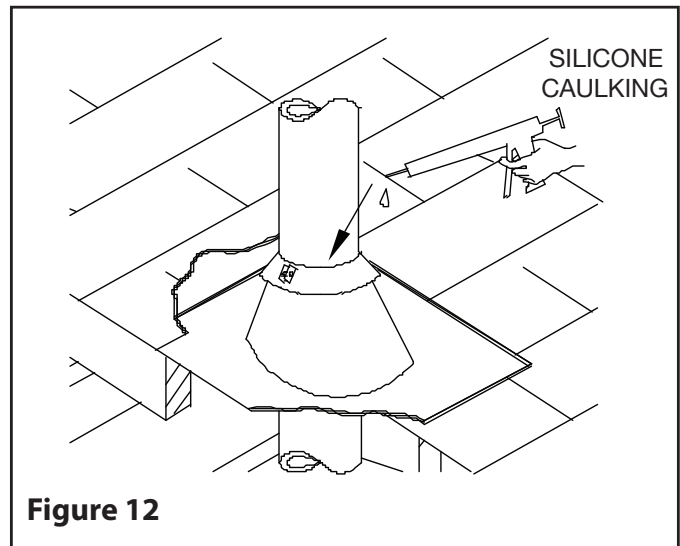

Figure 12

For sloping roofs, place the flashing under the upper shingles and on top of the lower shingles. Nail the flashing to the roof using nails. Place the storm collar around the chimney and slide down on top of the flashing.

Step 9: Tighten the collar using the supplied bolt. Make sure the joint is properly caulked (see **Figure 12**).

Step 10: Attach the Round Top (CT) to the chimney (see **Figure 5**).

3

INTERIOR STRAIGHT INSTALLATION - MULTIPLE FLOOR

If using the Reduced Clearance Support (IRCS), refer to Table 3 for dimensions. When used for this application, the square-to-round collar is not used.

When using the IRCS, installer must always consider obstacles above that could encroach on or compromise clearances truss top chord and diagonal webs etc. Clearance reduction only applies to portion of chimney protected by the support and the support extension.

ROUND SUPPORT (RFSBT) INSTALLATION

Step 1: Locate the chimney in a convenient place as near as possible to the appliance outlet.

Step 2: Cut and frame the openings in the floor, ceiling and roof where the chimney will pass.

NOTE: It is important to follow the framing dimensions for the floor and roof openings prescribed in this manual.

CHNMNEY SIZE	HOLE OPENING SIZE	
	FINISH SUPPORT (RFSBT)	RADIATION SHIELD FIRESTOP CONNECTOR (RSFC-3) & ROOF*
6"	12-1/8" x 12-1/8"	12-3/8" x 12-3/8"
7"	14-3/8" x 14-3/8"	13-3/8" x 13-3/8"
8"	14-3/8" x 14-3/8"	14-3/8" x 14-3/8"

Step 3: From below push the Round Support into the framed opening. Nail or screw the support to the framed box using (12) 3" spiral nails or #8 x 1 1/2" wood screws (see Figure 13). Refer to Figures 5 and 14 for visual.

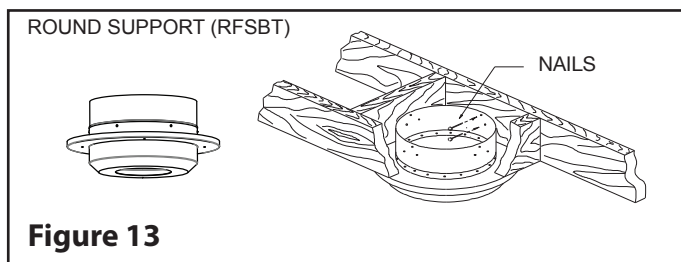

Step 5.1: FOR UNENCLOSED INSTALLATION OR VENTING OF OIL OR GAS APPLIANCES (See Figure 14), proceed according to Step 5.1A to Step 5.1E below.

Step 5.1A: Before lowering the chimney length into the support, install the Smoke Pipe Adapter (see Page 10). Lower the prepared chimney length in the support. Make sure it protrudes through the opening of the support.

NOTE: Arrow on pipe label must be pointing up.

Step 5.1B: From below, install a Firestop (FS) at each ceiling through which the chimney passes.

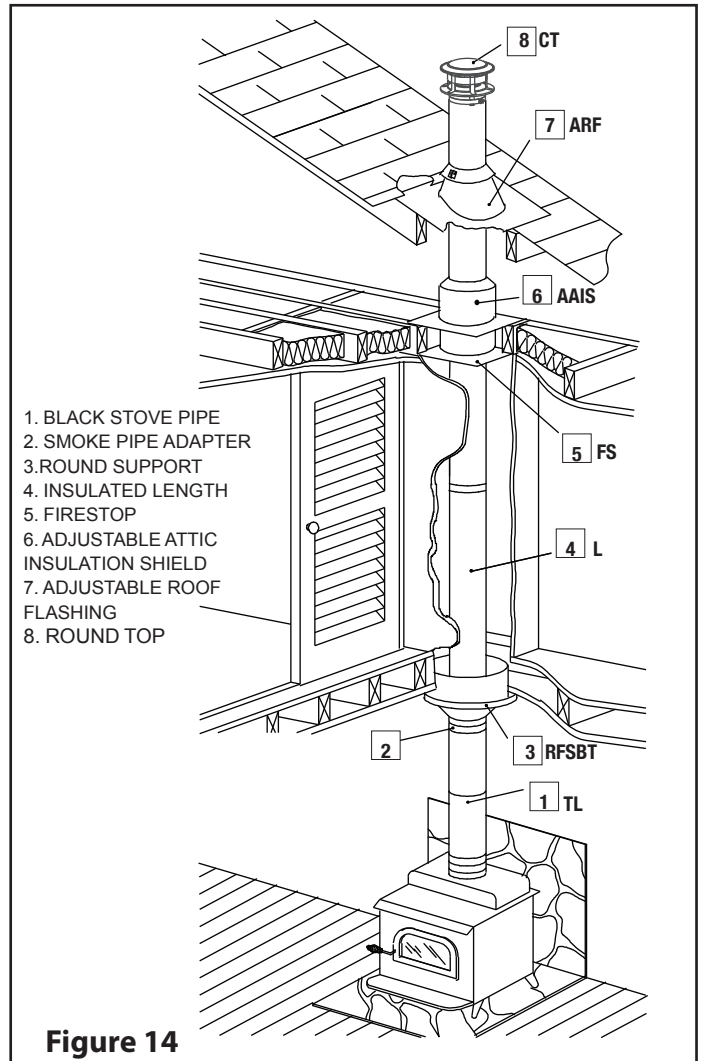

Figure 14

Step 4: **IN CANADA ONLY**, If you are venting a Factory built fireplace or an oil or gas burning appliance please refer to installation notes #1 (on Section 1) for guidelines on the use of the Premium shields.

Step 5.1C: Stack the next chimney length on the first length until fully seated. Install a Locking Band to secure the joint. For Joint Assembly. Continue until the required chimney height is reached. See Section 1: UltimatePlus - Joint Assembly.

3

INTERIOR STRAIGHT INSTALLATION - MULTIPLE FLOOR (CONT'D)

Step 5.1D: At the attic level, install a Firestop (FS or FRS10) on underside of frame at ceiling. The Attic Radiation Shield (AAIS) must be installed on its baseplate atop the frame from above. Secure to framing with 1" wood screws. (see **Figure 15**).

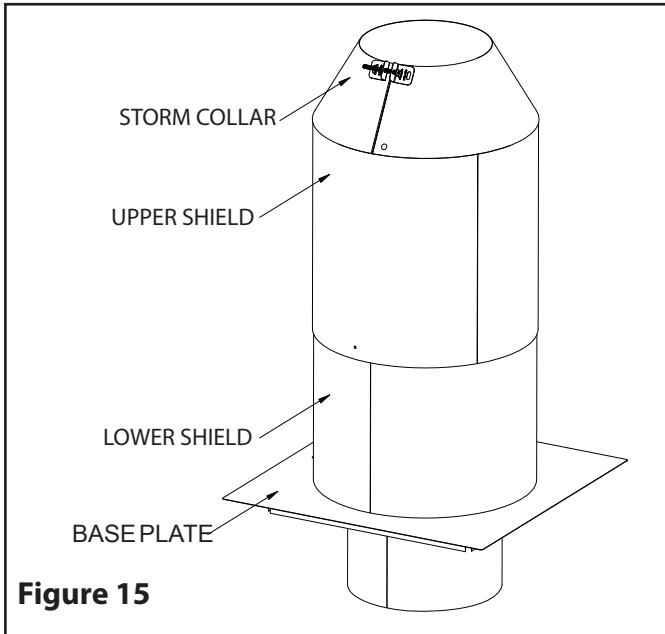

Figure 15

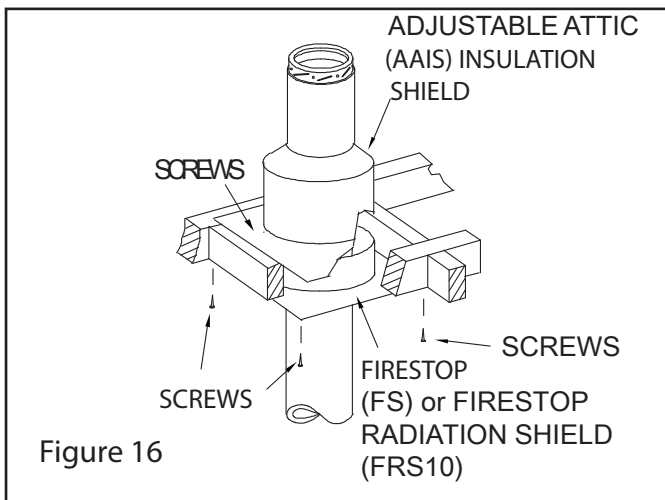

Figure 16

The Adjustable Attic Insulation Shield (**Figure 16**) is designed to keep insulation materials from coming into contact with the chimney. Adjustable from 12" to 22", it must meet the insulation level requirement of the National Building Code. Attic insulation must be 2" below the storm collar. Minimum overlap of 1" is required prior to securing the 2 halves (Upper and Lower Shields) together. **See Figure 15**.

NOTE: If a joint is to be located within the Attic Insulation Shield, you will need to substitute the Locking Band with 4 sheet metal screws instead (refer to **Figure 4**).

Step 5.1E: (**US only**) - **ROOF RADIATION SHIELD.**

Install the Roof Radiation Shield in the roof frame opening. This shield consists of (4) metal plates supplied with the Roof Flashing. Nail one plate to each side of the joists using (2) - 2 1/2" nails.

Step 5.2: (**CANADA ONLY**)-FOR ENCLOSED INSTALLATION ON WOOD OR COAL BURNING APPLIANCE (See **Figure 17**), proceed according to Step 5.2A to Step 5.2F below.

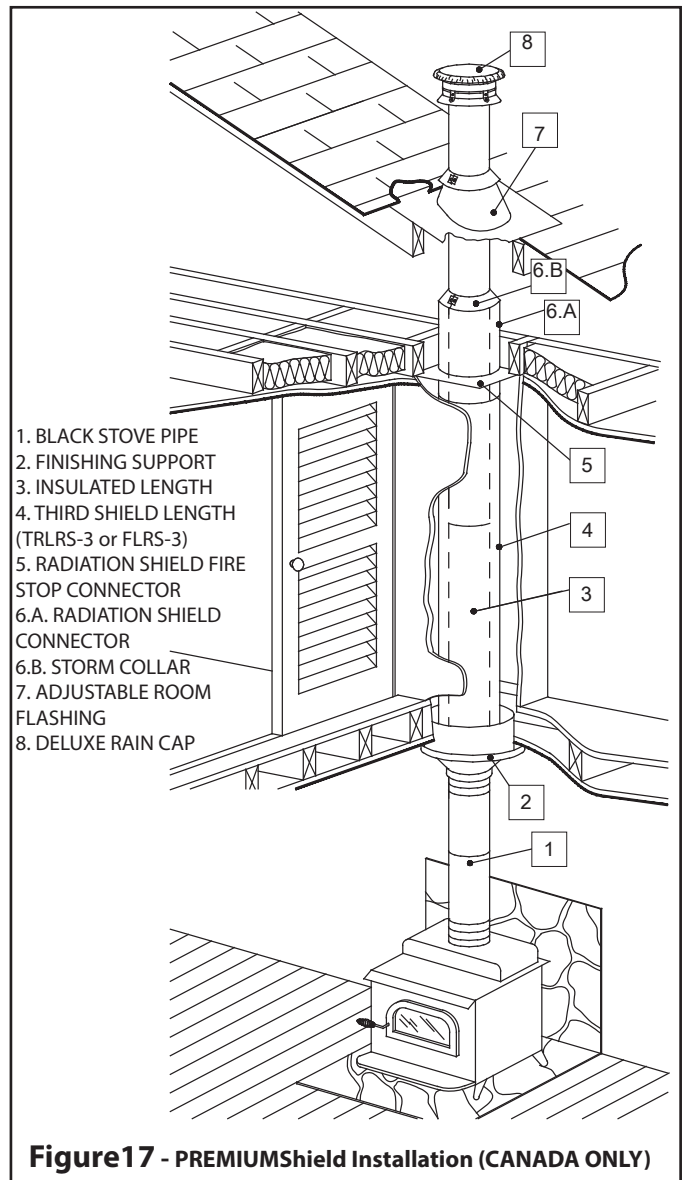

1. BLACK STOVE PIPE
2. FINISHING SUPPORT
3. INSULATED LENGTH
4. THIRD SHIELD LENGTH (TRLRS-3 or FLRS-3)
5. RADIATION SHIELD FIRE STOP CONNECTOR
- 6.A. RADIATION SHIELD CONNECTOR
- 6.B. STORM COLLAR
7. ADJUSTABLE ROOM FLASHING
8. DELUXE RAIN CAP

Figure 17 - PREMIUMShield Installation (CANADA ONLY)

3

INTERIOR STRAIGHT INSTALLATION - MULTIPLE FLOOR (CONT'D)

Step 5.2A: Before lowering the chimney length into the support, install the Smoke Pipe Adapter (see **Page 10**). Lower the prepared chimney length in the support. Make sure the smoke pipe adapter protrudes through the opening of the support the smoke pipe adapter.

NOTE: Arrow on pipe label must be pointing up.

Step 5.2B: Slide a Telescopic Rigid shield (TRLRS-3) on top of that length all the way to the bottom.

STEP 5.2C Stack the next chimney length on the first length. To secure the joint of the sections, please refer to the JOINT ASSEMBLY or ALTERNATE JOINT SECURING in **Section 1, Figure 4**. Continue installing until the chimney reached the ceiling.

Step 5.2D: At the ceiling level, install a Radiation Shield Connector (RSC-3) and a Radiation Shield Firestop (RSFC-3). Slide the Radiation Shield Connector down until the bottom of the insulated tube extend past the Radiation Shield Firestop as shown in (see **Figure 18A**). Adjust the height until a minimum of (1") of the Radiation Shield Connector extend below the firestop.

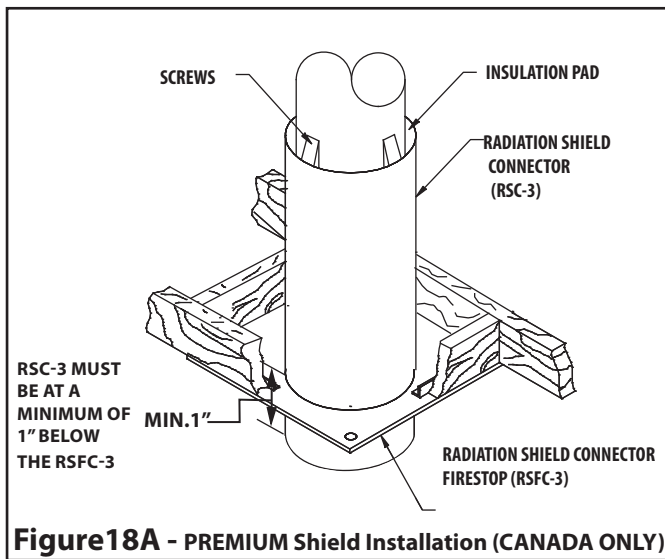

Figure 18A - PREMIUM Shield Installation (CANADA ONLY)

Step 5.2E: Fix it to the chimney from the attic side using (3) - 1/2" self-tapping screws.

Step 5.2F: The Telescopic Shield is then slid upwards to the ceiling and attached to the bottom of the Radiation Shield Connector using (3) - 1/2" self-tapping screws.

Recommended: add one stainless steel self tapping screws provided, between each telescopic section, to reinforce telescopic joints.

Step 5.G: A Storm Collar (included with RSC-3) must be installed on top of Radiation Shield Connector (RSC-3) to prevent any loose insulation from falling in the area between the chimney and the support. (See **Figure 18B**)

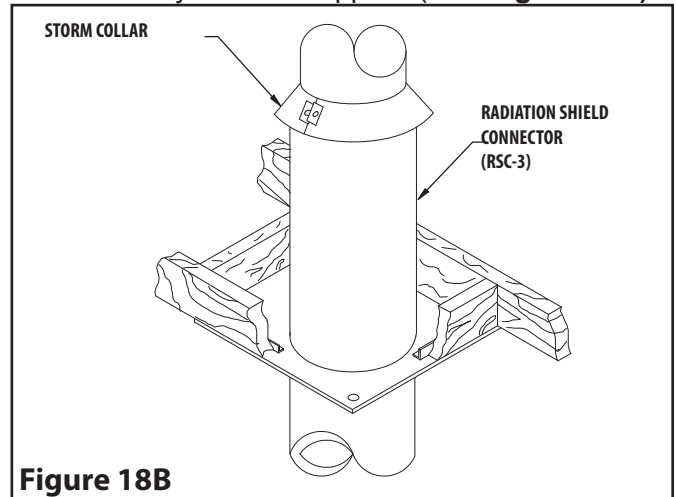

Figure 18B

Step 6: ROOF FLASHING INSTALLATION

Install the Roof Radiation Shield in the roof frame opening. This shield consists of (4) metal plates supplied with the Roof Flashing. Nail one plate to each side of the frame opening using (2) - 2 1/2" nails.

For sloping roofs, place the flashing under the upper shingles and on top of the lower shingles. Nail the flashing to the roof using roofing nails. Place the storm collar over the chimney and the flashing. Tighten it with the bolt supplied making sure the joint is properly caulked (see **Figure 19**).

ATTENTION! Do not block the space between the flashing and the chimney. It is required to be fully open for the purpose of ventilation.

Step 7: Attach the Round Top (CT) to the top of the chimney. See Section 1: **Round Top (CT)**.

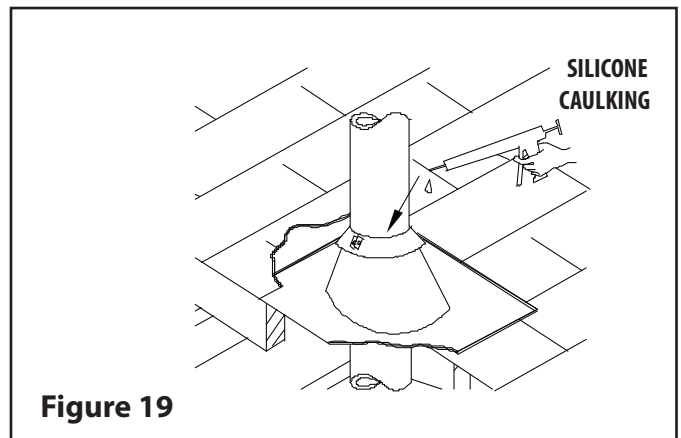

Figure 19

4

INTERIOR INSTALLATION CATHEDRAL CEILING

NOTE: The Insulated Reduced Clearance Support (IRCS) comes with a collar. It can be discarded for a Cathedral Ceiling application, it is not required (see Figure 21).

Step 1: Locate the chimney in a convenient location as near as possible to the appliance outlet. Cut and frame an opening in the roof for the support (see **Table 5**). The sides of this hole must be vertical (**See Figure 21**).

Step 2: From above, place the support in the opening.

NOTE: The bottom portion of the support must project below the ceiling. Distance will vary according to pitch (see **Table 6**). The minimum horizontal distance between single wall stove pipe and adjacent wall surfaces is 18”.

Step 3: Use a level to ensure the support is vertical. If the support extends above the roof, cut it flush with the top of the roof. Attach the support to the framed opening using (12)-3” spiral nails or #8 x 1 1/2” wood screws (see **Figure 20**).

Step 4: Before lowering the chimney length into the support, install the Smoke Pipe Adapter (see **Section 1**). Lower this first chimney length in the support. Make sure the Smoke Pipe Adapter protrudes through the opening of the support. Wrap the insulation pad around the chimney section removing any excess. Slide insulation pad into the space between the chimney section and support making sure the insulation makes contact with the bottom of the support. Additional pieces of insulation can be loosely tucked down within corners. Do not compress insulation. This reduces effectiveness.

Where desired, an extension (RCSE) is available for the support. This may be needed in steeper cathedral applications.

NOTE: See Section 1: GENERAL INSTALLATION'S NOTES step 13. for approved insulation.

TO CONTINUE INSTALLATION REFER TO STEP 5.1 or 5.2 IN Section 3.

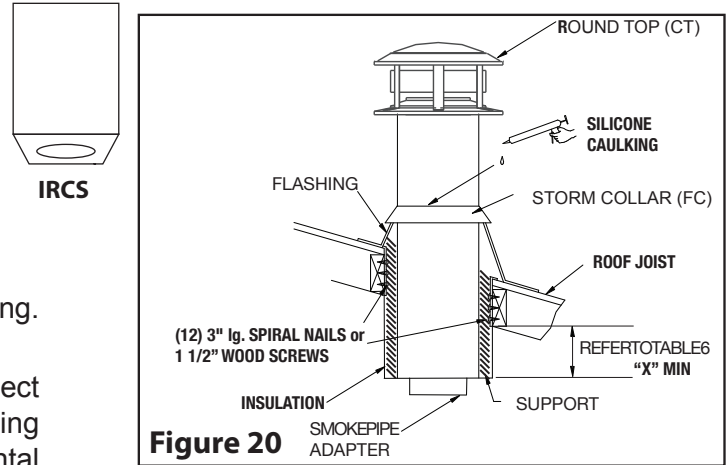

Figure 20

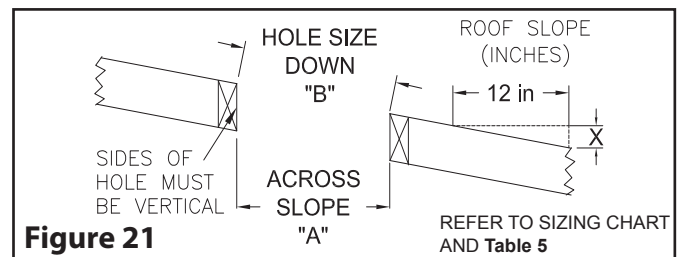

Figure 21

Chimney Size	6"		7"		8"	
	Frame Opening (Reduce Clearance Support)					
Roof Slope (X/12)	A	B	A	B	A	B
0	10-1/8	10-1/8	11-1/8	11-1/8	12-1/8	12-1/8
2/12	10-1/8	10-1/4	11-1/8	11-1/4	12-1/8	12-1/4
4/12	10-1/8	10-5/8	11-1/8	11-3/4	12-1/8	12-3/4
6/12	10-1/8	11-1/4	11-1/8	12-1/2	12-1/8	13-1/2
8/12	10-1/8	12-1/8	11-1/8	13-1/4	12-1/8	14-1/2
10/12	10-1/8	13-1/4	11-1/8	14-1/2	12-1/8	15-7/8
12/12	10-1/8	14-1/4	11-1/8	15-3/4	12-1/8	17-1/8

Table 5

NOTE: ALL DIMENSIONS ARE IN INCHES.

4

INTERIOR INSTALLATION CATHEDRAL CEILING (CONT'D)

Reduce Clearance Support Extension (RCSE)

Steep pitched cathedral ceilings may require the use of a Support Extension (RCSE). This piece fits down inside the reduced clearance support and can be adjusted to increase the support's length by up to 22".

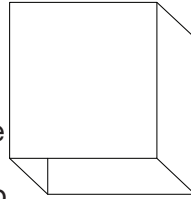

RCSE

The extension is attached to the support using the eight metal screws provided. Be sure there is at least a 2" overlap where the extension joins the support.

NOTE: Refer to (Section 1: GENERAL INSTALLATION'S NOTES step 13.) under General Installation Notes regarding additional insulation required with this extension.

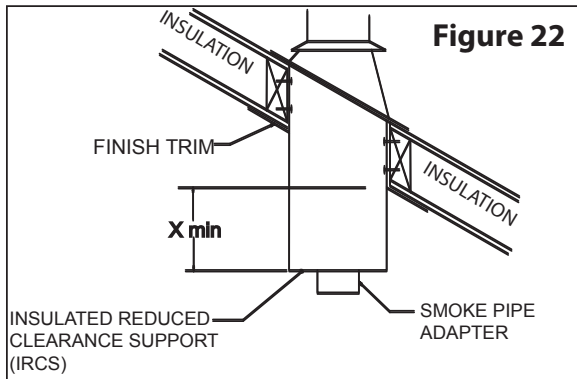

Slope	X min
0/12 - 2/12	3 1/2"
2/12 - 7/12	5 1/2"
7/12 - 12/12	6 3/4"
12/12 - 24/12	7 1/2"
24/12	12 1/12"

Table 6

4

INTERIOR INSTALLATION WITH CATHEDRAL CEILING (CONT'D)

SQUARE SUPPORT

This support is similar in application and installation as the Reduced Clearance Support. Install it using the instructions on page 11 (refer to **Figure 23** for visual references).

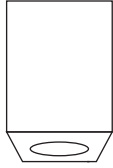

SCS

NOTE: Refer to (**Section 1: GENERAL INSTALLATION'S NOTES step 13.**) under General Installation Notes regarding approved insulation to use with this

SUPPORT EXTENSION (SCSE) (For Square Support)

Steep pitched cathedral ceilings may require the use of a Square Support extension (SCSE). This piece fits down inside the square support and can be adjusted to increase the support's length by up to 22".

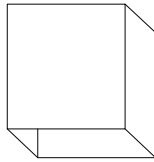

SCSE

The extension is attached to the support using the eight (8) metal screws provided. Be sure there is at least a 2" overlap where the extension joins the support.

NOTE: Refer to (**Section 1: GENERAL INSTALLATION'S NOTES step 13.**) under General Installation Notes regarding approved insulation to use with this extension.

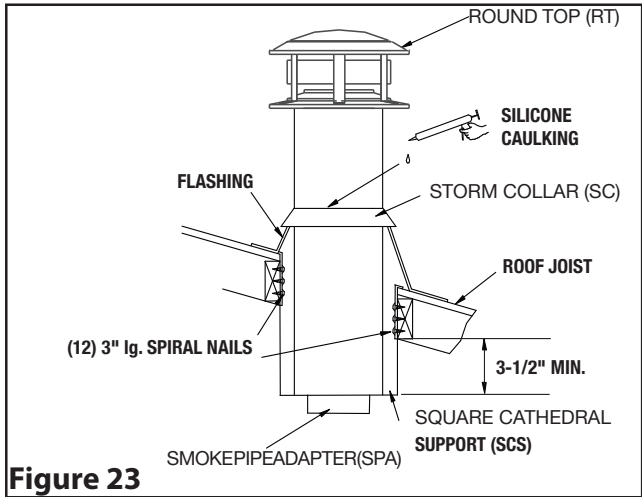

Figure 23

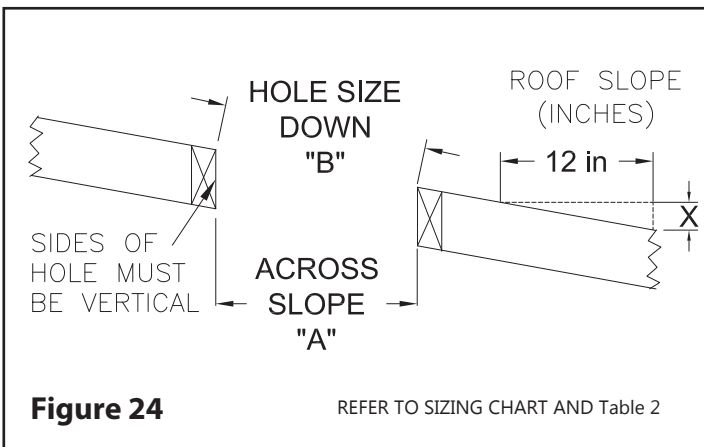

Figure 24

REFER TO SIZING CHART AND Table 2

5 OFFSET DEVIATION

OFFSET CHIMNEY

It may be necessary to offset the chimney to clear an obstruction such as a joist or truss, or to position the chimney close to the ridge cap. A maximum of two offsets (4 elbows in all) is allowed in a chimney. The chimney must not be inclined more than 30° from vertical (USA) and 45° (Canada Only).

The minimum chimney height when using 15° offsets is 10'.

The minimum chimney height when using 30° or 45° offsets is 15'.

The maximum length of unsupported offset chimney is 6'. If the offset chimney is longer than 6', then it must be supported at 6' intervals using the Universal Roof Support (URS) Refer to **Figure 21** for visual.

⚠ WARNING

A support must always be installed right above each offset (two elbows) to support the chimney above the offset.

INSTALLATION INSTRUCTIONS - OFFSET CHIMNEY

If you are venting a Factory built fireplace or an oil or gas burning appliance please refer to installation notes 2B and 2C (**Section 1**) for guidelines on the use of the Premium shields.

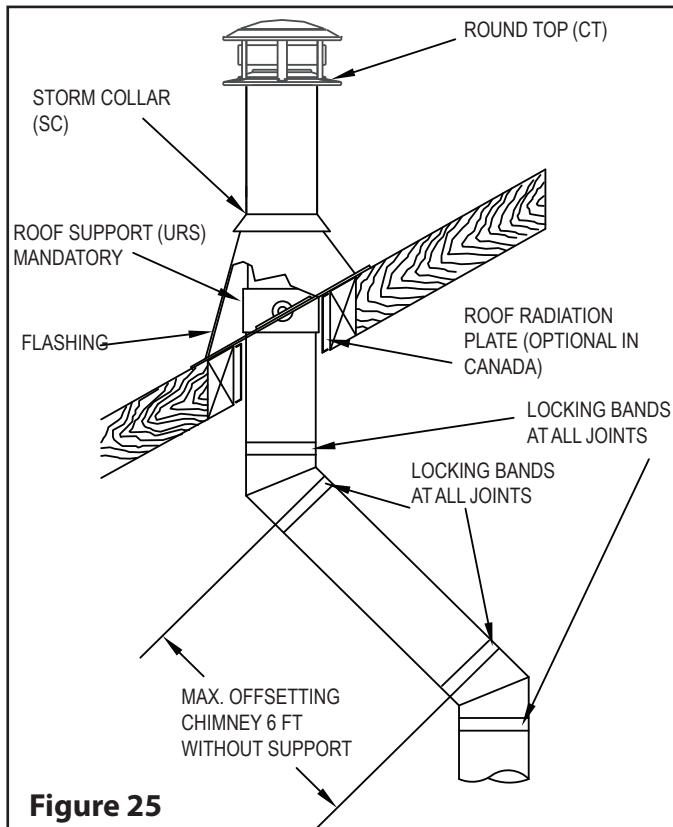

For Unenclosed installation or venting of oil or gas appliances: (CANADA & USA), or for Wood Burning Appliances installation (USA ONLY) (See Figure 25)

Step 1. Put the first chimney length in the support. Stack the next chimney length on the first length. To secure the joint of the Length section within the Flexible Length is, the ALTERNATE JOINT SECURING in section 1 should be used (with Screws). See **Figure 4**. When you reach the height at which the elbow will be install:

Step 2. Install the insulated off set elbow on the vertical chimney length. Turn it in the required direction and fasten it to the chimney with the (4)-1/2" metal screws provided.

Step 3. Place the required off set chimney length (see **Table 7**) on the elbow. Secure the Elbow with the Locking band or alternate Screws (Refer to **Section 1** at **JOINT ASSEMBLY** or **ALTERNATE SECURING**).

Step 4. Use another elbow to turn the chimney vertically. Secure the elbow to the chimney length using the (4)-1/2" metal screws provided. Install the remaining chimney as described in the instructions for the Interior Straight installation on Section 3.

Step 5. Install the remaining chimney as described in the instructions for the Roof Support (See **UNIVERSAL ROOF SUPPORT** in **Section 7**).

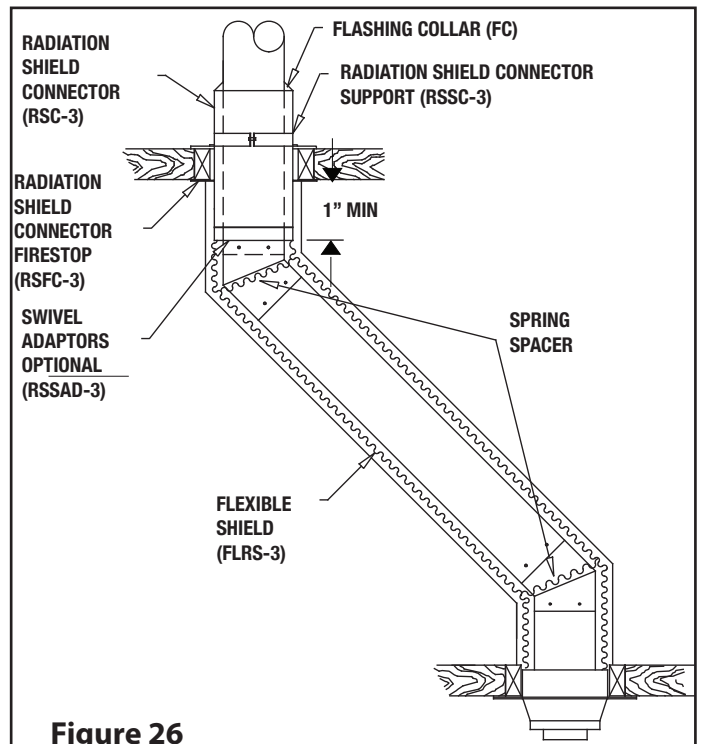

5 OFFSET DEVIATION (CONT'D)

(CANADA Only) For Interior Offset installation wood or coal burning appliance (6", 7", and 8" dia.). (See Figure 26)

- Step 1. Place the first chimney length on a flat surface with the male coupling on top.
- Step 2. Slide a Flexible Shield (FLRS-3) on top of that length all the way to the bottom.
- Step 3. Attach the flexible shield to the section using 3 x 1/2" stainless steel self tapping screws.
- Step 4. Slide this assembly in the support and turn clockwise to lock it in place.
- Step 5. At the ceiling level from below, position a Radiation Shield Connector Firestop (RSFC-3) (See **Figure 27A**).
- Step 6. At the ceiling level from the top, position a Radiation Shield Connector (RSC-3) and a Radiation Shield Support (RSSC-3) attached but not tightened together (see **Figure 27A**).
- Step 7. Slide the Radiation Shield Connector down until the bottom of the insulated tube exceed the bottom of ceiling. Adjust the height until a minimum of (1") of the Radiation Shield Connector project below the ceiling and tighten the support collar around the shield connector (see **Figure 26**)

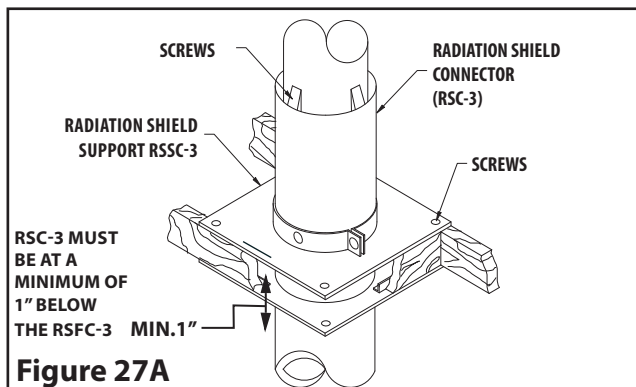

- Step 8. Stack the next chimney length on the first length. To secure the joint of the sections, please refer to the JOINT ASSEMBLY or ALTERNATE JOINT SECURING in **Section 1**. See **Figure 4**. You may add a 1/2 in stainless steel self tapping screw to prevent accidental unlocking. When you reach the height at which the elbow will be installed:
- Step 9. Install the insulated offset elbow on the vertical chimney length. Turn it in the required direction and fasten it to the chimney with the (4)-1/2" metal screws provided.

- Step 10. Place the required offset chimney length (see Table 7) on the elbow. Secure the joint of the section.
- Step 11. Use another elbow to turn the chimney vertically. Again secure the elbow to the chimney length using the (4)-1/2" metal screws.
 - Attach a spacer spring around the chimney at each elbow to help keep the Flexible Shield centered. (See **Figure 26**)
- Step 12. From the attic, feed the subsequent pipe Lengths through the Radiation Shield Connector (RSC-3) down to the top elbow.
- Step 13. To secure the joint of the pipe section on the Elbow, need to go back in the room. Then refer to the JOINT ASSEMBLY or ALTERNATE JOINT SECURING in **Section 1**.
- Step 14. Slide the Flexible Shield up the chimney and attach it below the ceiling to the Radiation Shield Connector using (3) - 1/2" self tapping metal screws.

NOTE: If additional shield length is needed, two or more flex shields can be connected, or by using an additional Swivel Adaptor RSSAD-3 between both Flexible Shield FLRS-3.

NOTE: If you are limited in space to be able to fix the screws that fix the flex to the Radiation Shield Connector, install a Swivel Adaptor (RSSAD-3) (see **Figure 26**) below the Shield Connector (RSC-3) and one on the top end of the Flexible Shield.

- Step 15. **In the attic** Fix the Radiation Shield Connector (RSC-3) to the chimney.
- Step 16. A storm Collar (included with RSC-3) must be install on top of Radiation Shield Connector (RSC-3) to prevent any loose insulation from falling in the area between the chimney and the support. (See **Figure 27B**)

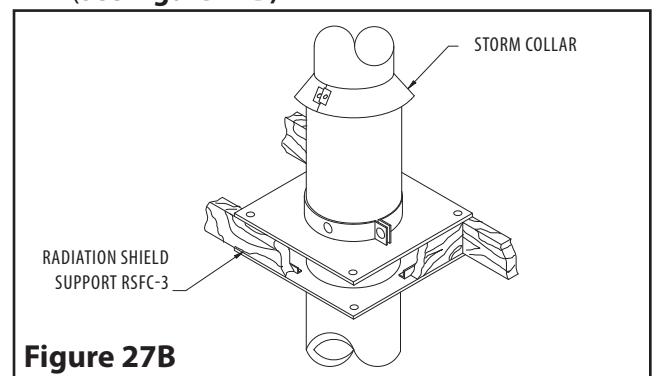

5 OFFSET DEVIATION (CONT'D)

INSTALLATION CALCULATIONS

Determine the offset required in view of the obstacles that must be avoided (see **Figure 28**). Refer to Table 7 to determine the elbows required as well as the insulated length needed. If required, an adjustable length can be used to offset exact distance required.

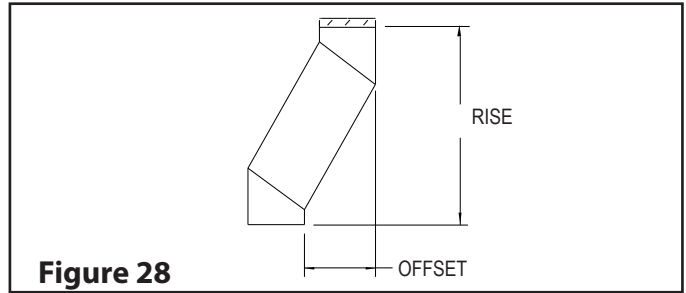

Figure 28

Table 7
15° ANGLE **OFFSET AND RISE CHARTS - MODEL ULTIMATEPLUS (6" - 8")**

DIA.	INCHES	ONE LENGTH BETWEEN ELBOWS							TWO LENGTHS BETWEEN ELBOWS						
		0	8	12	18	24	36	48	0	8 & 48	12 & 48	18 & 48	24 & 48	36 & 48	48 & 48
6"	Offset	1	2-5/8	3-3/4	5-1/4	6-3/4	9-7/8	13	1	14-5/8	15-3/4	17-1/4	18-7/8	21-7/8	25
	Rise	8-3/4	15	18-7/8	24-5/8	30-3/8	42	53-5/8	8-3/4	59-7/8	63-5/8	69-1/2	75-1/4	86-7/8	98-1/2
7"	Offset	1	2-5/8	3-3/4	5-1/4	6-3/4	9-7/8	13	1	14-5/8	15-3/4	17-1/4	18-7/8	21-7/8	25
	Rise	9-1/4	15-1/2	19-3/8	25-1/8	30-7/8	42-1/2	54-1/8	9-1/4	60-3/8	64-1/8	70	75-3/4	87-3/8	99
8"	Offset	1	2-5/8	3-3/4	5-1/4	6-3/4	9-7/8	13	1	14-5/8	15-3/4	17-1/4	18-7/8	21-7/8	25
	Rise	9-1/2	15-3/4	19-5/8	25-3/8	31-1/8	42-3/4	54-3/8	9-1/2	60-5/8	64-3/8	70-1/4	76	87-5/8	99-1/4

30° ANGLE

DIA.	INCHES	ONE LENGTH BETWEEN ELBOWS							TWO LENGTHS BETWEEN ELBOWS						
		0	8	12	18	24	36	48	0	8 & 48	12 & 48	18 & 48	24 & 48	36 & 48	48 & 48
6"	Offset	2-1/4	5-1/2	7-1/2	10-1/2	13-1/2	19-1/2	25-1/2	2-1/4	28-5/8	30-5/8	33-3/4	36-5/8	42-5/8	48-5/8
	Rise	10-1/2	16-1/8	19-1/2	24-3/4	29-7/8	40-3/8	50-3/4	10-1/2	56-1/4	59-3/4	65	70-1/8	80-1/2	90-7/8
7"	Offset	2-1/2	5-3/4	7-3/4	10-3/4	13-3/4	19-3/4	25-3/4	2-1/2	28-7/8	30-7/8	34	36-7/8	42-7/8	48-7/8
	Rise	11	16-5/8	20	25-1/4	30-3/8	40-7/8	51-1/4	11	56-3/4	60-1/4	65-1/2	70-5/8	81	91-3/8
8"	Offset	2-3/4	6	8	11	14	20	26	2-3/4	29-1/8	31-1/8	34-1/4	37-1/8	43-1/8	49-1/8
	Rise	11-1/2	17-1/8	20-1/2	25-3/4	30-7/8	41-3/8	51-3/4	11-1/2	57-1/4	60-3/4	66	71-1/8	81-1/2	91-7/8

45° ANGLE (Canada Only)

DIA.	INCHES	ONE LENGTH BETWEEN ELBOWS							TWO LENGTHS BETWEEN ELBOWS						
		0	8	12	18	24	36	48	0	8 & 48	12 & 48	18 & 48	24 & 48	36 & 48	48 & 48
6"	Offset	4	8-1/2	11-3/8	15-5/8	19-7/8	28-3/8	36-7/8	4	41-3/8	44-1/4	48-1/2	52-3/4	61-1/8	69-5/8
	Rise	11-3/4	16-1/4	1-1/8	23-3/8	27-5/8	36-1/8	44-5/8	11-3/4	49-1/8	52	56-1/4	60-1/2	68-7/8	77-3/8
7"	Offset	4-1/2	9	11-7/8	16-1/8	20-3/8	28-7/8	37-3/8	4-1/2	41-7/8	44-3/4	49	53-1/4	61-5/8	70-1/8
	Rise	12-3/4	17-1/4	20-1/8	24-3/8	28-5/8	37-1/8	45-5/8	12-3/4	50-1/8	53	57-1/4	61-1/2	59-7/8	78-3/8
8"	Offset	4-3/4	9-1/4	12-1/8	16-3/8	20-5/8	29-1/8	37-5/8	4-3/4	42-1/8	45	49-1/4	53-1/2	61-7/8	70-3/8
	Rise	13-3/4	18-1/4	21-1/8	25-3/8	29-5/8	38-1/8	46-5/8	13-3/4	51-1/8	54	58-1/4	62-1/2	70-7/8	79-3/8

Note: All dimensions are in inches.

NOTE: DIAGRAMS & ILLUSTRATIONS ARE NOT TO SCALE.

5 OFFSET DEVIATION (CONT'D)

ADJUSTABLE LENGTH (AL)

If required, an Adjustable Length is installed between other components or offset to establish an exact finished length, where a standard length can not be used.

INSTALLATION INSTRUCTIONS

Step 1: Slide the Adjustable Length over the preceding length until the desired length is achieved. The Adjustable Length must overlap by at least 3" (**Figure 29A**).

NOTE: To slide easily, it may be necessary to remove excess insulation: remove the insulation from the length; cut the insulation to the desired length and insert back into the length. The insulation must completely fill the cavity.

Step 2: Secure the Adjustable Length to the preceding section using the three (3) metal screws supplied.

Step 3: In order to prevent overloading the Adjustable Length, install a support UWS or URS) within the next 5' (60") following the Adjustable Length

Figure 29B

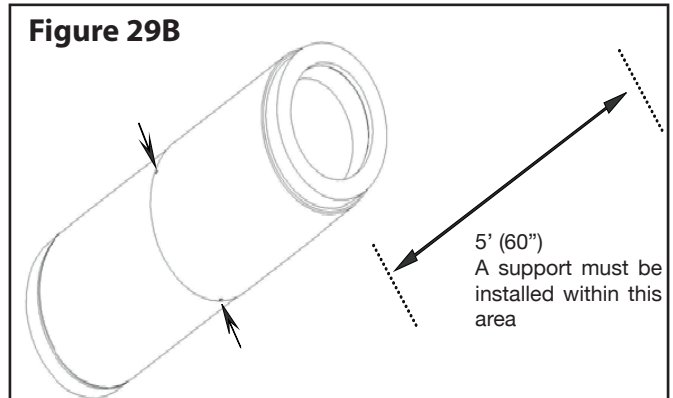
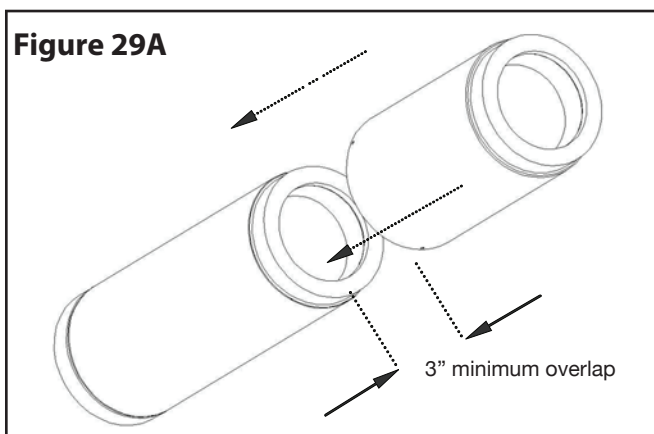

Figure 29A



5 OFFSET DEVIATION (CONT'D)

UNIVERSAL ROOF SUPPORT (URS)

- It may be used to support a chimney from the roof. It adjusts to any roof pitch.
- It may be used on a floor, ceiling or roof above an offset to support the chimney above the offset.
- It may be used on a floor, ceiling or roof as a supplementary support when the chimney height exceeds that of the primary support. See Maximum Support Height in **Table 1**.

Never use makeshift compromises during the installation of the Universal Roof Support.

CAUTION: MAKESHIFT INSTALLATION ON ROOF ASSEMBLIES CAN CAUSE A HAZARDOUS ENVIRONMENT.

INSTALLATION INSTRUCTIONS

Refer to **Table 1** for the maximum chimney height the Roof Support will support. If greater height is required use additional Roof Support at intervals not exceeding 30 feet.

NOTE: The Universal Roof Support can also be used as an Offset Support.

Refer to **Table 8, Figures A & B** on **Section 6** for more information.

With the chimney extending through the opening in the roof, ceiling or floor proceed as follows (Refer to **Figures 30 & 31** for visual references):

- Step 1. (**US only**) Install the roof radiation shields in the roof frame opening. These shields consist of four metal plates. Nail these plates to each side of the Opening using (2) - 2 1/2" nails. See **Figure 23**.
- Step 2. Assemble the Roof Support's Collar to fit your chimney diameter. Continue to assemble the support as described on **Section 6**.
- Step 3. Slip the assembled Roof Support down over the stainless steel chimney until its brackets rest on the roof or floor. Tighten the collar around the chimney.
- Step 4. Center the chimney and nail or screw the support to the roof or floor using (8) - 2-1/2" nails or (8) #8 - 1-1/4" wood screws (see **Figure 30**).
- Step 5. Install the remaining chimney lengths, until the required chimney height is reached.

See **Figures A & B** on **Section 6** for more information.

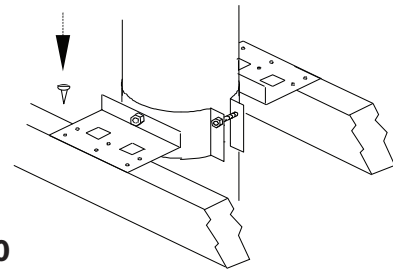

Figure 30

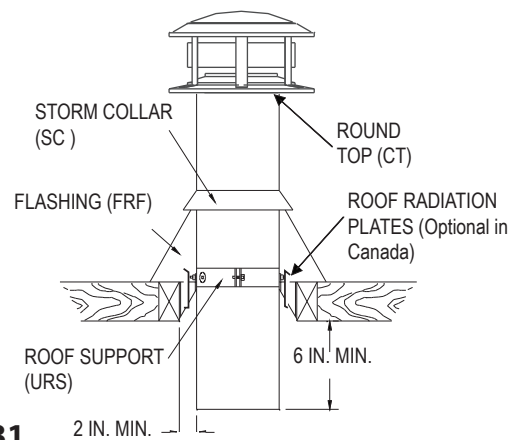

Figure 31

Step 6. **ROOF FLASHING INSTALLATION**

Put the roof flashing in place. Seal the joint between the roof and the flashing with roofing compound. For sloping roofs, place the flashing under the upper shingles and on top of the lower shingles. Nail the flashing to the roof using nails. Place the storm collar around the chimney and slide down on top of the flashing. Tighten it with the bolt supplied making sure the joint is properly caulked (see **Figure 19**).

ATTENTION! Do not block the space between the flashing and the chimney. It is required to be fully open for the purpose of ventilation.

Step 7. Refer to **Section 1** for the Round Top installation. This chimney will provide optimum performance when installed within the heated space of a building. The consequences of installing the

6

ASSEMBLY OF THE UNIVERSAL COLLAR - URS, UWS, UWB, URBK

The following pages will assist in the assembly of the Universal Roof Support, Wall Support, Wall Band and Roof Brace Kit. All have the same Universal Collar. See **Table 8 & Fig. A** below for proper hole alignment for UltimatePlus 6" to 8" diameters.

TABLE 8

CHIMNEY MODEL	DIA	HOLE ALIGNMENT FOR UNIVERSAL COLLAR	SLIDING LEG ADJUSTMENT
UltimatePlus	6"	C-C	MAINTAIN THE MINIMUM AIR SPACE CLEARANCE OF 2" TO ALL COMBUSTIBLES
	7"	B-B	
	8"	A-A	

Universal Collar Fig. A

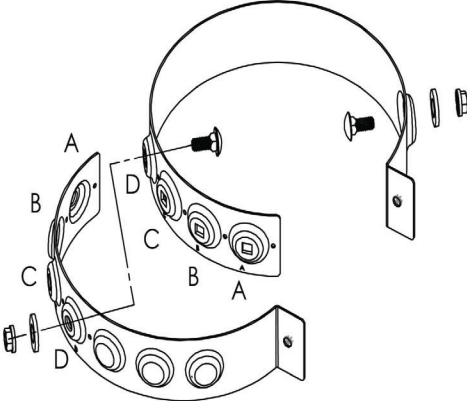

Universal Collar

1. Assemble the two (2) portions of the Universal Collar with the hole alignment found in Table 8 above. Use the supplied carriage bolt, washer and nut as per Fig. A.
2. Join the two (2) portions with the supplied nut and bolt. Do not tighten at this time.
3. Select which component the Universal Collar will serve. Go to these instructions.

Universal Roof Support (URS)

Refer to **Table 1** for the maximum chimney height the Roof Support will support. If greater height is required use additional Roof Support at intervals not exceeding 30 feet.

NOTE: The Universal Roof Support can also be used as an Offset Support.

1. Assemble the two (2) portions of the Universal Collar as described above under Universal Collar and **Fig. A**.
2. Attach the roof brackets to the Collar as per **Fig. B**.
3. Slip the assembled Roof Support down over the chimney length until the brackets rest on the roof or floor. Tighten the collar around the chimney. **Fig. B** Universal Roof Support

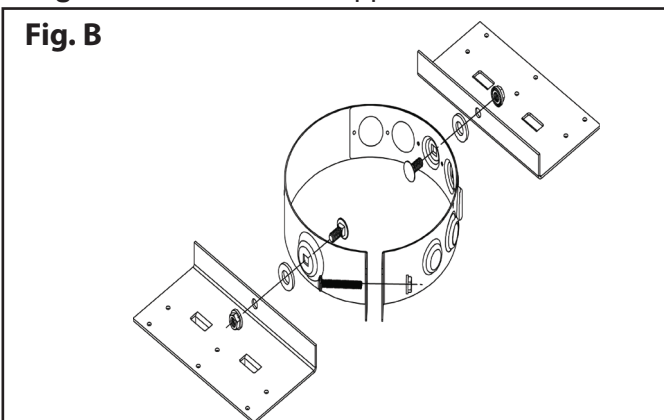

4. Center the chimney and maintain the required 2" air space clearance to combustible materials. Secure the support to the roof or floor using (8) - 2-1/2" nails or (8) #8 - 1-1/4" wood screws. Refer to **Figures 30 & 31** for more information.

Universal Wall Support (UWS)

Refer to **Table 1** for the maximum chimney height the Wall Support will support. If greater height is required use additional Wall Support at intervals not exceeding 30 feet.

NOTE: The Wall Support can also be used as an Offset Support.

Assemble the two (2) portions of the Universal Collar as described above under the Universal Collar and **Table 8** and **Fig. A**.

Attach the wall brackets to the Collar as per **Fig. C**.

Slip the support down over the first vertical chimney length to the proper location.

Tighten the collar around the chimney. Attach the support brackets to the wall using (8) 3" nails or (8) #10 x 1-1/4" wood screws.

For more information, refer to **Figure 26**.

6

ASSEMBLY OF THE UNIVERSAL COLLAR (CON'T)

Fig. C

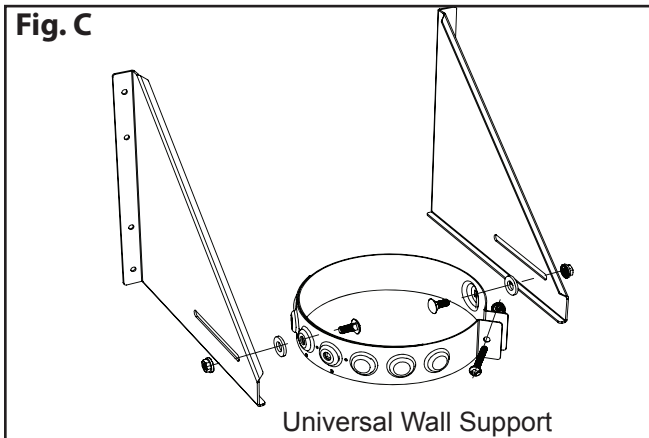

Universal Wall Support

Universal Wall Band (UWB)

1. Assemble the two (2) portions of the Universal Collar as described under the Universal Collar, **Fig. A and Table 8**.
2. Assemble the 2 sliding legs together with the supplied nut and bolt (2 per legs) as per **Fig. D**.
3. Attach the 2 sliding legs to the Collar as per **Fig. E**.
4. Place the Universal Wall Band on a vertical chimney length to the selected location.
5. Secure the Universal Wall Band to the wall using two (2) #10 x 1-1/4" wood screws or appropriate fasteners.

Maintain the minimum air space clearance of 2" from the outer chimney to the wall.

The Universal Wall Band must be used at 8' intervals and attached to a framing construction and not merely to the siding.

Fig. D

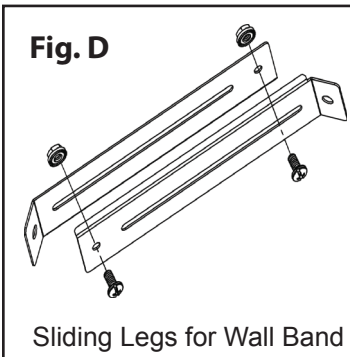

Sliding Legs for Wall Band

Fig. E

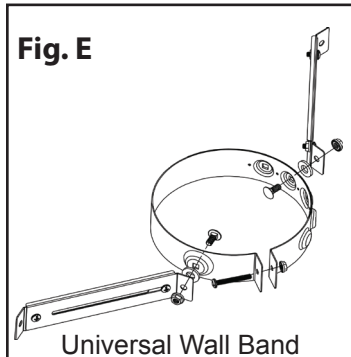

Universal Wall Band

Universal Roof Brace Kit (URBK)

The preferred location is next to a joint, immediately above or below. Only one chimney joint should be above the collar of the Roof Brace Kit.

1. Assemble the two (2) portions of the Universal Collar as describe under the Universal Collar and **Fig. A and Table 8**.
2. Secure one end of each adjustable leg to the Universal Collar as per **Fig. F**.
3. Attach the other end of the adjustable leg to the roof bracket as per **Fig. F**.
4. Position the adjustable legs so they form approximately a 60° angle with the chimney, and with each other. Make sure there is at least 3" of overlap between the top and bottom halves of the adjustable leg before securing in its final position with the eye bolt screw.
5. Determine the location of the two roof brackets on the roof structure. Ensure the fasteners are into rafters or framing and not just the roof sheathing.
6. Secure the roof brackets to the roof structure using two (2) 1/4" x 2" lag screws per brackets. Apply a thin layer of caulking under the roof brackets as well as over the lag screws.

Fig. F

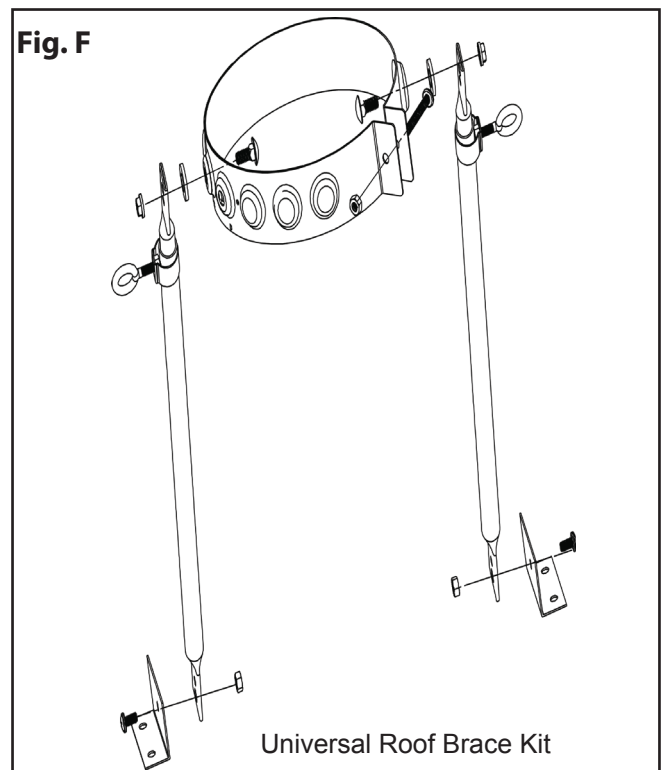

Universal Roof Brace Kit

7

EXTERIOR INSTALLATION (CONT'D)

GENERAL EXTERIOR INSTALLATION NOTES

This chimney will provide optimum performance when installed within the heated space of a building. The consequences of installing the chimney outdoors, up the exterior wall of a building could result in:

- Back-drafting during cold weather when the connected appliance is not operating.
- Weak, unstable draft.
- Increased creosote accumulation
- Increased potential for condensation of water vapor in the chimney flue decreased efficiency of the connected appliance.

If you do install an exterior chimney, we recommend that you enclose it using an insulated enclosure.

EXTERIOR INSTALLATION NOTES

1. The chimney may be enclosed or unenclosed.

CANADA Only:

Premium Shield are not required for exterior installation. If the chimney is to be enclosed in a chase, maintaining at least 3" clearances to combustible allow the chimney to be enclosed without the need of the Premium Shield accessories. The Wall Support and Universal Wall Band (UWB) will need to be adjusted to 3" clearance from vertical exterior wall.

2. If the chimney is to be unenclosed, maintain 2" clearance to combustible materials.
3. A Universal Wall Band (UWB) or a Universal Wall Support (UWS) must be used to secure the chimney to the wall when used on an unenclosed exterior wall. Maximum distance between wall bands is 8'.
4. The horizontal chimney length passing through the wall must project a minimum of 5" and no more than 24" beyond the inside wall. Minimum projection is required to ensure appropriate clearances are maintained to stovepipe.
5. If an exterior installation is to be enclosed, allow for access to base of tee to facilitate required inspection and cleaning.
6. The minimum distance between the bottom of the Tee or Support and any horizontal combustible is 2" by using an Insulated Tee Cap (ITC).

UNIVERSAL WALL SUPPORT(UWS)

When a chimney is used along a wall, the Universal Wall Support UWS may be used to support the chimney. The height of the supported chimney with a UWS is shown in **Table 1**.

If greater height is required use an additional Wall Support at intervals not exceeding 30 feet.

NOTE: The UWS can also be used as an Offset Support.

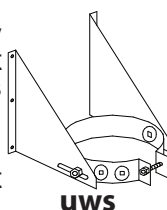

INSTALLATION INSTRUCTIONS

Step 1. Refer to **Table 8, Figures A and C** for more information. Refer to **Figure 32** as visual reference.

Step 2. Slip the support down over the chimney to the proper location. Tighten the collar around the chimney.

Step 3. Attach the support brackets to the wall using (8) 3" nails or (8) N^o. 10 x 1-1/4" wood screws.

Step 4. At 8' intervals, secure the chimney to the wall by using a Universal Wall Band (UWB) or Universal Wall Support (UWS).

NOTE: Be sure that the support attaches to a solid structure and not merely to the siding.

Step 5. If the chimney passes through the roof, cut a hole large enough to provide 2" clearance between the chimney and the roof. For pitch roof, see Roof Opening Chart - **Table 2**.

To continue, see Steps 6 through 10 on **Section 2**.

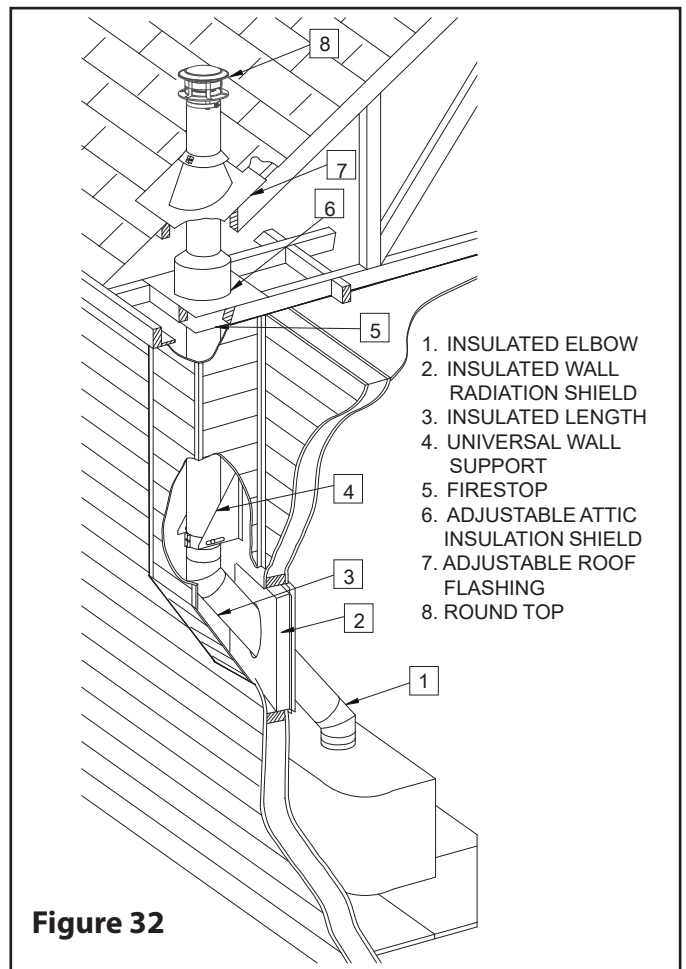

Figure 32

7

EXTERIOR INSTALLATION (CONT'D)

WALL SUPPORT (UWS, AIWS, BTWS)

See different types of Wall Support on **Figure 33**.

INSTALLATION INSTRUCTIONS

Step 1. Determine where the chimney will pass through the wall.

For concrete walls cut an opening as per **Table 9** below.

For combustible walls cut and frame a hole, midway between the wall studs (see **Table 9** below for sizing).

Normally wall studs are placed at 16" on center. With the hole midway between them, the support will fasten to these studs and thus ensure a strong attachment to the wall (see **Figure 34**).

Step 2. Wood walls: Place the exterior half of the Insulated Wall Thimble (IWT) in the opening from the outside. Nail in place using (4) 2" nails or 1" screws. This Wall Thimble is adjustable from 7" to 12" (see **Figure 35**). Make sure the insulation pad is cut to the desired length according to the wall thickness. Place the interior half of the Wall Thimble inside the exterior half of the Wall Thimble. For a wall requiring more than 12", a shield extension can be field fabricated using galvanized sheet metal 26 gauge minimum.

Ensure the opening for the chimney to pass through is straight and level. Screw the inner thimble in place with the provided screws (see **Figure 36**).

NOTE: The cavity surrounding the wall thimble metal shield can be filled with insulation (see **Figure 36**).

CHIMNEY SIZE	OPENING SIZE	
	COMBUSTIBLE	CONCRETE
6"	12" x 12"	8-3/4"
7"	13-3/8" x 13-3/8"	9-3/4"
8"	14-3/8" x 14-3/8"	10-3/4"

Table 9

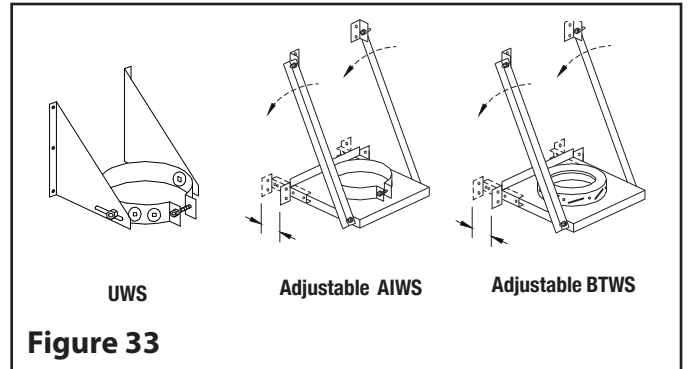

Figure 33

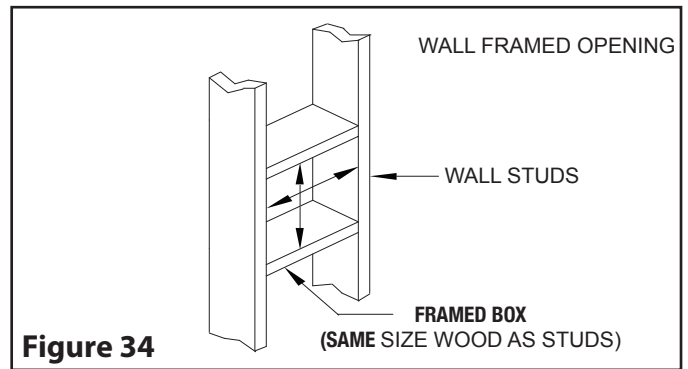

Figure 34

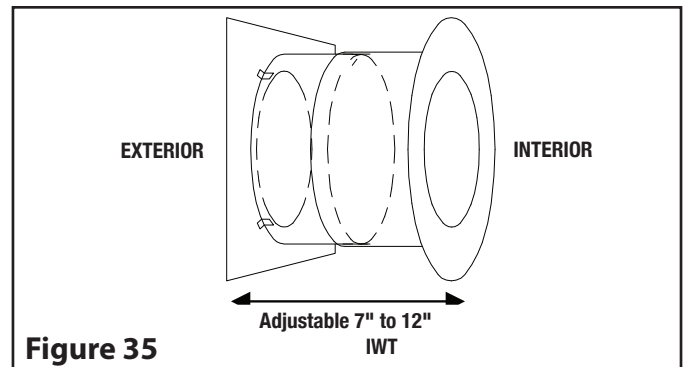

Figure 35

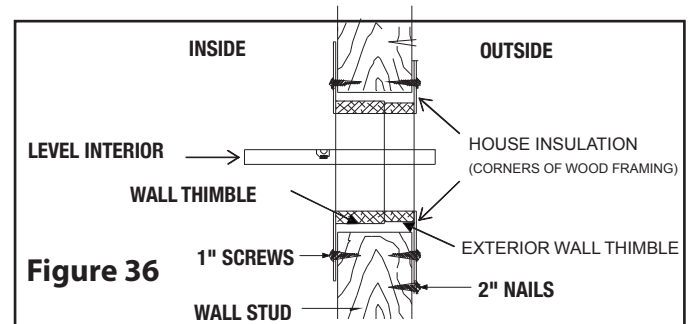

Figure 36

Step 3. The minimum length of insulated chimney required to pass through the wall will be thickness plus 7". The insulated chimney must extend at least 5" into the room beyond the finished wall. Insert this chimney length in the side branch of the insulated tee until fully seated. Install the Locking Band as per instructions on **Section 1** and **Figure 3** for securing the joint at the Tee Branch. Make sure the securing latch is facing down to prevent any water from collecting in the Locking Band. It is recommended to use a silicone sealant on the head of the top screw. Mount the insulated tee on the support so that the chimney length which will go through the wall is perpendicular to the side of the support that will fasten to the wall. Secure the tee to the base of the support using four (4) - #8 x 3/4" A/ AB screws (supplied).

NOTE: If a joint is to be located within the Wall Thimble, you will need to substitute the Locking Band with 4 sheet metal screws instead (refer to **Figure 4**).

NOTE: The supports (UWS or AIWS) can be installed above the Tee. See **Figure 39**.

Step 4. This step will require 2 people: (see **Figure 37**). Insert the chimney length of this tee-support assembly into the hole in the wall. Using a level, ensure the tee is vertical, then attach the support to the wall using (8) N°. 10 x 1 - 1/4" wood screws or 4" spiral nails.

NOTE: To provide sufficient strength, the nails must be driven into the wall studs. For concrete walls, the support should be attached using (8) 1/4" x 2" lag bolts.

Step 5. Attach the clean-out cap to the Tee Support or Tee.

Step 6. Attach the Smoke Pipe Adapter to the horizontal chimney length. See **Section 1** under Smoke Pipe Adapter for more information.

Step 7. Stack a chimney length on top of the Tee until fully seated. Install a Locking Band to secure the joint (see **Section 1**). Continue until the required chimney height is reached.

FOR UNENCLOSED INSTALLATION:

Step 8. At 8' intervals, secure the chimney to the wall using a Universal Wall band or Universal Wall Support. If the chimney passes through the roof, cut a hole large enough to provide 2" clearance between the chimney and the roof. For pitch roof, See roof opening **chart on table 2 (See FIGURE 38)**

To continue, go to STEP 8. on Section 2: INSULATED REDUCED SUPPORT (IRCS).

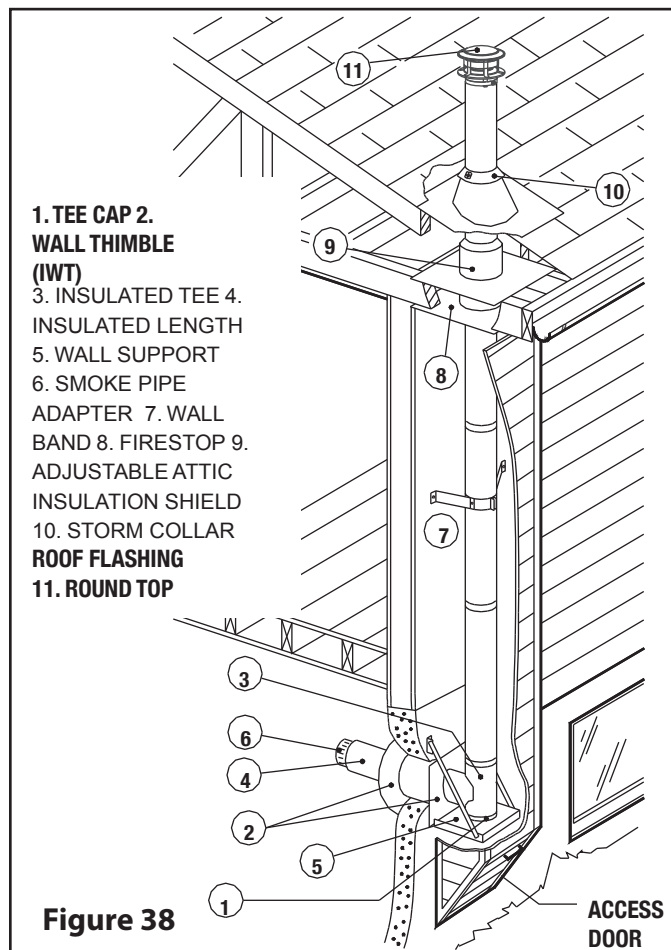
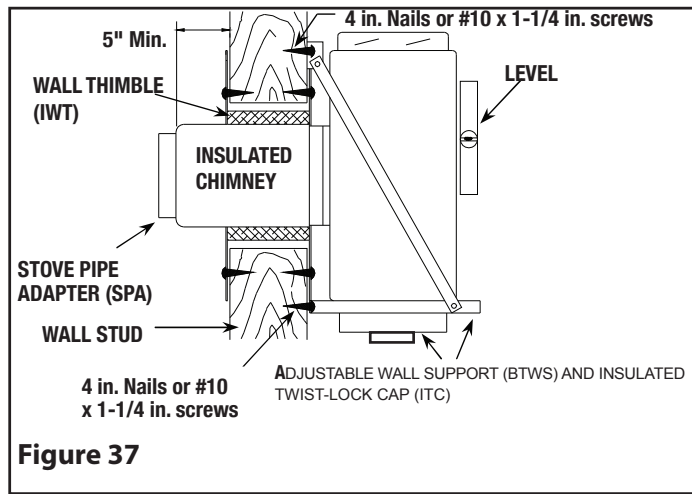

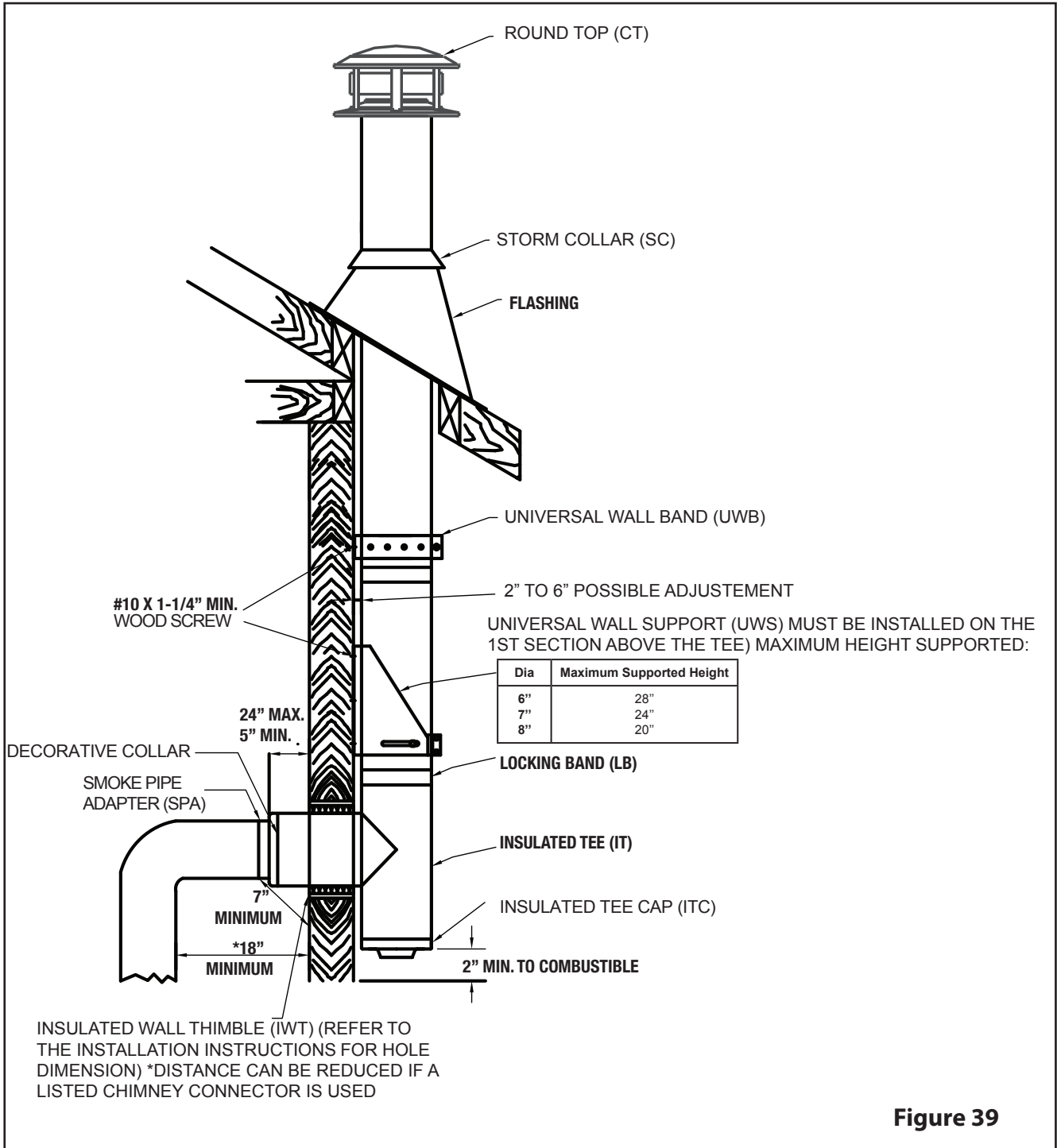

Figure 39

NOTE: An optional black Decorator Sleeve is available to cover the stainless steel chimney length extending through a wall into the room. Can be used with a non combustilbe wall or in conjunction with the Wall Thimble by simply sliding the Decorator Sleeve over the length. An optional Trim Collar is also available.

8

INTERIOR INSTALLATION ON A FURNACE, BOILER, OR WATER HEATER

Step 1. Locate the chimney in a convenient place as near as possible to the appliance outlet. Cut and frame the opening in the ceiling where the chimney will pass.

NOTE: It is important to follow the framing dimensions for the floor openings prescribed in this manual.

Refer to Table 1 for proper framing dimensions.

Step 2. From below push the support into the framed hole. Nail the support to the framed box using (12) 3" spiral nails or #8 x 1 1/2" wood screws (see **Figure 40**).

Step 3. Before installing the first length into the support, install the Smoke Pipe Adapter (**Section 1**). Lower length into the support, making sure the Smoke Pipe Adapter protrudes through the opening of the support.

NOTE: Arrow on pipe label must be pointing up.

Step 4. From below, install a Firestop (FS or FRS10) in each floor through which the chimney passes (see **Figure 41**).

Step 5. Stack the next chimney length on the first length. Make sure it is fully seated. Install a Locking Band to secure the joint (See **Section 1**). Continue until the required chimney height is reached.

Step 6. At the attic level, install a Firestop (FS), from below add an Adjustable Attic Insulation Shield (AAIS) from above (see **Figure 42**).

Step 7. (**OPTIONAL IN CANADA**) Install the roof radiation shields in the roof frame opening. These shields consist of four metal plates. Nail one plate to each side of the joist using (2) 2-1/2" nails.

Step 8. Put the roof flashing in place. Seal the joint between the roof and the flashing with roofing compound.

For sloping roofs, place the flashing under the upper shingles and on top of the lower shingles. Nail the flashing to the roof using roofing nails.

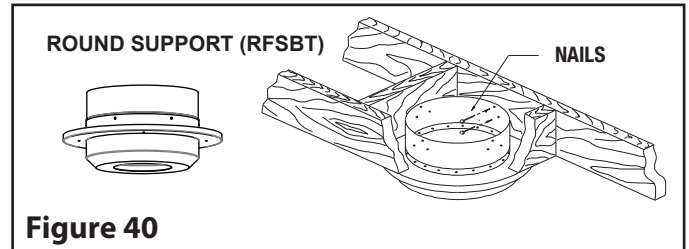

Figure 40

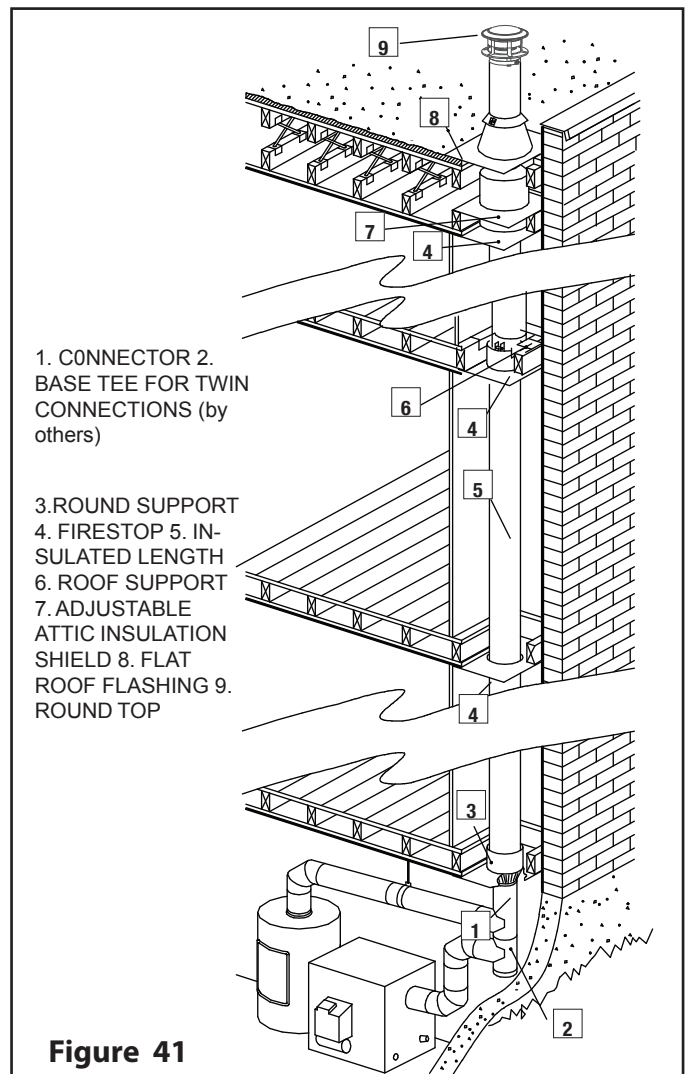
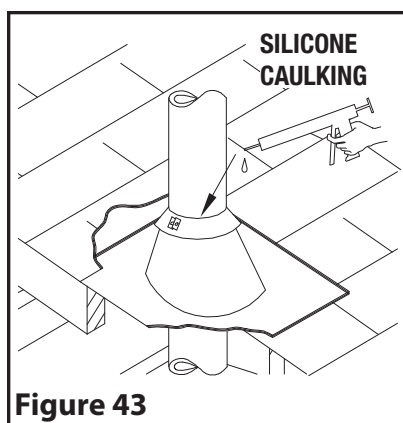
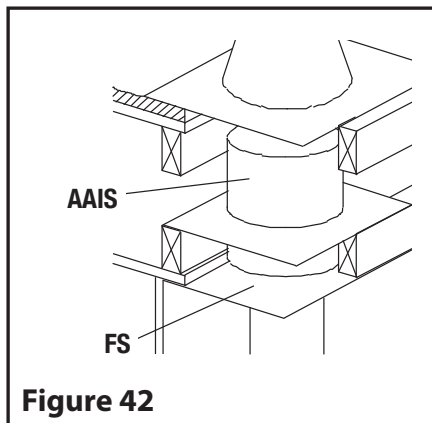

Figure 41

Step 9. Place the storm collar over the chimney and the flashing. Tighten it with the bolt supplied making sure the joint is properly caulked (see **Figure 43**).

Step 10: Attach the Round Top (CT) to the chimney. See **Section 1**.

ATTENTION! Do not block the space between the flashing and the chimney. It is required to be fully open for the purpose of ventilation.



9

SPECIALIZED COMPONENTS

ANCHOR PLATE (AP)

The Anchor Plate (AP) is used on a factory-built fireplace, on a masonry fireplace or on top of a furnace to provide a positive connection to the chimney. It is not to be used in contact with any combustible material, such as on a wood floor.

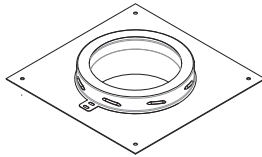

For factory-built fireplaces, follow the installation instructions supplied with the certified factory-built fireplace for any specification regarding the chimney.

Once the appliance is installed, bolt the Anchor Plate (AP) to the appliance using appropriate fasteners. See **Figure 44**. Secure the first section of chimney to the AP using the 4 supplied sheet metal screws.

NOTE: To make sure that the coupler of the Anchor Plate is not spinning on its axis, screw the tab at the position needed.

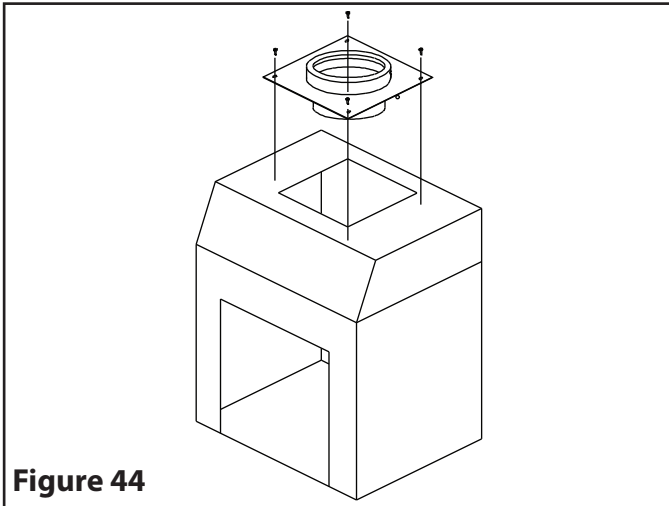

Figure 44

FLOOR SUPPORT PLATE (FSP)

The Floor Support Plate (FSP) may be required as a secondary support if the chimney exceed the primary support. Refer to **Table 1** for support capacity and framing dimension.

Install Floor Support Plate on top of the prepared surface and secure with appropriate fasteners. Position collar around the pipe so that the final position is on the plate. Tighten nut and bolt and secure with the supplied screws.

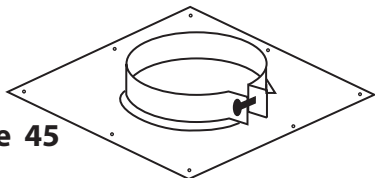

Figure 45

INSULATED WALL SHIELD 30° or 45° (Canada Only)

These are used only with wood-burning fireplaces which have been certified for use with UltimatePlus chimney system.

ANGLED INSULATED RADIATION SHIELD (WRIS30/WRIS45) have been designed for use when UltimatePlus is connected to a certified factory-built fireplace which passes through a wall at an angle (see **Figure 46** and **Table 10**).

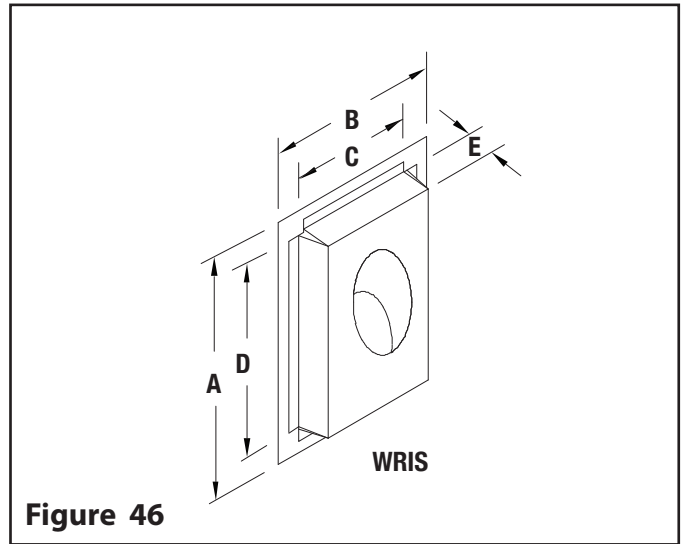

Figure 46

DIM.	SIZE					
	WRIS30			WRIS45 (CANADA ONLY)		
	6"	7"	8"	6"	7"	8"
A	34-3/4	37-3/4	39-3/4	24-5/8	26-5/8	28
B	15-5/8	16-5/8	17-5/8	15-5/8	16-5/8	17-5/8
C	11-3/8	12-5/8	13-3/8	11-1/8	12-1/8	13-1/2
D	30-3/4	33-3/4	35-3/4	20-3/8	22-1/8	23-1/2
E	3	3	3	3	3	3

Table 10 - Refer to Figure 46

INSULATED PASS-THROUGH RADIATION SHIELD (IPTS)

- The Insulated Pass-Through Radiation Shield is used when the insulated chimney passes up through a ceiling opening from below an attic space. Suited for flat, vaulted, cathedral ceiling or multi story applications.

- Extension adjust from 24 to 46 inches
- Opening at bottom of box acts as a firestop
- 12 inch insulation pad
- Square to round collar serves as an Attic Insulation Shield where required.

IMPORTANT: The 2" space surrounding the chimney must be filled only with the insulation provided. Using other insulation or materials could cause adjacent combustibles to overheat.

INSTALLATION INSTRUCTIONS

Step 1. Cut and frame the opening in the ceiling as per the dimensions in Table 11 and **Figure 49**.

Step 2. Determine the length of radiation shield required.

Step 3. Before installing, fix the extension to the shield, using the eight metal screws provided. Be sure there is at minimum overlap of 2" at the extension joint.

Step 4. Secure the Radiation Shield assembly to the ceiling using (12) x #8 x 1-1/2" wood screws or nails (not provided). If the Radiation Shield extends above the angled roof, cut flush with the top of the roof, or slit the corners of the box, folding each side down over the roof.

Step 5. Slide the insulated chimney through the shield until it reaches the length below. Make sure the joint is fully seated and install a Locking Band. Note: Locking Band will not fit through the opening at the bottom of the box. See page 8 for alternate joint securing method.

Step 6. Roll the 12" insulation pad around the chimney and push it (without compressing it) to the bottom of the Radiation Shield.

Step 7. If the Radiation Shield ends within the attic, install the square-to-round collar over the top of the Radiation Shield box as shown. This will prevent loose household insulation or other debris from falling within the shield.

Step 8. The vapor barrier can be attached to the radiation shield's perimeter using approved tape or sealant providing the minimum 2" air space clearance around the outside of the chimney is maintained.

Step 9. If desired, the gap between the outer layer of the chimney and the opening within the bottom of the shield can be sealed using high temperature rated (600°F) silicone caulking.

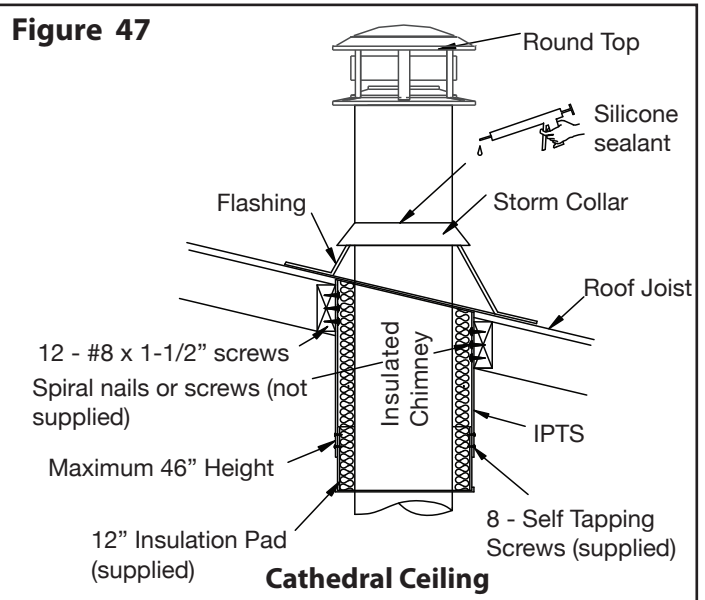
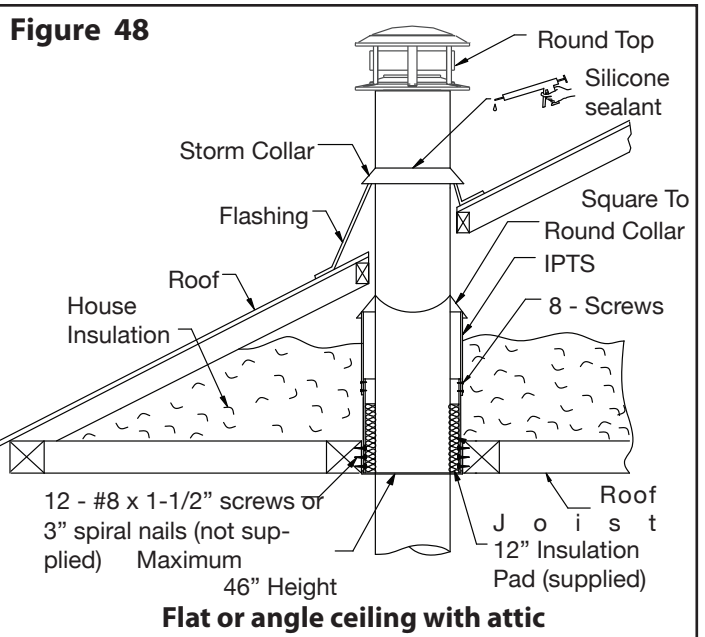
Figure 47**Figure 48**

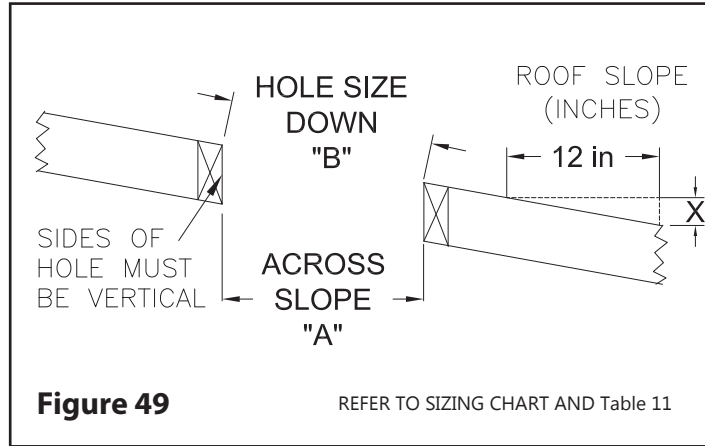

Figure 49

REFER TO SIZING CHART AND Table 11

Chimney Size	OPENING DIMENSION CHART FOR IPTS					
	6"		7"		8"	
Roof Slope (X/12)	Hole Size					
	A	B	A	B	A	B
0	12 1/8	12 1/8	13 1/8	13 1/8	14 1/8	14 1/8
2/12	12 1/8	12 1/4	13 1/8	13 1/4	14 1/8	14 3/8
4/12	12 1/8	12 3/4	13 1/8	13 7/8	14 1/8	14 7/8
6/12	12 1/8	13 1/2	13 1/8	14 5/8	14 1/8	15 3/4
8/12	12 1/8	14 5/8	13 1/8	15 3/4	14 1/8	17
10/12	12 1/8	15 3/4	13 1/8	17 1/8	14 1/8	18 3/8
12/12	12 1/8	17 1/8	13 1/8	18 1/2	14 1/8	20

Table 11

10

REPLACEMENT PARTS

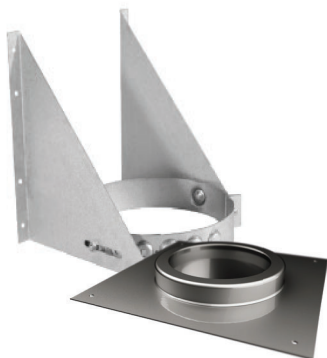

LENGTHS & ELBOWS	
L8-3	8" LENGTH
L12-3	12" LENGTH
L18-3	18" LENGTH
L24-3	24" LENGTH
L36-3	36" LENGTH
L48-3	48" LENGTH
AL12-3	12" ADJUSTABLE LENGTH
EL15-3	15 DEGREE ELBOW
EL30-3	30 DEGREE ELBOW
EL45-3	45 DEGREE ELBOW (CANADA ONLY)
SUPPORTS	
UWS	UNIVERSAL WALL SUPPORT
RS	ROOF SUPPORT
AP	ANCHOR PLATE
FSP	FLOOR SUPPORT PLATE
BRACES & FIRESTOPS	
FS	FIRESTOP
AFS30	ANGLED FIRESTOP - 30 DEGREE
AFS45	ANGLED FIRESTOP - 45 DEGREE
FRS	FIRESTOP RADIATION SHIELD
AAIS	ADJUSTABLE ATTIC INSULATED SHIELD
WRIS30	30° INSULATED WALL SHIELD
ITPS	INSULATED PASS-THROUGH SHIELD

10

REPLACEMENT PARTS CON'T

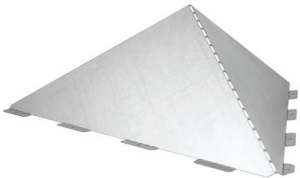

WRIS45	45° INSULATED WALL SHIELD (CANADA ONLY)
RBK	UNIVERSAL ROOF BRACE KIT
UWB	UNIVERSAL WALL BAND
GWB	GUY WIRE BAND (WIRE NOT INCLUDED)
VENTED FLASHING (STORM COLLAR INCLUDED)	
FRFR	FLAT ROOF FLASHING
ARF7R	ADJUSTABLE ROOF FLASHING 1/12 -7/12
ARF12R	ADJUSTABLE ROOF FLASHING 8/12 -12/12
ARF21R	ADJUSTABLE ROOF FLASHING 12/12 -21/12
SC	STORM COLLAR
USSA	UNIVERSAL SNOW SPLITTER
OTHERS	
CT	ROUNDTOP
USA	UNIVERSAL SPARK ARRESTER
ØTRLRS	TELESCOPIC RIGID LENGTH RADIATION SHIELD
ØFLRS	FLEXIBLE LENGTH RADIATION SHIELD
ØRSSC	RADIATION SHIELD SUPPORT CONNECTOR
ØRSFC	RADIATION SHIELD FIRESTOP CONNECTOR
ØRSC	RADIATION SHIELD CONNECTOR
ØRSSAD	RADIATION SHIELD SWIVEL ADAPTOR

To order a replacement part, reach out to your nearest dealer, distributor, or email us at:

- cscanada@selkirkcorp.com (Canada)

- info@selkirkcorp.com (USA),

- info@americanmetalproducts.com

INSTALLATION INFORMATION

Leave with homeowner. Homeowner: Keep in a safe place for future reference.

CHIMNEYMODEL: **ULTIMATEPLUS6-8**

FLUE SIZE: _____

TOTAL HEIGHT: _____

FUEL: _____

INSIDE INSTALLATION OUTSIDE INSTALLATION

CONNECTED TO (Type of appliance)

WOOD BURNING APPLIANCE

BOILER

FURNACE

LISTED FACTORY-BUILT FIREPLACE

OTHERS (Specify) _____

LOCATION OF APPLIANCE

BASEMENT

MAIN FLOOR

OTHER (Specify) _____

INSTALLATION DATE: _____

INSTALLATION ADDRESS: _____

DEALER INFORMATION

DEALER NAME: _____

ADDRESS: _____

CITY: _____

PROVINCE/STATE: _____

TECHNICIAN/INSTALLER INFORMATION

TECHNICIANNAME: _____

ADDRESS: _____

CITY: _____

PROVINCE/STATE: _____



Selkirk Corporation

4460 44th Street S.E., Suite F
Grand Rapids, MI 49512
Toll Free: 1.800.992.VENT (8368)
info@selkirkcorp.com
www.selkirkcorp.com



Selkirk Canada Inc

P.O. Box 526, Depot 1,
Hamilton, ON L8L 7X6
Toll Free: 1.888.SELKIRK (735.5475)
cscanada@selkirkcorp.com
www.selkirkcorp.ca



Hart & Cooley LLC

4460 44th Street S.E., Suite F
Grand Rapids, MI 49512
Toll Free: 1.800.423.4270
info@hartandcooley.com
www.ameri-vent.com

Manufacturer reserves the right to make changes at any time, without notice, in design, materials, specifications, prices.
Consult your local distributor for chimney system code information.