

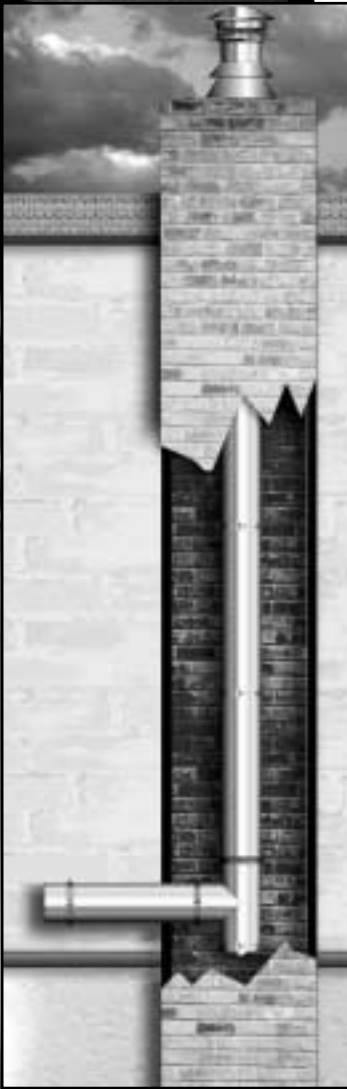

Model G Commercial/Industrial Single Wall Exhaust



Model G is a single wall negative, neutral, or positive pressure pre-fabricated piping system intended for use in a variety of applications including:

- *Fume Venting*
- *Chimney Liner*
- *Chutes*
- *Particle Conveying*
- *Grease Duct*
- *Dryer Vents*



Model G is Listed for grease duct and chimney liner applications

GENERAL USAGE

COMMON INSTALLATIONS 3

MODEL G

SINGLE WALL PIPE 4

ADJUSTABLE SINGLE WALL PIPE 4

SINGLE WALL FITTINGS 5

JOINT ASSEMBLY PARTS 7

SINGLE-WALL FITTINGS 7

SINGLE-WALL ACCESSORIES 8

SUPPORT/GUIDE ACCESSORIES 9

ROOF PENETRATIONS 10

TERMINATIONS 10

MODEL G

Model G is a single wall negative, neutral, or positive pressure capable, stainless steel pre-fabricated piping system for use in many applications including: grease duct, fume venting, chimney liner, chutes, particle conveying, etc. Model G is UL Listed for grease duct applications. Factory design assistance and submittals are available for Model G like all other Selkirk Metalbestos Commercial/Industrial products.

CORROSION RESISTANT

Standard Model G is available in type 304 stainless steel in 0.035" minimum thickness for sizes 6" through 36" I.D. and 0.048" minimum thickness for sizes 42" through 48" I.D. The type 316 alloy may also be specified for it's corrosion resistance to chemicals. Type 304 or 316 stainless steel is available in 0.048" minimum thickness in all sizes if so requested.

COMPONENT PARTS

Model G component parts are available in standard sizes 5" – 48", measured by diameter of the pipe. Parts are identified by individual part names and numbers. Each part name/number carries a diameter prefix size, the letter "G" designating Model G, followed by it's individual letter code, material type & length if required. See legend below for part number.

JOINT ASSEMBLY

For all Model G pipe and fittings, the flange-to-flange inner pipe joints are identical for each pipe I.D. Assembly of a typical joint is handled quickly and easily with regular maintenance crews and requires only standard hand tools and a Selkirk Metalbestos® specified sealant.



METHODS OF SUPPORT

For structural support, use the Model PS Plate Support Assembly. Special dimensioned half rings and full rings are also available for guided support.

MODEL G SAMPLE SPECIFICATION FOR SINGLE WALL EXHAUST

The factory-built system shall be designed and installed to be liquid tight and thus prevent leakage of the exhaust into the building. The system shall be designed to compensate for all thermal expansion.

The single wall exhaust shall be of type 304 (or 316) stainless steel. Minimum steel thickness shall be 0.035" (or 0.048").

Pipe joints shall be sealed by use of factory supplied V-Bands and sealant.

The entire system from outlet to the termination; including accessories, except as noted; shall be from the manufacturer.

The diameter for the exhaust shall be verified by the manufacturers' computations. The computation shall be technically sound, shall follow ASHRAE calculation methods, and incorporate the specific flow characteristics of the pipe.

Specification requirements shall be met by using Selkirk Metalbestos® Model G or equivalent as approved by the responsible engineer. Equivalent bids shall specify manufacturer, model number, and other pertinent identification; and attest that the alternate is in compliance with all specification requirements.

Part Number Description:

6G304 -VL30

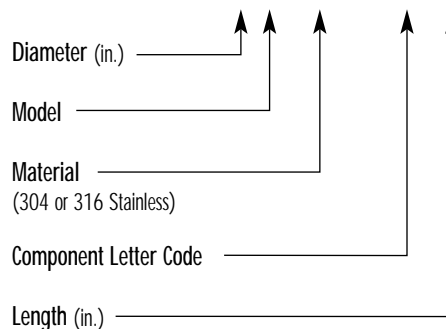

COMMON INSTALLATION TYPES

MODEL G FUME VENTING

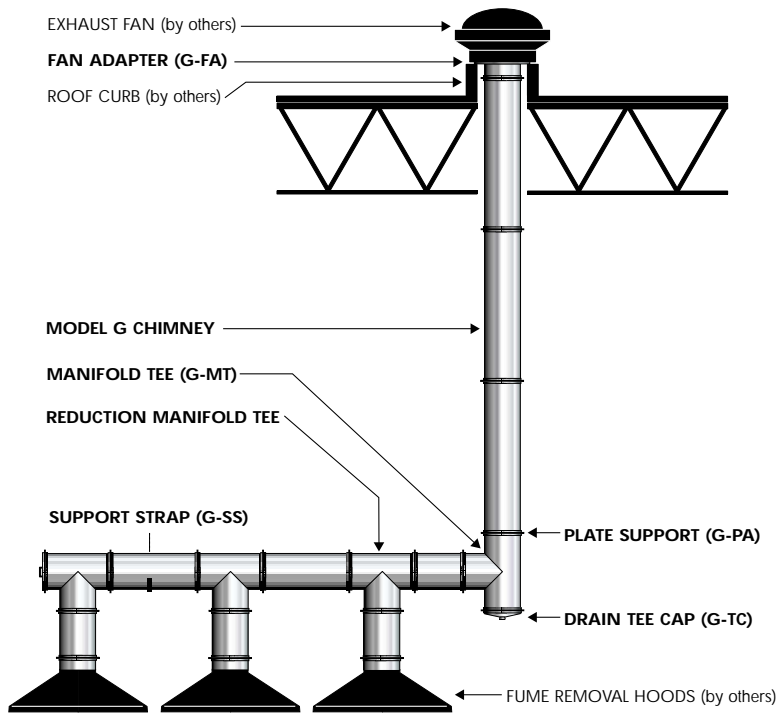

MODEL G CHIMNEY LINER

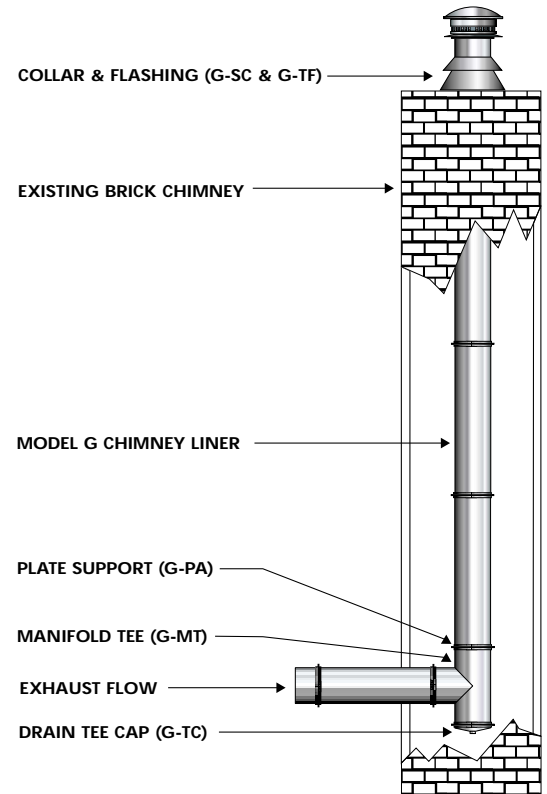

MODEL G GREASE DUCT

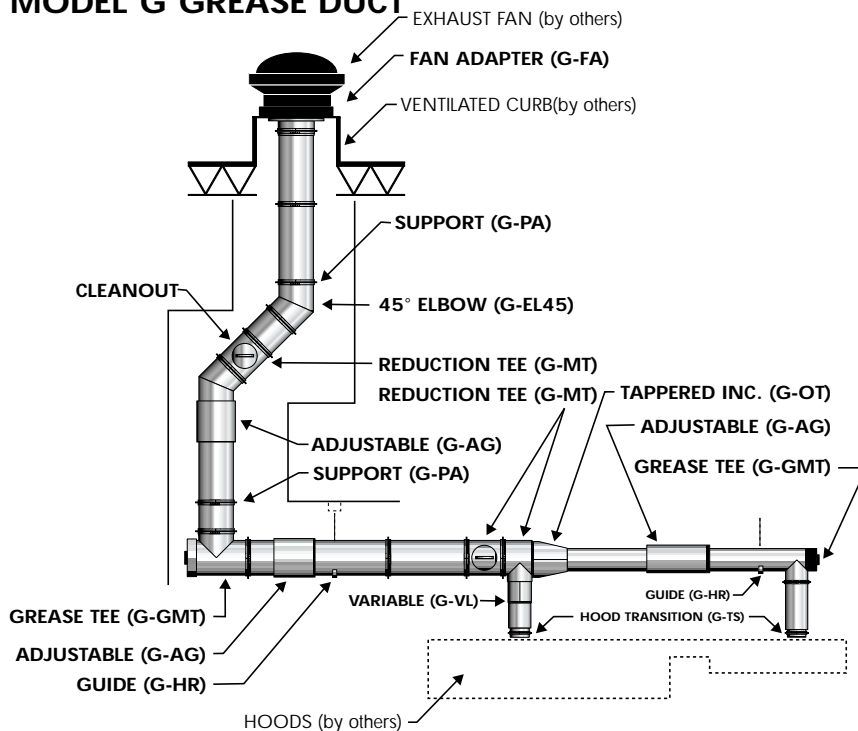

SINGLE WALL PIPE

STANDARD LENGTH CODE: 18, 30, 42 & 60

A variety of straight pipe lengths are available with Model G. Special lengths are also available and can be made with a minimum dimension of 6" diameter. Seal pipe joints with P-600 Silicone sealant for flue gas temperatures up to 600° F. For temperatures above 600° F use P-2000E high temperature sealant.

18" & 30" lengths available in all diameters 5" - 48"

42" lengths available in 6"-32" diameters

60" lengths available in 8"-14" diameters

Materials Available:

304	316
-----	-----

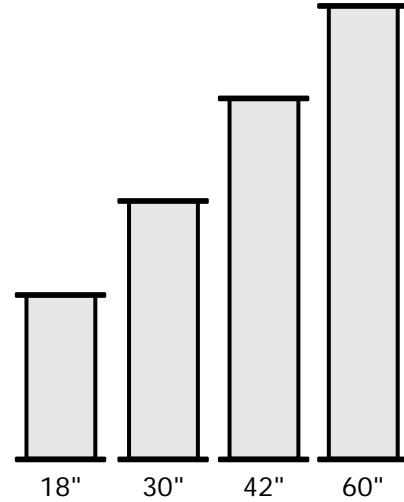

ADJUSTABLE PIPE

ADJUSTABLE LENGTH CODE: AG18 & AG30

USE: The G-AG18/30 is used for thermal expansion compensation in any pipe-line running between two fixed points.

NOTE: For diameters over 26" part G-AG30 must be used.

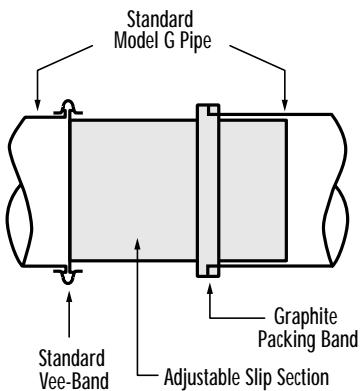

18" Adjustable length
available in 5"-26" diameters

30" Adjustable length
available in 5"-48" diameters

Flow Resistance Factor is the same as standard pipe.

Materials Available:

304	316
-----	-----

VARIABLE LENGTH CODE: AG18 & AG30

USE: Part G-VL18 is used as length to fill odd dimensions of 4" to 14". Part G-VL30 is used to fill odd dimensions of 4" to 26".

NOTE: G-VL does not allow for thermal expansion.

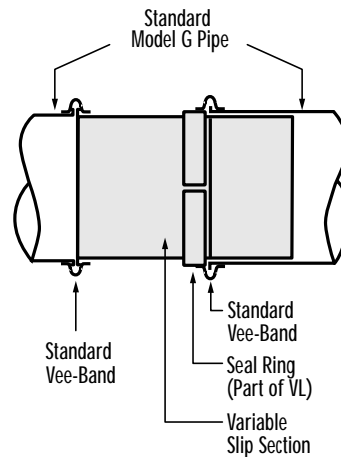

18" Adjustable length
available in 5"-48" diameters

Flow Resistance Factor is the same as standard pipe.

Materials Available:

304	316
-----	-----

NOTE:

1. Minimum installed length is 4".
2. AG 18 not available for 28" diameter and above.
3. Maximum installed space is when the inner slip section protrudes at least 1/2 pipe diameter into the adjacent pipe.
4. Flow Resistance Factor (K) is the same as insulated pipe lengths.

SINGLE WALL FITTINGS

90° TEE CODE: MT

USE: To join horizontal and vertical sections of pipe. The G-MT provides for connection for a drain or inspection fitting.

NOTE: A reduction Manifold Tee is offered.

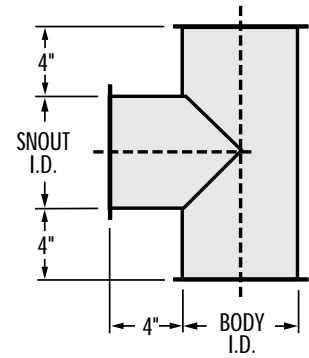

$K = 1.25$ Flow Resistance Factor

45° LATERAL TEE CODE: JL

USE: The G-JL is used to join horizontal and vertical sections of pipe at a 45 degree angle.

NOTE: A reduction G-JL is offered. A, B, and C dimensions would remain the same.

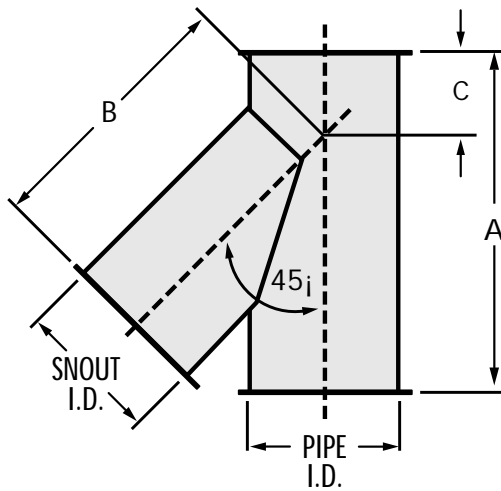

Part No.	Pipe Size I.D.	Dim. A	Dim. B	Dim. C
5G-JL	5"	19 ¹ / ₂	13 ³ / ₄	5 ³ / ₄
6G-JL	6"	19 ¹ / ₂	13 ³ / ₄	5 ³ / ₄
8G-JL	8"	22 ⁷ / ₈	16 ⁵ / ₈	6 ¹ / ₄
10G-JL	10"	24 ¹ / ₁₆	19	5 ¹ / ₁₆
12G-JL	12"	26 ¹⁵ / ₁₆	21 ⁷ / ₁₆	5 ¹ / ₂
14G-JL	14"	29 ³ / ₄	23 ⁷ / ₈	5 ⁷ / ₈
16G-JL	16"	32 ⁹ / ₁₆	26 ³ / ₄	6 ⁵ / ₁₆
18G-JL	18"	35 ³ / ₈	28 ³ / ₄	6 ³ / ₄
20G-JL	20"	38 ³ / ₁₆	31 ¹ / ₁₆	7 ¹ / ₈
22G-JL	22"	43 ⁷ / ₈	35 ⁷ / ₈	8
24G-JL	24"	43 ⁷ / ₈	35 ⁷ / ₈	8
26G-JL	26"	49 ⁹ / ₁₆	40 ³ / ₄	8 ¹³ / ₁₆
28G-JL	28"	49 ⁹ / ₁₆	40 ³ / ₄	8 ¹³ / ₁₆
30G-JL	30"	55 ³ / ₁₆	45 ⁵ / ₁₆	9 ⁵ / ₈
32G-JL	32"	55 ³ / ₁₆	45 ⁵ / ₁₆	9 ⁵ / ₈
36G-JL	36"	60 ¹³ / ₁₆	50 ³ / ₈	10 ⁷ / ₁₆
42G-JL	42"	69 ¹⁵ / ₁₆	58 ¹ / ₄	11 ³ / ₄
48G-JL	48"	79 ⁹ / ₁₆	66 ¹ / ₈	13

$K = 0.4$ Flow Resistance Factor

90° WYE CODE: JY

USE: The G-JY is intended for low pressure drop joining of two appliances.

NOTE: All openings are the same size diameter.

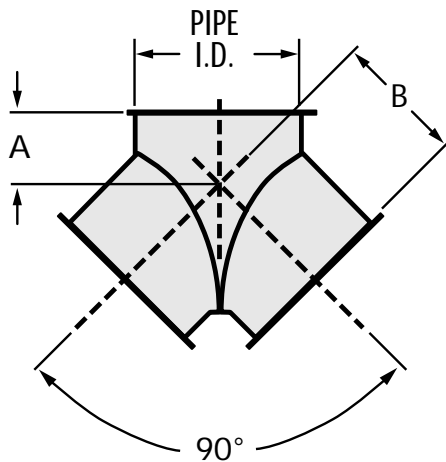

Part No.	Pipe Size I.D.	Dim. A	Dim. B
5G-JY	5"	4 ⁵ / ₈	9
6G-JY	6"	4 ⁵ / ₈	9
8G-JY	8"	5 ¹ / ₁₆	10
10G-JY	10"	5	11
12G-JY	12"	5 ¹ / ₂	12
14G-JY	14"	5 ⁷ / ₈	13
16G-JY	16"	6 ³ / ₈	14
18G-JY	18"	6 ⁵ / ₈	15
20G-JY	20"	7 ¹ / ₈	17
22G-JY	22"	8	19
24G-JY	24"	8	19
26G-JY	26"	8 ³ / ₄	22
28G-JY	28"	8 ³ / ₄	22
30G-JY	30"	9 ⁵ / ₈	24
32G-JY	32"	9 ⁵ / ₈	24
36G-JY	36"	10 ¹ / ₂	27
42G-JY	42"	11 ³ / ₄	31
48G-JY	48"	13	34

$K = 0.6$ Flow Resistance Factor

SINGLE WALL FITTINGS

30° FIXED ELBOW CODE: EL30

USE: Designed to change the direction of a breeching 30 degrees in a vertical or horizontal run.

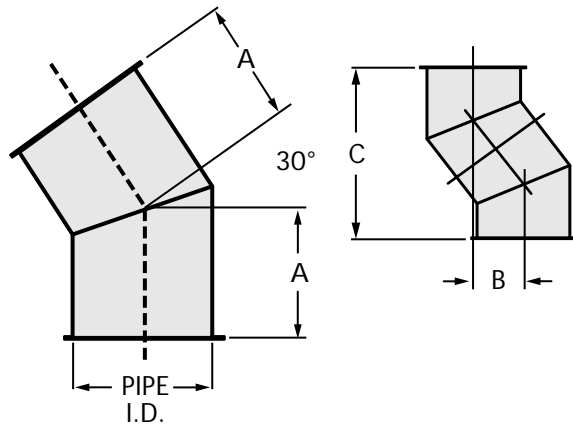

Materials Available:

304	316
-----	-----

Part No.	Pipe Size I.D.	Dim. A	Dim. B	Dim. C
5G-EL30	5"	6 ¹ / ₈	6 ¹ / ₈	22 ⁷ / ₈
6G-EL30	6"	6 ¹ / ₈	6 ¹ / ₈	22 ⁷ / ₈
8G-EL30	8"	6 ³ / ₈	6 ³ / ₈	22 ⁷ / ₈
10G-EL30	10"	6 ¹¹ / ₁₆	6 ¹¹ / ₁₆	24 ¹ / ₈
12G-EL30	12"	7 ⁵ / ₁₆	7 ⁵ / ₁₆	27 ¹ / ₄
14G-EL30	14"	7 ⁷ / ₈	7 ⁷ / ₈	29 ⁵ / ₈
16G-EL30	16"	8 ¹ / ₄	8 ¹ / ₄	30 ⁵ / ₈
18G-EL30	18"	8 ⁵ / ₈	8 ⁵ / ₈	31 ⁵ / ₈
20G-EL30	20"	9 ¹ / ₈	9 ¹ / ₈	34 ¹ / ₈
22G-EL30	22"	9 ³ / ₈	9 ³ / ₈	35
24G-EL30	24"	10 ¹ / ₁₆	10 ¹ / ₁₆	37 ¹ / ₂
26G-EL30	26"	10 ⁵ / ₁₆	10 ⁵ / ₁₆	38 ¹ / ₂
28G-EL30	28"	11	11	40 ⁷ / ₈
30G-EL30	30"	11 ¹ / ₄	11 ¹ / ₄	41 ⁷ / ₈
32G-EL30	32"	11 ⁷ / ₈	11 ⁷ / ₈	44 ³ / ₈
36G-EL30	36"	12 ⁷ / ₈	12 ³ / ₄	47 ³ / ₄
42G-EL30	42"	14	14	52 ¹ / ₂
48G-EL30	48"	14 ³ / ₁₆	14 ³ / ₁₆	56 ⁷ / ₁₆

K = 0.12 Flow Resistance Factor

45° FIXED ELBOW CODE: EL45

USE: The G-EL45 is used to join horizontal and vertical sections of pipe at a 45 degree angle.

NOTE: A reduction G-JL is offered. A, B, and C dimensions would remain the same.

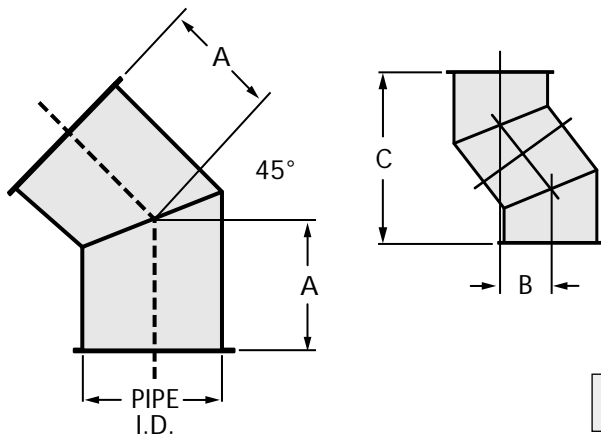

Materials Available:

304	316
-----	-----

Part No.	Pipe Size I.D.	Dim. A	Dim. B	Dim. C
5G-EL45	5"	8 ¹ / ₂	12	29
6G-EL45	6"	8 ¹ / ₂	12	29
8G-EL45	8"	8 ¹⁵ / ₁₆	12 ⁵ / ₈	30 ⁷ / ₁₆
10G-EL45	10"	9 ⁹ / ₁₆	13 ³ / ₁₆	31 ⁷ / ₈
12G-EL45	12"	10 ¹ / ₄	14 ¹ / ₂	35
14G-EL45	14"	10 ¹¹ / ₁₆	15 ¹ / ₈	36 ¹ / ₂
16G-EL45	16"	11 ⁵ / ₈	16 ⁷ / ₁₆	39 ⁵ / ₈
18G-EL45	18"	12 ¹ / ₁₆	17 ⁷ / ₁₆	41 ¹ / ₈
20G-EL45	20"	13	18 ³ / ₈	44 ¹ / ₄
22G-EL45	22"	13 ⁵ / ₁₆	18 ¹³ / ₁₆	45 ¹ / ₂
24G-EL45	24"	14 ⁵ / ₁₆	20 ¹ / ₄	48 ¹ / ₈
26G-EL45	26"	14 ⁷ / ₈	21 ¹ / ₁₆	50 ⁷ / ₈
28G-EL45	28"	15 ¹ / ₁₆	22 ³ / ₁₆	53 ¹ / ₂
30G-EL45	30"	16 ¹ / ₄	22 ¹⁵ / ₁₆	53 ³ / ₈
32G-EL45	32"	17	24	58
36G-EL45	36"	18 ³ / ₈	25 ¹⁵ / ₁₆	62 ⁵ / ₈
42G-EL45	42"	19 ¹ / ₁₆	27 ⁷ / ₈	67
48G-EL45	48"	21 ¹ / ₁₆	30 ⁵ / ₁₆	74 ⁷ / ₈

K = 0.15 Flow Resistance Factor

90° FIXED ELBOW CODE: EL90

USE: The G-EL90 is used to join horizontal and vertical sections of pipe at a 90 degree angle.

NOTE: All openings are the same size diameter.

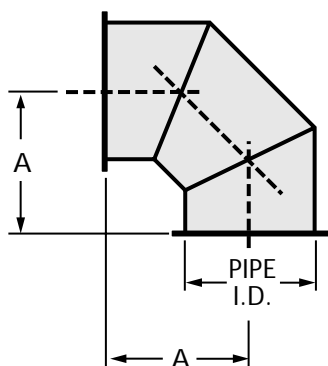

Materials Available:

304	316
-----	-----

Part No.	Pipe Size I.D.	Dim. A
5G-EZ90	5"	11 ¹ / ₂
6G-EL90	6"	11 ¹ / ₂
8G-EL90	8"	12 ¹ / ₂
10G-EL90	10"	13 ¹ / ₂
12G-EL90	12"	14 ¹ / ₂
14G-EL90	14"	15 ¹ / ₂
16G-EL90	16"	16 ¹ / ₂
18G-EL90	18"	17 ¹ / ₂
20G-EL90	20"	18 ¹ / ₂
22G-EL90	22"	19 ¹ / ₂
24G-EL90	24"	20 ¹ / ₂
26G-EL90	26"	21 ¹ / ₂
28G-EL90	28"	22 ¹ / ₂
30G-EL90	30"	23 ¹ / ₂
32G-EL90	32"	24 ¹ / ₂
36G-EL90	36"	26 ¹ / ₂
42G-EL90	42"	29 ¹ / ₂
48G-EL90	48"	32 ¹ / ₂

K = 0.30 Flow Resistance Factor

SINGLE WALL FITTINGS

15° ELBOW

USE: Two-piece Elbow can establish many different degrees when combined with other standard Elbows.

CODE: **EL15**

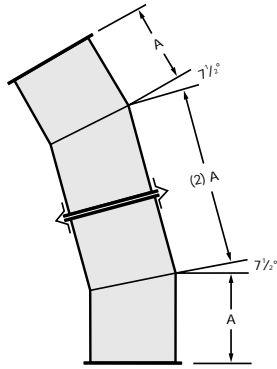

Part No.	A
5G-EL15	4 ³ / ₁₆ "
6G-EL15	4 ³ / ₁₆ "
8G-EL15	4 ¹ / ₄ "
10G-EL15	4 ⁵ / ₁₆ "
12G-EL15	4 ⁷ / ₁₆ "
14G-EL15	4 ¹ / ₂ "
16G-EL15	4 ⁹ / ₁₆ "
18G-EL15	4 ⁵ / ₈ "
20G-EL15	4 ¹¹ / ₁₆ "
22G-EL15	4 ³ / ₄ "
24G-EL15	4 ¹³ / ₁₆ "
26G-EL15	4 ⁷ / ₈ "
28G-EL15	4 ¹⁵ / ₁₆ "
30G-EL15	5
32G-EL15	5 ¹ / ₁₆ "
36G-EL15	5 ³ / ₁₆ "
42G-EL15	5 ³ / ₈ "
48G-EL15	5 ⁹ / ₁₆ "

K = 0.06 flow resistance factor

Materials Available:

304	316
-----	-----

TAPERED INCREASER/REDUCER

USE: Used when a pipe diameter change is required.

CODE: **OT**

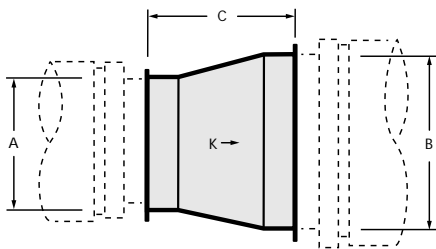

Dimensions:

A = Smaller Diameter

B = Larger Diameter

C = Installed Length = [(B-A) 2] + 2 (see Note 1 below)

Example:

Installed Length for 12P304-180T equals [(18-12)2] + 2 = 14 inches.

Notes:

1. Installed length shall not be greater than longest available straight pipe length.

2. $K = N [1 - (A/B)^2]^2$

where N = 0.47 for one step OT

N = 0.53 for one step OT

Materials Available (shaded areas):

304/Alum	316/Alum	304/304	316/316
----------	----------	---------	---------

90° GREASE DUCT TEE

USE: Part MT with dam added for protection against fluids running out while cleaning.

CODE: **GMT**

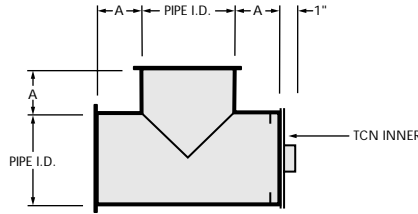

A = 4"

K = 1.25 flow resistance factor

Materials Available:

304	316
-----	-----

CLEANOUT TEE CAP

USE: Used to close Tee opening at the base of a stack or the end of a horizontal run.

CODE: **TCN**

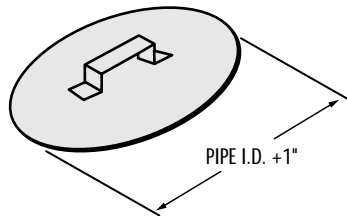

Part No. (pipe I.D.) G-TCN

Includes one OVB

Materials Available:

304	316
-----	-----

DRAIN SECTION DS

USE: Used with open stack terminations for draining off rain water from inside vertical or horizontal flue.

CODE: **DS**

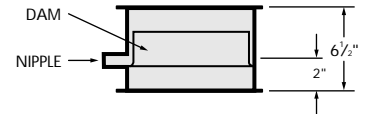

K = 0.25 flow resistance factor

Materials Available:

304	316
-----	-----

DRAIN TEE CAP

USE: Provides a drain at the base of a vertical chimney when connected to the MT or JL

CODE: **TC**

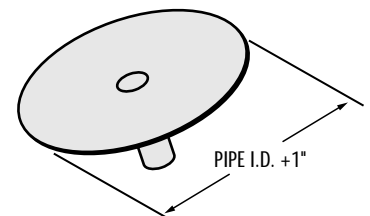

Part No. (pipe I.D.) G-TC

1" N.P.T. nipple on 5"-20" sizes

2" N.P.T. nipple on 22"-48" sizes

Includes one OVB

Materials Available:

304	316
-----	-----

CONNECTION ACCESSORIES

NOZZLE SECTION

USE: For use as fire suppression nozzle section or hot water/detergent maintenance section.

CODE: **FN**

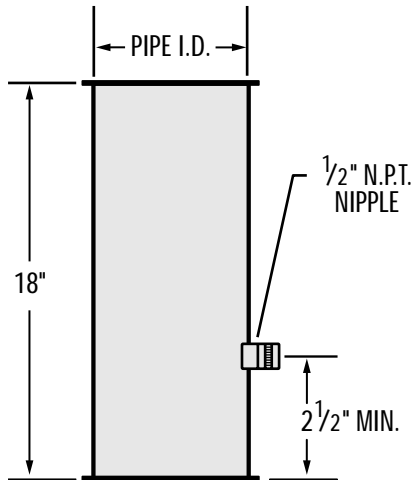

Materials Available:

304	316
-----	-----

HOOD TRANSITION

USE: Securing Model G to flanged appliance outlets.

CODE: **TS**

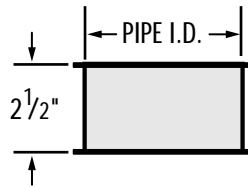

Materials Available:

304	316
-----	-----

HOOD TRANSITION (Unflanged)

USE: Securing Model G to unflanged appliance outlets.

CODE: **TSU**

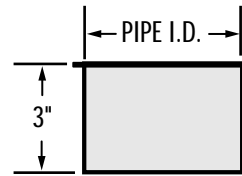

Materials Available:

304	316
-----	-----

FAN ADAPTER FA

USE: Designed to secure Model G to fan inlet.

CODE: **FA**

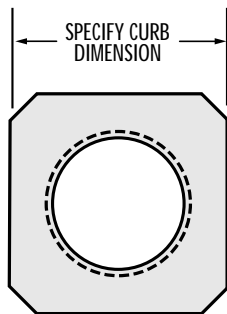
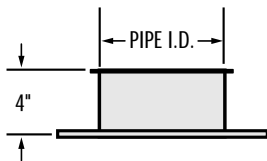

Materials Available:

304	316
-----	-----

JOINT ASSEMBLY PARTS

SEAL RING

USE: Used for non-welded attachment to appliances having an unflanged or collar outlet.

CODE: **SR**

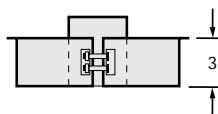

Materials Available:

316

OVERLAPPING VEE BAND

USE: Used to seal the flange of two adjoining components

CODE: **OVB**

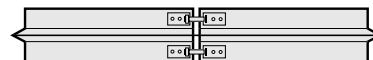

Notes:

1. 5", 6", 8", and 48" diameter VB's are two-piece design. 10" through 36" diameter VB's are a one-piece design.

SUPPORT/GUIDE ACCESSORIES

WALL GUIDE ASSEMBLY

USE: Same use as FR, but with factory-supplied bracing.

CODE: **WG**

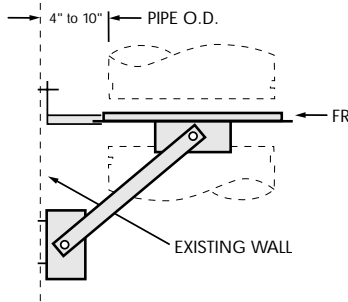

Ordered Part Included:

One FR, four struts, and six brackets.

Notes:

1. Assembly will maintain a 6 to 11" clearance between pipe O.D. and supporting structure.

Materials Available:

Electroplated or Galvanized Steel

WALL SUPPORT ASSEMBLY

USE: "Limited" support assembly with factory-supplied bracing

CODE: **WA**

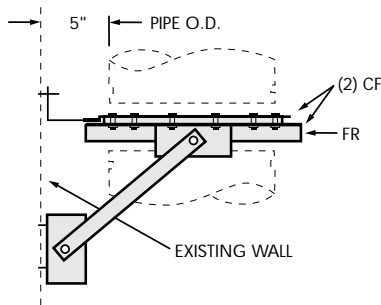

Ordered Part Includes:

One FR, two CF's, two HCB's, five brackets, two struts, and all hardware except connection at wall.

Notes:

1. Assembly will maintain a 5" clearance between pipe O.D. and supporting structure.

Materials Available:

Electroplated or Galvanized Steel

PLATE SUPPORT ASSEMBLY

USE: Used for supporting the load of the stack, and as a fixed point anchor near fittings.

CODE: **PA**

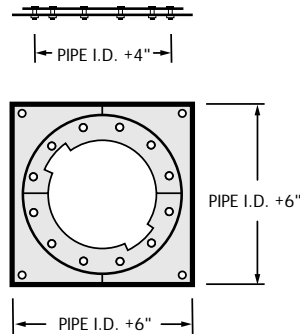

Ordered Part Includes:

Split (square) plate, one CF, two HCB's and hardware.

Plate Thickness:

- 0.188" for sizes 5" through 20" i.d. diameters
- 0.250" for sizes 22" through 36" i.d. diameters
- 0.375" for sizes 42" through 48" i.d. diameters

Notes:

1. Two 316 Stainless Steel HCB's should be ordered separately for stainless steel outer projects.
2. PA fabricated from 304 Stainless Steel is available upon request and is non-returnable. Allow extra manufacturing time.

Materials Available:

Electroplated or Galvanized Steel

SUPPORT STRAP

USE: Available in 5" through 28" Ø G only. 0.188" Thick Rolled Steel.

CODE: **SS**

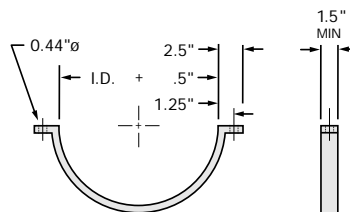

Materials Available:

Hot Rolled Steel

ANGLE RINGS

USE: Used for guiding and/or supporting horizontal installations.

CODE: **HR & FR**

HR - Half Ring

FR - Full Ring

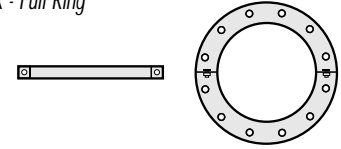

PART NO.	BOLT HOLE	I.D. OF RING	# OF HOLES	SIZE OF ANGLE	ANGLE
5G-HR	9	5 1/8	6	(1)	45
6G-HR	10	6 1/8	6	(1)	45
8G-HR	12	8 1/8	6	(1)	45
10G-HR	14	10 1/8	6	(1)	45
12G-HR	16	12 1/8	6	(1)	45
14G-HR	18	14 1/8	6	(1)	45
16G-HR	20	16 1/8	6	(1)	45
18G-HR	22	18 1/8	6	(1)	45
20G-HR	24	20 1/8	6	(1)	45
22G-HR	26	22 1/8	10	(2)	22.5
24G-HR	28	24 1/8	10	(2)	22.5
26G-HR	30	26 1/8	10	(2)	22.5
28G-HR	32	28 1/8	10	(2)	22.5
30G-HR	34	30 1/8	10	(2)	22.5
32G-HR	36	32 1/8	10	(2)	22.5
36G-HR	40	36 1/8	10	(2)	22.5
42G-HR	46	42 1/8	10	(2)	22.5
48G-HR	52	48 1/8	10	(2)	22.5

(1) Size of Angle = 1 1/2 X 1 1/2 X 3/8

(2) Size of Angle = 2 X 2 X 3/16

Materials Available:

Electroplated or Galvanized Steel

ROOF PENETRATIONS

STORM COLLAR

USE: Used above the TF and PTF for complete weatherization above the roof.

CODE: **SC**

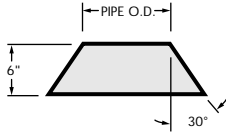

Notes:

1. Requires P600 sealant when installing.

Materials Available:

Aluminum or Galvanized Steel	304	316
------------------------------	-----	-----

TALL FLASHING TF

USE: Used in conjunction with SC for weatherization at the roof.

CODE: **TF**

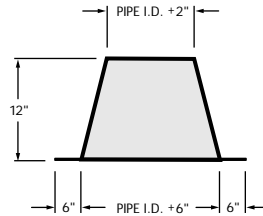

Notes:

1. Use limited to installations where complete roof penetration is non-combustible

Materials Available:

Aluminum or Galvanized Steel	304	316
------------------------------	-----	-----

PITCHED TALL FLASHING PTF

USE: Same function as TF, except for use on a pitched roof.

CODE: **PTF**

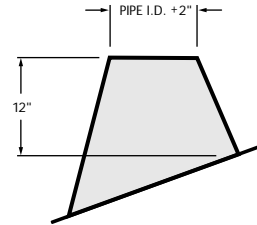

Notes:

1. Part is non-returnable and may require extra manufacturing time. Specify pitch when ordering
2. Use limited to installations where complete roof penetration is non-combustible

Materials Available:

Aluminum or Galvanized Steel	304	316
------------------------------	-----	-----

TERMINATIONS

CHIMNEY ROUND TOP

USE: Provides the greatest degree of rain protection. Available only in 5", 6", 8", 10", 12", and 14" sizes.

CODE: **CT**

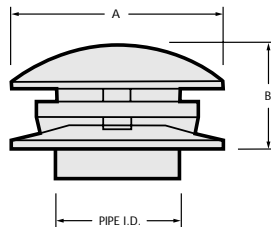

Part No.	Dim. A	Dim. B
5G-CT	12	5½
6G-CT	12	5½
8G-CT	16	7
10G-CT	20	8½
12G-CT	24	10
14G-CT	28	11½

*K = 0.5 Flow
Resistance Factor*

Materials Available:

430 Stainless Steel Only

STACK CAP

USE: Provides partial protection with low flow resistance. May require a drain at base of stack.

CODE: **SK**

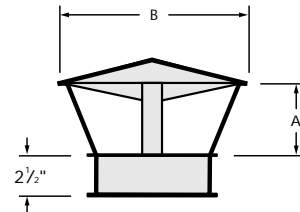

Part No.	Dim. A	Dim. B
5G-SK	2½	10¼
6G-SK	3	10¼
8G-SK	4	13¾
10G-SK	5	17
12G-SK	6	20½
14G-SK	7	24
16G-SK	8	27¾
18G-SK	9	30¾
20G-SK	10	34½
22G-SK	11	37¾
24G-SK	12	41
26G-SK	13	44¾
28G-SK	14	47¾
30G-SK	15	51¼
32G-SK	16	54¾
36G-SK	18	61½
42G-SK	21	71¼
48G-SK	24	82

*K = 0.5 Flow
Resistance Factor*

Materials Available:

316

EXIT CONE

USE: Will increase stack exit velocity 1½ times. Requires a drain at the bottom of stack.

CODE: **EC**

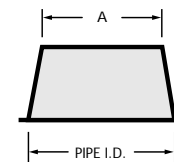

Part No.	Dim. A
5G-EC	4¾
6G-EC	4¾
8G-EC	6¾
10G-EC	8¾
12G-EC	9¾
14G-EC	11½
16G-EC	13¾
18G-EC	14¾
20G-EC	16¾
22G-EC	18
24G-EC	19¾
26G-EC	21¼
28G-EC	2¾
30G-EC	24½
32G-EC	26¾
36G-EC	29¾
42G-EC	34¾
48G-EC	39¾

*K = 0.5 Flow
Resistance Factor*

Materials Available:

316

LOW TEMPERATURE SEALANT CODE: **P600**
HIGH TEMPERATURE SEALANT CODE: **P2000E**

Depending upon the application, either or both of Selkirk's low-temperature and high temperature sealants are applied to the OVB before connecting two Inner Pipes at installation. As designed, P600 Sealant is for 600° F. maximum flue gas temperatures, while P2000E is capable for flue gases up to 2,000° F.

SEALANT COVERAGE (Expected number of joints sealed per tube)

Inner Diameter (inches)	5/6	8/10	12	14/16	18/20	22/24	26/28	30/32	36	42/48
P600 & P2000E	10	9	8	7	6	5	4	3	2	1

We have available a variety of special dimension single wall fittings similar to those found in our regular PS/IPS product catalog.

EXTENDED 10-YEAR WARRANTY

Selkirk Metalbestos warrants the chimney, grease duct, engine exhaust system and components against functional failure due to defects in material and workmanship for a period of ten years from date of delivery to the construction site. Functional failure is defined as any failure of the system or a component to perform its intended function of exhausting, without adverse leakage, combustion by-products from engine operation or boiler heating equipment. During this period, any system or component supplied by Selkirk Metalbestos failing to perform its intended function will be repaired or replaced at the manufacturer's option, following determination by a factory-authorized inspector that a functional failure has occurred.

This warranty is limited to repair or replacement of the product plus shipping cost to the failure location. This warranty does not cover any labor costs for removal or replacement of the defective product, nor does this warranty cover any system components not furnished by Selkirk Metalbestos and installed as part of the system.

This limited warranty is extended to the purchaser subject to the satisfaction of the following conditions:

- 1) System sizing and design has been performed by Selkirk Metalbestos personnel, and design parameters provided to Selkirk Metalbestos by the responsible engineer were and are accurately representative of the operating conditions.
- 2) The undamaged components have been correctly installed in accordance with system design and

sizing as performed by Selkirk Metalbestos and installation instructions published by Selkirk Metalbestos at the time of shipment.

- 3) Proper precautions have been taken to insure that boiler or engine combustion air is free of solvent or refrigerant vapors or any halogenated compound which may cause acid condensates to form within the chimney.
- 4) Selkirk Metalbestos has supplied the entire chimney or exhaust system from boiler/engine outlet to the termination of the stack.
- 5) Prior to start-up and thereafter, exposed aluminized steel surfaces are protected with a minimum of one base coat of primer and one finish coat of heat-resistant and corrosive-resistant paint at all times. Stainless steel surfaces need not be primed or painted.

Selkirk Metalbestos assumes no liability for incidental or consequential damages of any kind or for any damages resulting in whole or in part from misuse, improper installation, or inadequate maintenance of the system or any component part thereof. This warranty is in lieu of all other express warranties or guarantees of any kind. All implied warranties, including merchantability and fitness, are limited to the duration of the express warranty contained herein. Selkirk Metalbestos neither assumes nor does it authorize any other person to assume on its behalf any other liability in connection with the sale of its products.

For prompt warranty service, contact the nearest Selkirk Metalbestos Commercial/Industrial Venting Products Agent, or Selkirk Metalbestos Customer Service Department, P. O. Box 631, Logan, Ohio 43138

ENGINEERED FOR TOMORROWS SOLUTIONS . . .

FIELD TECHNICAL SERVICES

To assist users of our products, Metalbestos® venting specialists throughout the U.S. conduct field investigations to help solve unusual venting problems. They also give assistance on building code and materials approval questions.

For complicated projects, our technical staff can prepare detailed take-offs from architectural drawings. And, the Selkirk seminars are still another valuable field aid available to contractors, building officials and utility service people.

FACTORY ENGINEERING SERVICES

The Selkirk venting laboratory are some of the most advanced in the world and have conducted hundreds of tests to solve unusual venting problems. The Selkirk engineering staff provides design services for special product applications and for installations requiring complex or unusual manifold systems.

FIELD SALES

Selkirk Commercial/Industrial representatives throughout North America are qualified to provide field service to assist contractors, builders, engineers and architects in designing Boiler Stacks and Breechings, Grease Ducts, Diesel and Turbine Exhausts, Freestanding Stack Systems, and Residential Chimney and Gas Vent Systems. Please visit our web site for the representative nearest you or call one of our offices listed below.



Selkirk Inc. offers customers a 10 Year Limited Warranty on all Metalbestos Model G Venting Systems, subject to certain warranty conditions. For a copy of the warranty, please contact us or visit our website.

HEADQUARTERS

14801 Quorum Drive
Dallas, Texas 75240-7584
WEB: www.selkirkinc.com

RESEARCH & DEVELOPMENT

2000 Chennault Drive
Carrollton, Texas 75006
(972) 661-0308
Fax (972) 661-0164

MANUFACTURING & RESEARCH/DEVELOPMENT

St. Rt. 93 N. & Sutton Rd.
Logan, Ohio 43138
(800) 848-2149
Fax (740) 385-2483

1820 E. Fargo Ave.
Nampa, Idaho 83687-6824
(800) 635-6507
Fax (208) 467-7412

COMMERCIAL CUSTOMER SERVICE - EAST

Logan, Ohio
(740) 385-5666
(800) 848-2149 ext. 401 & 402
Fax (740) 385-1709

COMMERCIAL CUSTOMER SERVICE - WEST

Nampa, Idaho
(208) 467-7411
(800) 635-6507 ext. 251
Fax (888) 877-6306

SELKIRK, INC. is a leading manufacturer of venting products for residential, commercial and industrial applications. Current operations include locations in the United States, Canada and Mexico. SELKIRK, INC. has been supplying the finest venting products for over 75 years.



www.selkirkinc.com