

MODEL 4" UT

INSTALLATION INSTRUCTIONS AND MAINTENANCE GUIDE (CANADA & UNITED STATES)

FACTORY-BUILT CHIMNEY

Tested To:
CAN/ULC-S604 STANDARD FOR FACTORY-BUILT
TYPE A CHIMNEYS

UL-103 STANDARD FOR FACTORY-BUILT CHIMNEYS
FOR RESIDENTIAL TYPE AND BUILDING HEATING
APPLIANCES.



LISTED

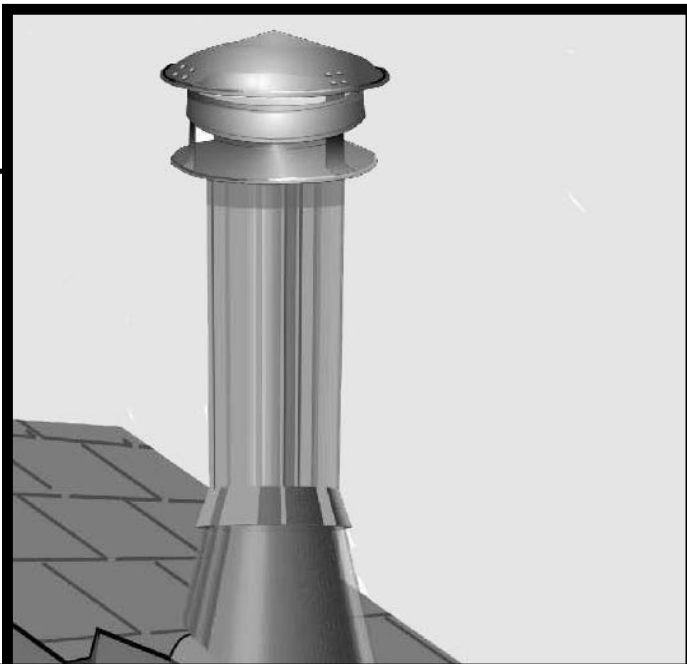

A MAJOR CAUSE OF CHIMNEY
RELATED FIRES IS FAILURE TO
MAINTAIN REQUIRED CLEARANCES
(AIR SPACES) TO COMBUSTIBLE
MATERIALS.

IT IS OF THE UTMOST IMPORTANCE
THAT THIS CHIMNEY BE INSTALLED
ONLY IN ACCORDANCE WITH THESE
INSTRUCTIONS.

**PLEASE READ ALL INSTRUCTIONS BEFORE BEGINNING YOUR
INSTALLATION. FAILURE TO INSTALL THIS SYSTEM IN ACCORDANCE WITH
THESE INSTRUCTIONS WILL VOID THE CONDITIONS OF CERTIFICATION AND
THE MANUFACTURERS WARRANTY. KEEP THESE INSTRUCTIONS
IN A SAFE PLACE FOR FUTURE REFERENCE.**



SELKIRK CORPORATION
5030 Corporate Exchange Blvd., SE,
Grand Rapids, MI 49512
1-(800)-992-VENT (8368)
info@selkirkcorp.com



 **SELKIRK**®

www.selkirkcorp.com

SELKIRK CANADA
P.O. Box 526, Depot 1
Hamilton, Ontario L8L 7X6
1-888-SELKIRK (735-5475)
info@selkirkcanada.com

CERTIFICATION LABELS

 LISTED MH6673 USA: UL 103 HT (4" to 8"); UL 103 and UL 2561 (10" to 24") Canada: CAN/ULC-S604 (4" to 24") and ULC/ORD-C858 (16" to 24")	RESIDENTIAL TYPE AND BUILDING HEATING APPLIANCE CHIMNEY PART	PIÈCE COMPOSANTE POUR APPAREIL DE CHAUFFAGE DE TYPE RÉSIDENTIEL D'IMMEUBLE
	MODÈLE: UT / UTL MODEL:	MINIMUM AIR SPACE CLEARANCE TO COMBUSTIBLES 2" (50mm) OR AS ESTABLISHED BY FACTORY SUPPLIED SPACERS AND SUPPORT ASSEMBLY. FOLLOW MANUFACTURERS INSTALLATION INSTRUCTIONS PACKAGED WITH SUPPORT ASSEMBLY. SUITABLE FOR INTERIOR AND EXTERIOR INSTALLATION. WARNING! FAILURE TO FOLLOW THE INSTALLATION INSTRUCTIONS COULD CAUSE FIRE, CARBON MONOXIDE POISONING, OR DEATH. IF YOU ARE UNSURE OF THE INSTALLATION REQUIREMENTS VISIT OUR WEBSITE: WWW.SELKIRKCORP.COM .
LISTED PER CAN/ULC-S604 FOR CONNECTION TO LIQUID OR GAS FIRED APPLIANCES NORMALLY PRODUCING FLUE GASES OF 540° C OR LESS. ALSO FOR USE WITH SPECIFIC FACTORY-BUILT FIREPLACES WHERE SPECIFIED IN THE FIREPLACE MANUFACTURERS INSTALLATION INSTRUCTIONS.		ESPACE POUR L'AIR MINIMALE AUX MATIÈRES COMBUSTIBLES 2" (50mm) OU TEL QUE DÉTERMINÉ PAR LE FABRICANT DU COUPE-FEU. DOIT ÊTRE INSTALLÉ SUIVANT LES INSTRUCTIONS D'INSTALLATION DU MANUFACTURIER EMPAQUETTES AVEC LE SUPPORT. CONVIENT À UNE INSTALLATION INTÉRIEURE OU EXTÉRIEURE. AVERTISSEMENT! NE PAS SUIVRE CES INSTRUCTIONS D'INSTALLATION PEUT CAUSER FEU, EMPOISONNEMENT AU MONOXYDE DE CARBONE OU LA MORT, SI VOUS ÊTES INCERTAINS SUR LES PROCÉDURES D'INSTALLATION, VEUILLEZ COMMUNIQUER EN VISITANT NOTRE SITE: WWW.SELKIRKCORP.COM .
Part # : No. de pièce: SAMPLE LABEL		 1 23456 78901 2
 GRAND RAPIDS, MI		09/21/18 REVO 1890090135

 LISTED MH6673 USA: UL 103 HT (4" - 8"); UL 103; UL 2561 (10" - 24") Canada: CAN/ULC-S604 (4" - 24"); ULC/ORD-C858 (16" - 24") CAN/ULC-S628 - ONLY/SEULEMENT - Model/modèle CF Sentinel (6" - 8")	RESIDENTIAL TYPE AND BUILDING HEATING APPLIANCE CHIMNEY PART	PIÈCE COMPOSANTE POUR APPAREIL DE CHAUFFAGE DE TYPE RÉSIDENTIEL D'IMMEUBLE
	MODEL / MODELE: UT / UTL	
SELKIRK CHIMNEY SYSTEM		
PART NUMBER: NO. DE PIÈCE: SAMPLE LABEL		 1 23456 78901 2
PRODUCT #:		
 GRAND RAPIDS, MI		09/24/18 123456789012345678 12345678901234567890123 REVO 1890100135

CAUTION:

READ ALL INSTRUCTIONS CAREFULLY BEFORE STARTING THE INSTALLATION. FAILURE TO COMPLY WITH INSTRUCTIONS WILL VOID CHIMNEY CERTIFICATION AND COULD RESULT IN DEATH, SERIOUS BODILY INJURY AND/OR PROPERTY DAMAGE.

U.S.A. APPLICATIONS

In U.S.A., Model 4UT has been tested per UL103 as a "Type HT" chimney by Underwriters Laboratories, Inc. As such it is code approved for connection to solid, liquid or gas fueled appliances producing continuous flue gases temperatures not in excess of 1000°F.

Factory built chimneys are intended for installation in accordance with NFPA 211 (Standard for Chimneys, Fireplaces, Vents and Solid Fuel Fired Appliance), and / or local and regional codes such as the International Mechanical Code and Uniform Mechanical Code, etc.

Your installation should comply with the appropriate Installation Codes.

This chimney system is suitable for venting gas, oil or solid fuel fired appliances including wood stoves, furnaces, boilers and fireplaces.

CANADA APPLICATIONS

In Canada, Model 4UT is intended for connection to liquid fuel or gas fired residential type appliances and building heating appliances, in which the maximum continuous flue gas temperatures do not exceed 540°C (1000°F) as per ULC-S604.

In Canada, a solid fueled appliance must be connected to a chimney system listed to CAN/ULC-S629.

This chimney is intended for use in accordance with: CAN/CSA-B149 Installation Code for Gas Equipment; CAN/CSA-B139 Installation Code for Oil Burning Equipment; Appliance and Venting manufacturer's instructions.

Attic Insulation Shield and sealing of chimney at any penetration of the building envelope (Canada)

In attics with blown-in or batt insulation, the chimney must either be fully enclosed or an Attic Insulation Shield must be used to create and maintain the proper minimum airspace clearances to combustibles. The height of the Attic Insulation Shield must accommodate the amount of insulation as required by the National Building Code. Where height restrictions will not permit the use of the Attic Insulation Shield, it is permissible to construct an enclosure with the required air space clearance to combustibles (see Table 1 for proper minimum air space clearance) to the outer pipe all the way to the underside of the roof deck. In this application you will install a Firestop Joist Shield on the ceiling side.

At the level where the chimney penetrates the air / vapour barrier, special attention is required. Seal the vapour barrier to the Firestop Spacer, Wall Thimble or Attic Insulation Shield using an appropriate caulking compound as per the requirement of local authorities.

GENERAL

The safe operation of a factory-built chimney assembly is based on the use of parts supplied by the manufacturer. The performance of the assembly may be affected if the combination of these parts is not used in actual building construction. Flue gas conveying components of this chimney system must not be field modified. Unauthorized modifications

and/or conveying components of this chimney system must not be field modified. Unauthorized modifications and/or failure to follow manufacturers installation instructions will void chimney certification and warranty.

Do not fill the chimney enclosure with loose fill or any other insulating material. This volume must remain open and clear. If a screw penetrates the outer skin it should be sealed with silicone to prevent moisture from seeping into the insulation.

Contact local building and/or fire officials before installation to determine if a permit and/or inspection is required.

Consult your home insurance company for possible restrictions. Have your installation inspected by qualified authorities.

SELKIRK WILL NOT BE HELD LIABLE FOR ANY DAMAGES OR LOSSES ARISING OUT OF IMPROPER CARE, HANDLING, INSTALLATION OR USE OF THIS CHIMNEY.

PLANNING AND LAYOUT

1. When locating your appliance, consider the building structure to ensure the chimney will not interfere with any ceiling joists, roof rafters, wall studs, water pipes or electrical wiring. It may be easier to relocate the appliance than to rework the building structure.
2. Before starting the installation, be sure that you have all chimney parts in undamaged condition.
3. Read appliance instruction manual for any further layout restrictions.
4. A Black Ceiling Support will support up to 50 feet of chimney.
5. The chimney must rise at least 3 feet above the roof penetration and at least 2 feet above any obstacle within 10 feet (horizontally) of the chimney.

Minimum Framing Dimension		
	Inches	mm
At Ceiling Support	9" X 9"	229 x 229
Above Ceiling Support	10" X 10"	254 x 254

6. If the chimney extends five feet or more above the roof penetration, a Roof Brace Kit must be used to provide lateral support.
7. In geographical regions experiencing sustained low ambient temperatures it is recommended to enclose exterior chimneys below the roof line. This should help reduce condensation, creosote accumulation, and poor drafting.
8. A chimney must be enclosed in any inhabited story above the appliance. In a building other than a one or two family dwelling, the enclosure material shall have a fire resistance rating at least equal to the adjacent floor or ceiling material.
9. Correct sizing of the chimney to the appliance is an important factor in venting performance. A chimney that is either too large or too small will have poor drafting characteristics. The possible consequences include excessive condensation of moisture and/or soot build up.
10. Any screws that penetrate the outer skin should be sealed with silicone to prevent moisture from reaching the insulation.

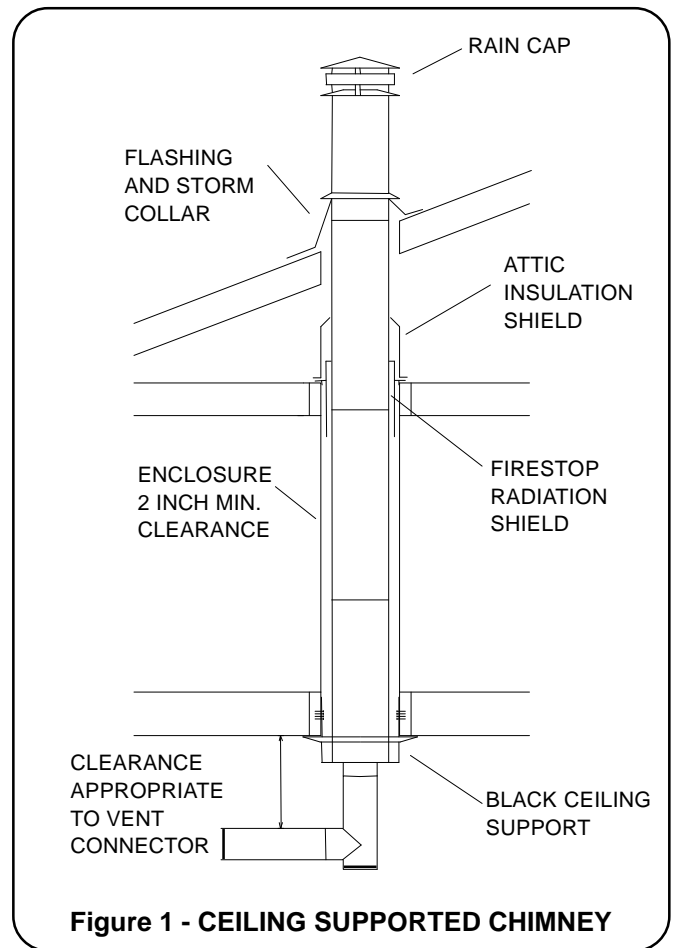

CLEARANCES

Minimum clearances to combustibles is 2" (50mm).

The above required airspace clearances must not be filled with loose fill or any other insulating material. This volume must remain open and clear.

1. CEILING SUPPORTED CHIMNEY

INSTALLATION:

This is the simplest installation and should be used whenever possible. Refer to the appropriate detail Figures for clearer illustrations of each component.

- 1.1. General CHIMNEY layout is shown in Figure 1.
- 1.2. A Black Ceiling Support will support up to 50 feet of chimney.
- 1.3. Position the appliance in the desired location according to the appliance instructions.
- 1.4. Use a plumb line to determine location of CHIMNEY penetration of ceiling.

- 1.5. Cut and frame a 9" X 9" opening in the ceiling. Framing material shall be the same as that of adjacent joist material. Hole in the ceiling material (only) should be cut round with same diameter as CEILING SUPPORT.
- 1.6. Install the Black Ceiling Support from below joist level and fasten with 16 - 1.5" spiral nails or screws (4 per side) as per Figure 2.

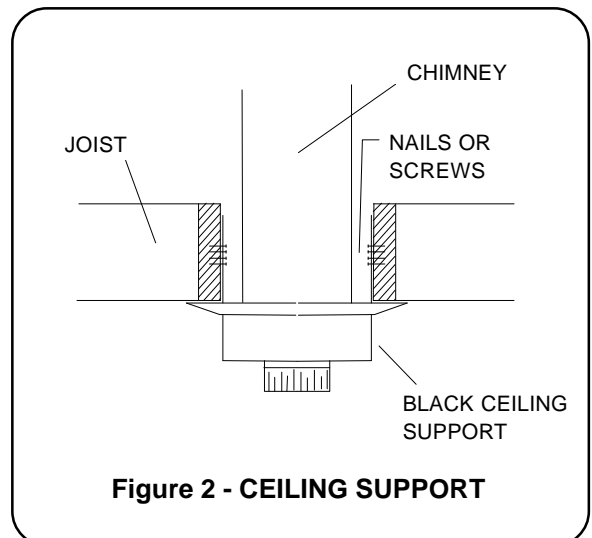

- 1.7. Lower the first chimney section into the Black Ceiling Support and twist lock it into place.
- 1.8. Install the next chimney section(s) atop the first. Twist lock sections together with a clock-wise turn. In addition, fasten the joint with a #8 x 1/2" screw (provided) through the 3/16" pre-punched hole.
- 1.9. Firestop Radiation Shields are required where the chimney penetrates a floor or ceiling. Cut a hole of 10" X 10" in the ceiling/floor and install the FRS from above the joist. Fasten the FRS with nails through the corners of the firestop. See Figure 3.

OCCUPIED ATTIC SPACE:

If the attic space is occupied, the following instructions must be followed. If the attic space is unoccupied skip down to instruction 1.14.

- 1.10. In an occupied attic, enclose the chimney as on all other floor levels. Do not use an ATTIC INSULATION SHIELD if the chimney is enclosed in the attic! See Figures 3 and 4.
- 1.11. A Vented Flashing and Roof Radiation Shield is used to finish off the roof above an enclosed attic.

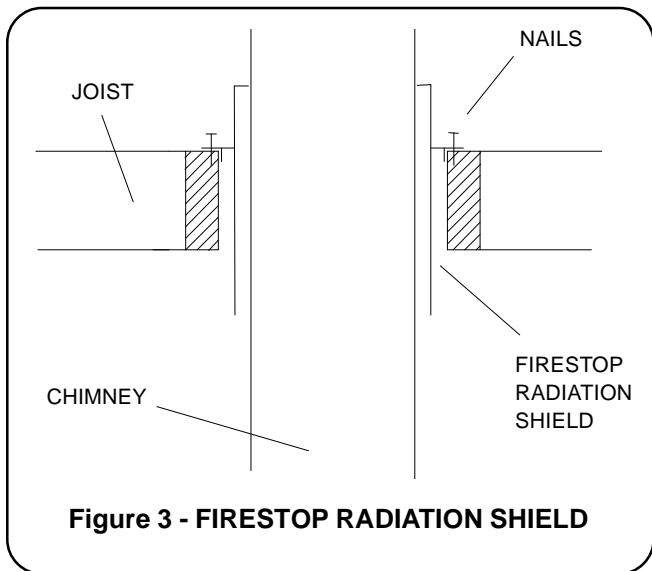

- 1.12. Lower the Roof Radiation Shield down over the chimney until its brackets sit on the roof line. Fasten these brackets to the roof with roofing nails. Slide the Flashing down over the chimney and center it over the roof opening. Slip the upper side of the flashing

base under the roof shingles and lay the lower side over the shingles. Nail the Flashing to the roof with a minimum of 8 roofing nails. Seal the Flashing base with appropriate roofing mastic. See Figure 4.

- 1.13. Slide the Storm Collar over the chimney until it sits on the spacer tabs of the Vented Flashing. Tighten the collar's clamp screw. Seal around the top of the Storm Collar with silicone. Do not seal the opening between the Storm Collar and the flashing! Skip down to instruction 1.18.

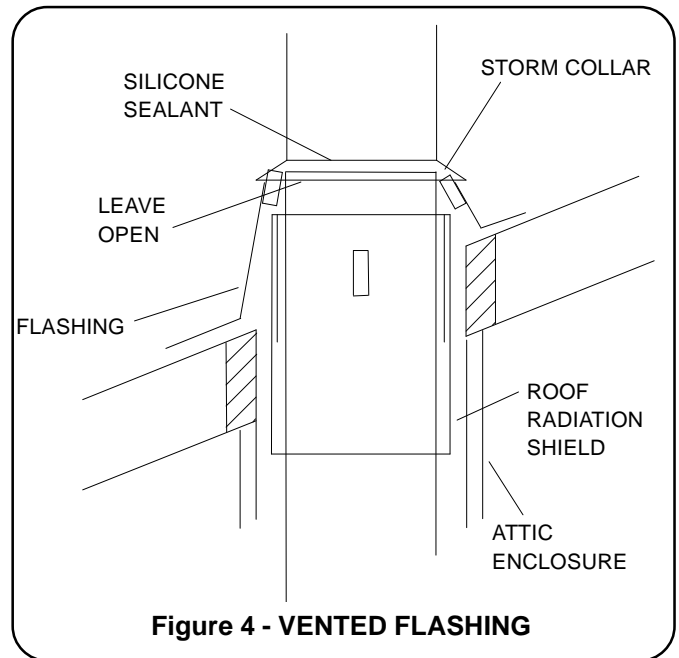

UNOCCUPIED ATTIC SPACE:

If the attic space is unoccupied, the following instructions must be followed. See additional instructions under Canada Applications.

- 1.14. In an unoccupied attic space, an Attic Insulation Shield is required atop the Firestop Radiation Shield or Black Ceiling Support where the chimney enters the attic space. The Shield will keep insulation at the required clearance from the chimney. Slide the shield down over the chimney until it sits on top of the joist level. See Figure 1.
- 1.15. Slide the flashing over the chimney until it sits on the roof line. Slip the upper side of the Flashing base under the roof shingles and lay the lower side over the shingles. Nail the flashing to the roof with a minimum of 8 roofing nails. Seal the Flashing base with appropriate roofing mastic.

- 1.16. Slide the Storm Collar down the chimney until it sits on the Flashing. Tighten the collar's clamp screw. Apply a bead of silicone around the top of the Storm Collar.
- 1.17. Set the Rain Cap onto the top Chimney section and twist lock it to the top Chimney section. See Diagram 1.

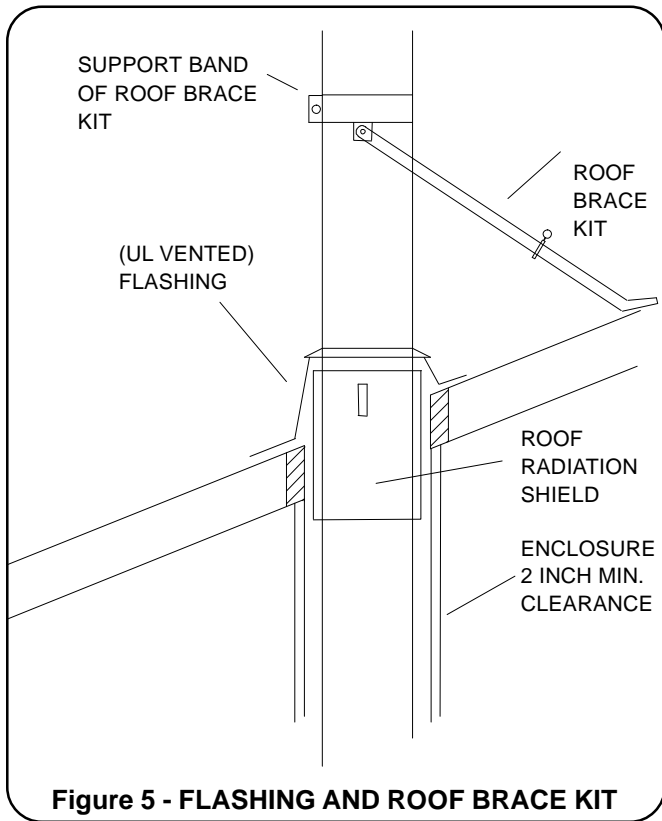

- 1.18. Where the chimney system penetrates the air/vapour barrier, the barrier must be sealed to the ceiling support or firestop radiation shield.
- 1.19. If the Chimney extends five feet or more above the roof penetration, a Roof Brace Kit must be used to provide lateral support. See Figure 5.

2. OFFSET INTERIOR CHIMNEY

If a straight vertical chimney installation is not practical because of interfering joists, etc., an offset is allowed as illustrated. Pairs of 15 or 30 degree elbows are used to make the offset. A maximum of one 36" length is allowed between the elbows. See Chart below and Figure 6.

Elbow Offset Chart				
4" Size	15° OFFSET		30° OFFSET	
Lengths	Offset	Rise	Offset	Rise
none	1.3	9.3	2.7	10.3
6" length	2.6	13.7	5.2	14.6
12" length	4.1	18.9	8.2	19.8
18" length	5.7	24.1	11.2	25.0
24" length	7.2	29.2	14.2	30.2
36" length	10.4	39.6	20.2	40.6

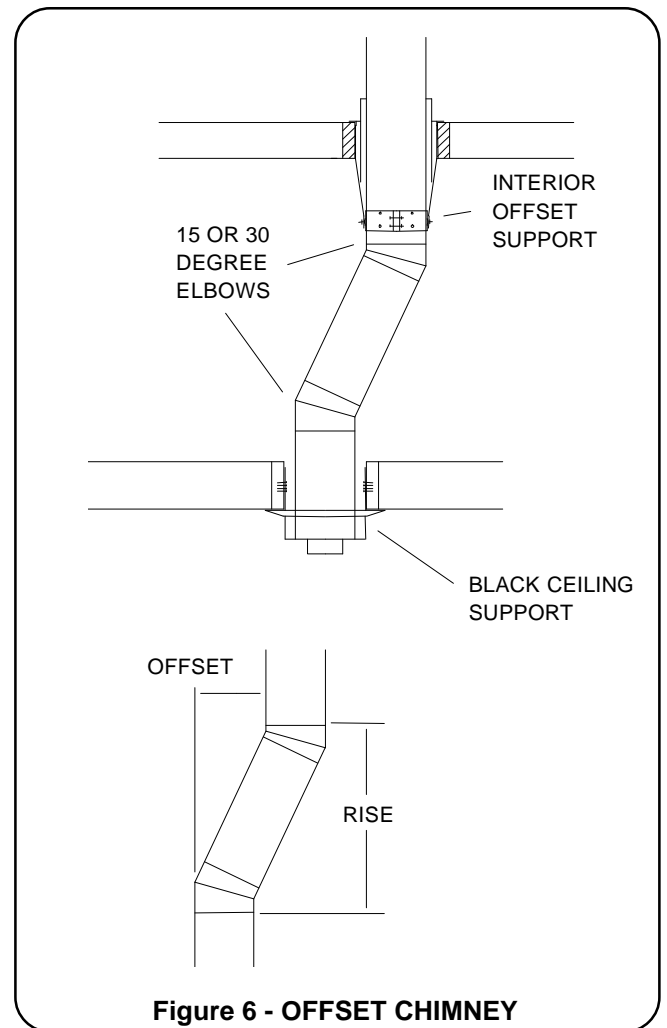

- 2.1. Use the same procedures as for straight chimney (1.1 to 1.19) with the following exceptions.
- 2.2. Set the first Elbow on the vertical Chimney below it and align it for the desired offset. Fasten the Elbow with four #8 x 1/2" screws

3. WALL SUPPORT INSTALLATION

For through-the-wall exterior chimney installations, an insulated Tee and Wall Support Kit are used.

- 3.1. A Wall Support Kit will support up to 50 feet of chimney.

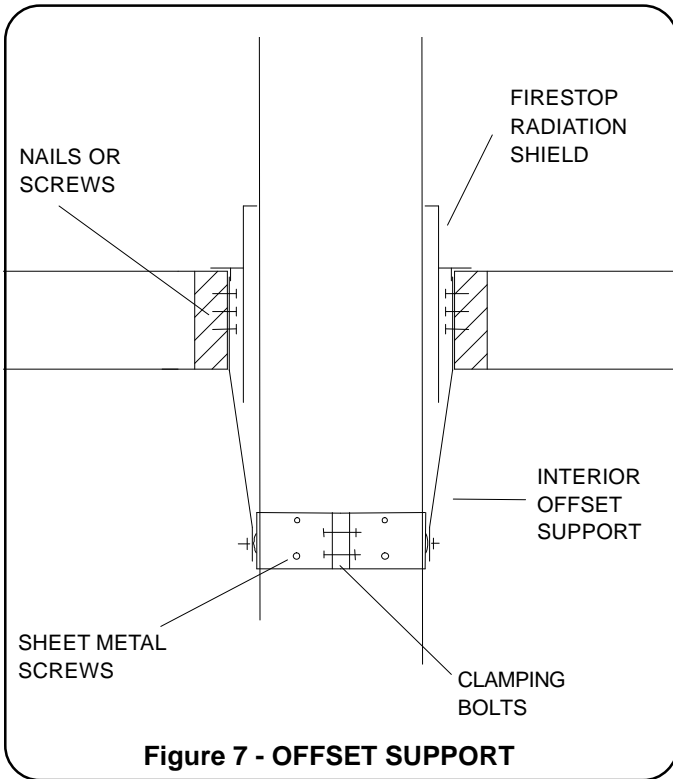

Figure 7 - OFFSET SUPPORT

(provided) through the pre-punched holes in the female end.

- 2.3. Twist lock the inclined Chimney section to the first Elbow and secure it with two #8 x 1/2" screws.
- 2.4. Join the second Elbow to the inclined section and again fasten it with four screws.
- 2.5. Ensure that clearances to combustible material as required by chimney and appliance installation manuals are maintained.
- 2.6. An Interior Offset Support must be used above the second elbow. The IOS will support up to 25 feet of chimney above the second elbow. If additional chimney height is required, use additional IOS at vertical intervals not exceeding 25 feet. fit the band around the Chimney and fasten it by tightening the two clamping screws. Additionally, insert eight #8 x 1/2" screws (provided) through the band's pre-punched holes and into the Chimney skin. Secure the 4 straps of the IOS to joists. Use a minimum of three 1.5" spiral nails or screws per strap. Nails should be loaded in shear, not in tension. See Figure 7.
- 2.7. Floor, ceiling and roof penetrations are the same as for the Ceiling Supported Chimney (section 1.0).

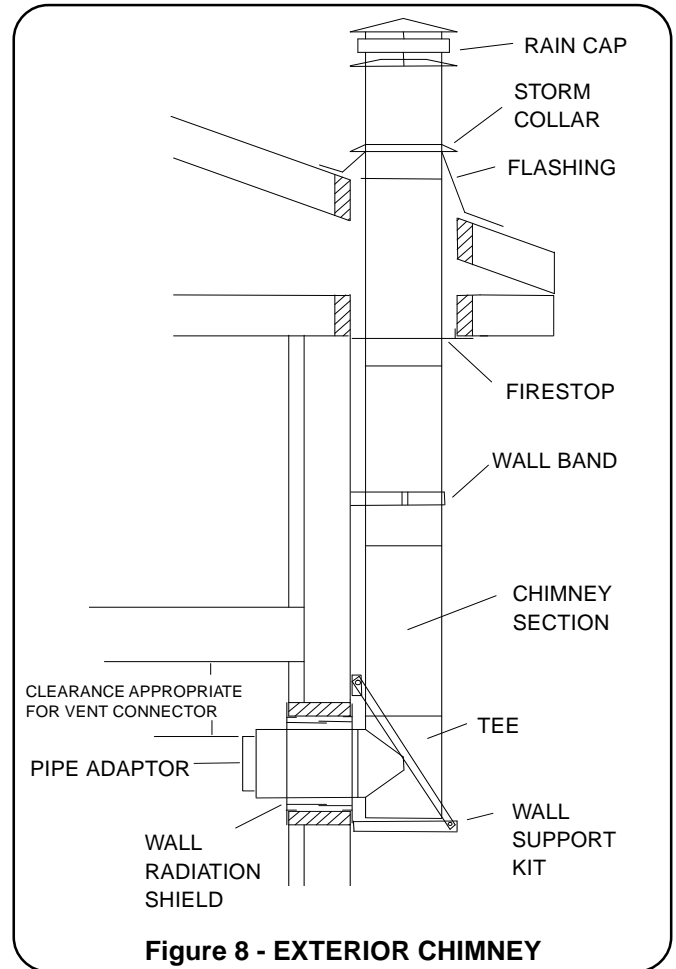

Figure 8 - EXTERIOR CHIMNEY

- 3.2. From inside the house, cut a hole through the wall. Remember to maintain clearance between the ceiling and Chimney connector pipe. See Figure 8.
- 3.3. Frame the hole to provide 2" clearance to all sides of the Chimney skin.
- 3.4. From inside the wall, install the interior portion (painted black) of the Wall Radiation Shield in the hole and nail it in place. Seal the surrounding air/vapour barrier to trim collar of the WRS using an appropriate caulking compound. From outside the wall, install the exterior portion (vented) of the WRS in the hole and nail it in place. Caulk the joint between the WRS and the wall to prevent moisture entry. If the wall is less than 7.5" thick, the radiation shield may be cut shorter, however

tubes must overlap at least 1/2" when installed.

- 3.5. If the wall being penetrated is non-combustible, the Wall Radiation Shield may be omitted and the Chimney installed at zero clearance to the wall material.
- 3.6. Assemble the Wall Support Kit according to instructions packaged with the kit.
- 3.7. From outside the wall, hold the Tee and Wall Support Kit in place and mark lag screw pilot hole locations. NOTE: WSK LAG SCREWS MUST BE DRIVEN INTO WALL FRAMING.
- 3.8. Drill marked holes in the wall and install the Wall Support Kit using six 1/4" x 2" lag screws (not supplied) or anchors appropriate for the wall material.
- 3.9. Place the Tee on the Wall Support Kit and align the Tee branch with the hole through the WRS.
- 3.10. Insert a chimney section through the WRS and twist lock it to the Tee. Chimney section must project into the room at least 6" if the interior wall is combustible. See Figure 9.
- 3.11. Twist lock a pipe adapter into the horizontal Chimney section.
- 3.12. Install additional lengths of Chimney atop the Tee. Twist lock sections together and secure the joints with the provided #8 x 1/2" screws through the pre-punched hole in the Chimney.

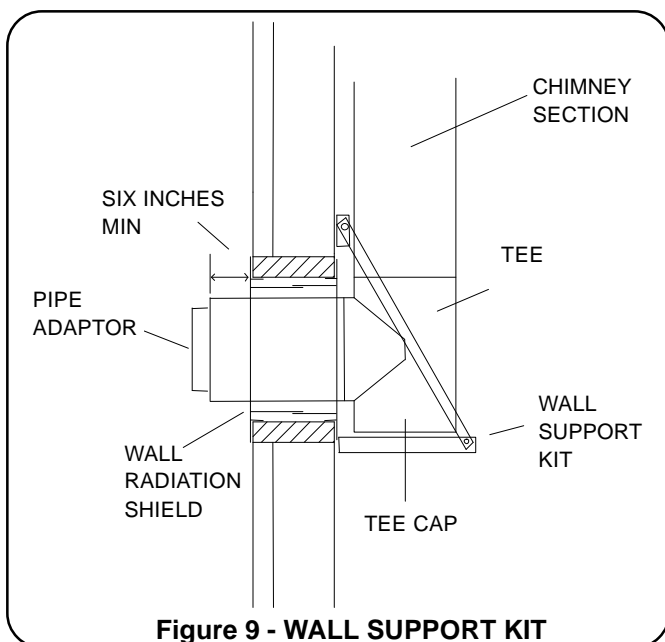

Figure 9 - WALL SUPPORT KIT

- 3.13. Provide lateral support to the Chimney by installing Wall Bands at least every six feet of Chimney rise. Clamp the Bands around the Chimney and secure them to the wall with 1.5" spiral nails or screws.
- 3.14. If you must cut through a roof overhang, remember that the hole must leave a 2" clearance around the Chimney.
- 3.15. Install sections of Chimney up through the roof and fit the Flashing, Storm Collar, and Rain Cap as described in instructions 1.10 to 1.19.
- 3.16. An exterior chimney may optionally be enclosed by a non-insulated chase provided the chase is terminated with a Vented Flashing and Flashing Radiation Shield. Maintain appropriate clearances to combustibles, minimum 2". The chase must provide a means of access to the chimney to facilitate inspection and cleaning.

4. LONG CEILING SUPPORT INSTALLATION

A Long Ceiling Support is used to support a chimney installed in a cathedral ceiling of where a Black Ceiling support is not long enough. See Figure 10.

- 4.1. A long Ceiling Support will support up to 50 feet of chimney.
- 4.2. From inside the roof, mark the center of the roof penetration by driving a nail through to the exterior roofing material.
- 4.3. Take the Long Ceiling Support up on top of the roof and turn it upside down to mark the hole location. Use a spirit level to keep the support vertical while the perimeter of the required hole is marked.
- 4.4. Drill some guide holes along the holes perimeter line. Make sure the holes are vertical, not perpendicular to the roof line.
- 4.5. Use a reciprocating saw or key hole saw to cut the hole. Keep the saw vertical.
- 4.6. Frame the hole with 1 1/2" thick lumber. Position the Long Ceiling Support in the hole and fasten with at least twelve - 1.5" spiral nails or wood screws.
- 4.7. Trim the Support flush with the roof.

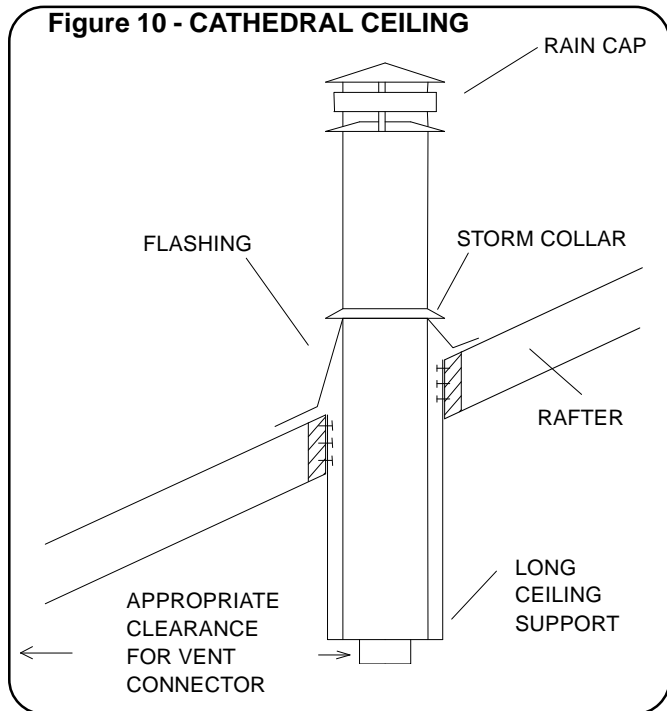

- 5.1. The chimney must be inspected at least every two months during the heating season to determine if a creosote or soot build up has occurred. If creosote or soot has accumulated, it should be removed to reduce the risk of chimney fire.
- 5.2. Do not use a metal or wire brush to clean this chimney. Such a brush may scratch the chimney liner and promote corrosion.
- 5.3. Do not use chemical cleaners to remove creosote from chimney liner. Such cleaners can be corrosive to the chimney and appliance.
- 5.4. It is advisable to clean the chimney at the end of the heating season. Chimney deposits will have their most corrosive effect during humid summer weather.
- 5.5. The chimney is the engine of a natural draft system. The appliance will not burn efficiently if the chimney is not drafting properly.
- 5.6. Some warning signs that your chimney or wood heat system are not operating properly:
 - rapid accumulation of creosote or soot
 - creosote or condensation dripping from chimney base
 - sluggish drafting
 - stains on the outer case of chimney

- 4.8. Seal the body of the Support to the finished ceiling to maintain the air/vapour barrier.
- 4.9. A field fabricated trim collar may be used to provide a finished appearance at the ceiling.
- 4.10. Chimney is installed in the support as described in instructions 1.1 to 1.19.

5. MAINTENANCE AND CLEANING INSTRUCTIONS
Creosote and Soot - Formation and Need for Removal.

When wood is burned slowly, it produces tar and other organic vapours, which combine with expelled moisture to form creosote. The creosote vapours condense in the relatively cool chimney flue of a slow-burning fire. As a result, creosote residue accumulates on the flue lining. When ignited, creosote makes an extremely hot fire.

- 5.7. If a chimney fire is suspected, immediately close all appliance draft controls and dampers including fireplace doors. Keep a close watch on the chimney. If there is any doubt of the severity of the fire, call the fire department. Do not burn the heating appliance again until the appliance and chimney have been thoroughly inspected by a professional. If there is ever a need to slow the intensity of a fire, do not put water on it! The resulting steam can be very dangerous. Instead, put ashes, sand or baking soda on the fire. This will safely smother the fire.
- 5.8. The following materials should not be burned in your wood heat appliance: pressure treated lumber, rail road ties, saltwater driftwood, plastics, or garbage. Burning such materials may lead to severe corrosion of your appliance and chimney.

Leave with homeowner. Homeowner: Keep in a safe place for future reference.

PRODUCT INFO

CHIMNEY MODEL : **4” Ultra-Temp**

FLUE SIZE _____

TOTAL HEIGHT _____

INSIDE INSTALLATION OUTSIDE INSTALLATION

CONNECTED TO (type of appliance):

- BOILER
- FURNACE
- LISTED FACTORY-BUILT FIREPLACE
- OTHER (specify) _____

LOCATION OF APPLIANCE:

- BASEMENT
- MAIN FLOOR
- OTHER (specify) _____

INSTALLATION DATE: _____

DEALER INFO

DEALER NAME: _____

Address: _____

City: _____

Province: _____

TECHNICIAN INFO

TECHNICIAN NAME: _____

Address: _____

City: _____

Province: _____