

# ULTRA-TEMP™

(5" to 10" dia.)  
FACTORY-BUILT  
INSULATED CHIMNEY



Tested to Standard  
CAN/ULC-604  
&  
ULC/ORD-C959

*Installer: It is of the utmost importance that these UT instructions are left with the homeowner.*

*Homeowner: Keep these instructions and maintenance guide in a safe place for future reference.*

**A MAJOR CAUSE OF VENT RELATED FIRES IS FAILURE TO MAINTAIN REQUIRED CLEARANCES (AIR SPACES) TO COMBUSTIBLE MATERIALS.**

**IT IS OF THE UTMOST IMPORTANCE THAT THIS CHIMNEY SYSTEM BE INSTALLED ONLY IN ACCORDANCE WITH THESE INSTRUCTIONS.**

**PLEASE READ ALL INSTRUCTIONS BEFORE BEGINNING YOUR INSTALLATION. FAILURE TO INSTALL THIS SYSTEM IN ACCORDANCE WITH THESE INSTRUCTIONS WILL VOID THE CONDITIONS OF CERTIFICATION AND THE MANUFACTURER'S WARRANTY.**



SELKIRK CANADA INC.  
P.O. BOX 526, DEPOT 1  
Hamilton, ON L8L 7X6  
1-888-SELKIRK (735-5475)  
www.selkirkcorp.ca  
cscanada@selkirkcorp.com

# TABLE OF CONTENTS

CERTIFICATION LABELS .....	3
FUELS AND APPLIANCES.....	4
RULES FOR SAFETY DURING INSTALLATION.....	4
GENERAL INSTALLATION RULES.....	4
TOOLS.....	5
CHIMNEY SIZING.....	5
FRAMING DETAILS.....	5
CEILING SUPPORT .....	5, 6
ADJUSTABLE LENGTH.....	6, 7
ADJUSTABLE ATTIC INSULATION SHIELD .....	7
FIRESTOP JOIST SHIELD.....	8
ELBOW INSTALLATION.....	8
ADJUSTABLE WALL SUPPORT.....	9, 10, 11
WALL BAND.....	11
CATHEDRAL CEILING SUPPORT .....	11, 12
ROOF SUPPORT .....	12
ROOF FLASHING .....	12, 13
UNIVERSAL ROOF BRACE KIT .....	13, 14, 15
ROUND TOP AND SPARK ARRESTER.....	15
STOVE PIPE ADAPTER.....	16
ANCHOR PLATE .....	16
CHIMNEY OPERATION AND MAINTENANCE.....	16
OFFSET CHART.....	17
CHIMNEY CHART ABOVE ROOF.....	18
REPLACEMENT PARTS LIST.....	19
WARRANTY DOCUMENT .....	20
PRODUCT AND INSTALLATION INFORMATION.....	21

# CERTIFICATION LABELS

	FACTORY BUILT CHIMNEYS FOR RESIDENTIAL TYPE AND BUILDING HEATING APPLIANCE CHIMNEY PART	/	CHEMINÉE PRÉFABRIQUÉE POUR APPAREIL DE CHAUFFAGE DE TYPE RÉSIDENTIEL D'IMMEUBLE	
	LISTED TO / INSCRIT À: USA: UL 103 TYPE HT (4"-8"); UL 103 (10"-24") CANADA: CAN/ULC 604 (4"-24") AND ULC/ORD 959 (16"-24")		MODEL/MODÈLE <b>UT / GT / ST / TLC(10"-14")</b>	
2" MINIMUM CLEARANCE AIR SPACE TO COMBUSTIBLE MATERIALS AND BUILDING INSULATION OR AS ESTABLISHED BY FACTORY SUPPLIED SPACERS AND SUPPORT ASSEMBLY. WARNING! INSTALL AND USE ONLY IN ACCORDANCE WITH THE MANUFACTURERS INSTALLATION INSTRUCTIONS PACKED WITH THE SUPPORT ASSEMBLY. FAILURE TO FOLLOW THE INSTALLATION INSTRUCTIONS COULD CAUSE RISK OF FIRE, CARBON MONOXIDE POISONING OR DEATH. TESTED TO STANDARDS UL 103 IN THE USA FOR CONNECTION TO SOLID FUEL, GAS OR OIL BURNING APPLIANCES NORMALLY PRODUCING FLUE GASES OF 1000°F (540°C) OR LESS IN THE USA. ALSO, LISTED TO CAN/ULC 604 IN CANADA FOR CONNECTION TO GAS OR OIL APPLIANCES NORMALLY PRODUCING FLUE GASES OF 540°C (1000°F) OR LESS. SUITABLE FOR USE WITH SPECIFIC FACTORY BUILT FIREPLACES WHERE SPECIFIED IN THE FIREPLACE MANUFACTURERS INSTALLATION INSTRUCTIONS SUITABLE FOR INTERIOR OR EXTERIOR INSTALLATION.			2" DÉGAGEMENT MINIMUM PAR RAPPORT AUX MATÉRIAUX COMBUSTIBLES ET À L'ISOLATION DU BÂTIMENT OU TEL QU'ÉTABLI PAR LES ESPACEURS FOURNIS PAR L'USINE ET L'ASSEMBLAGE DE SUPPORT. AVERTISSEMENT! INSTALLER ET UTILISER UNIQUEMENT CONFORMÉMENT AUX INSTRUCTIONS D'INSTALLATION ET D'ENTRETIEN EMBALLÉ AVEC L'ENSEMBLE DE SUPPORT. LE NON-RESPECT DES INSTRUCTIONS D'INSTALLATION POURRAIT PROVOQUER UN RISQUE D'INCENDIE, D'EMPOISONNEMENT AU MONOXYDE DE CARBONE OU LA MORT. TESTÉ SELON LES NORMES UL 103 AUX ÉTATS-UNIS POUR LE RACCORDEMENT À DES APPAREILS À COMBUSTIBLE SOLIDE, AU GAZ OU AU MAZOUT PRODUISANT NORMALEMENT DES GAZ DE COMBUSTION DE 1000 °F (540 °C) OU MOINS AUX ÉTATS-UNIS. ÉGALEMENT, RÉPERTORIÉ À LA CAN/ULC 604 AU CANADA POUR LE RACCORDEMENT À DES APPAREILS À GAZ OU À HUILE PRODUISANT NORMALEMENT DES GAZ DE COMBUSTION DE 540 °C (1000 °F) OU MOINS. CONVIENT À UNE UTILISATION AVEC DES FOYERS SPÉCIFIQUES FAITS EN USINE OÙ SPÉCIFIÉ DANS LES INSTRUCTIONS D'INSTALLATION DU FABRICANT DE FOYER. CONVIENT À UNE INSTALLATION INTÉRIEURE OU EXTÉRIEURE.	
HART & COOLEY GRAND RAPIDS, MI	SELKIRK CANADA INC. HAMILTON, ON		SELKIRK CORPORATION GRAND RAPIDS, MI	LV

	RESIDENTIAL TYPE AND BUILDING HEATING APPLIANCE CHIMNEY COMPONENT	PIÈCE COMPOSANTE POUR APPAREIL DE CHAUFFAGE DE TYPE RÉSIDENTIEL D'IMMEUBLE
	LISTED TO / INSCRIT À: USA: UL 103 TYPE HT (4"-8"); UL 103 (10"-24") CANADA: CAN/ULC 604 (4"-24") AND ULC/ORD 959 (16"-24")	
MODEL/MODÈLE <b>UT / ST / TLC(10"-14")</b>		
INSTALL AND USE ONLY IN ACCORDANCE WITH INSTALLATION AND MAINTENANCE INSTRUCTIONS. SUITABLE FOR INTERIOR OR EXTERIOR INSTALLATION.		
INSTALLER ET UTILISER UNIQUEMENT CONFORMÉMENT AUX INSTRUCTIONS D'INSTALLATION ET D'ENTRETIEN. CONVIENT À UNE INSTALLATION INTÉRIEURE OU EXTÉRIEURE.		
HART & COOLEY GRAND RAPIDS, MI	SELKIRK CANADA INC. HAMILTON, ON	SELKIRK CORPORATION GRAND RAPIDS, MI
LV	MADE IN / FABRIQUÉ AU CANADA NP386 REV. 00	

If you are knowledgeable in carpentry and mechanically inclined, you can take on the task of installing your new venting system. It is important that all pertaining installation instructions and local codes are followed carefully. If you have any doubt concerning your ability or knowledge of the appliance being connected to your chimney system, arrange for a professional installation. Certified technicians having installed systems many times before and have the knowledge and experience to perform your installation in a professional and timely manner.

### **FUELS & APPLIANCES:**

Model UT chimney has been designed as gravity venting only if the appliance operates with neutral or negative draft at its outlet. Any positive pressure in the chimney should use a Selkirk Model PS or IPS system. Model UT has been designed for connection to liquid or gas fired residential type appliances and building heating appliances, in which normally producing flue gas temperatures of 540° C (1000° F) or less.

All diameters (5", 6", 7", 8", and 10") comply fully with the requirement of CAN/ULC-604. Model UT 10" comply also to the requirements of ULC/ORD-C959 the 540° and 760° Industrial Chimney Standard.

May also be used with specific factory-built fireplaces listed to UL 127 and CAN/ULC-S610 when specified in the fireplace manufacturer's certified installation instructions.

Before commencing the installation ensure that you obtain any necessary building permits, and that your installation will conform with all federal and municipal building codes requirements affecting the fuel-burning appliance and its chimney. This chimney is intended for use in accordance with:

- National and Provincial Building Code of Canada,
- CAN/CSA B-149.1-00 Installation Code for Gas Equipment,
- CAN/CSA B-139.00 Installation Code for Oil Burning Equipment;
- Appliance and venting manufacturers's Installation Instructions.

**Do not place any type of insulating materials or run any electrical wiring within the required clearance air space surrounding the chimney.**

### **RULES FOR SAFETY DURING INSTALLATION:**

- Be very careful around electrical wiring and be sure it is secured at least 2 inches away from any part of the chimney. If wiring must be relocated, hire a professional electrician.
- Be sure that electrically powered tools are properly grounded.
- Be sure that ladders are in good condition and always rest on a level firm surface.

**WEAR SAFETY GLOVES WHEN HANDLING SHEET METAL PARTS WITH SHARP EDGES**

### **GENERAL INSTALLATION RULES:**

The chimney should be located within the building so as to avoid cutting or altering load bearing members such as joists, rafters, studs, etc. If you require to cut or alter an existing load bearing member, special reframing methods are required which often include doubling of adjacent members. If such a case arises, contact your local Building Code Official regarding local regulations and proper installation methods.

The chimney pipe and fittings must be assembled with locking bands or stainless sheet metal screws, maximum length of 1/2" (12.70mm) on all interior joints. Locking bands must be used on all exterior joints.

Do not mix and match with other manufacturer's products. Use only UT listed components.

Support all offsets with an offset support and adequate strapping.

Attach flue pipe parts securely to each other, and to the appliance using three sheet metal screws per joint.

**Model UT chimney requires 2" (50mm) clearance to combustible material or as established by support assembly.**

The minimum clearance to Model UT means AIR SPACE ONLY. The 2 inch (50mm) clearance to pipe, and the spaces around supports must not be filled with any type of insulation.

An Adjustable Attic Insulation Shield (AAIS) must be installed where the chimney passes from a lower living space into an open attic space. It is designed to keep insulation materials or debris from coming into contact with the chimney outer wall. Certain insulations made of cellulose fiber (old newspapers, processed wood) may ignite and smolder due to heat trapped by contact with the chimney. When this smoldering fire reaches ordinary wood framing, a smoldering fire may create noxious gases and cause great property damage.

Where height restrictions will not permit the use of the Adjustable Attic Insulation Shield, it is permissible to construct an enclosure with a 2" air space clearance to the outer pipe all the way to the underside of the roof deck. In this application you would install a Firestop Joist Shield on the ceiling side.

At the level where the chimney penetrates the air/vapour barrier, special attention is required. Seal the vapour barrier to the Firestop Spacer, Ceiling Support assembly, Adjustable Attic insulation Shield or Wall Thimble using an appropriate caulking compound as per the requirement of local authorities.

Sections of the UT chimney which pass through accessible areas of the building such as closets, storage areas, occupied spaces or anyplace where the surface of the chimney could be contacted by persons or combustible materials **must** be enclosed in a chase to avoid personal contact and damage to the chimney. The chase may be fabricated using standard building materials. Drywall mounted on 2" x 4" studs is typically used in this situation. Except for installation in single and two family dwellings, factory-built chimneys shall be enclosed with approved walls having a fire resistance rating equal or greater than that of the floor, wall or roof assemblies through which they pass. and must have a fire resistance rating equal to or greater than the floors or ceilings through which they pass. The minimum airspace clearance between the outer wall of the chimney and the enclosure shall be at least 2 inches.

The ideal location for your chimney is within the building envelope. In cold climates, the use of external chimneys may result in operational problems such as poor draft, excessive condensation of combustion products and rapid accumulation of creosote. Under these circumstances, the installation of the chimney within the building is strongly recommended.

If the chimney must be installed on an exterior wall it is recommended that the chimney be enclosed below the roof line to protect the chimney from cold outdoor temperatures, this may help reduce condensation, creosote formation and enhance draft. Provide an access door by the Tee Cap for chimney inspection and cleaning. The exterior enclosure may be insulated, maintaining the required 2" (50mm) air space clearance to any part of the chimney. Consult local building codes for cold climate applications.

**YOUR CHIMNEY HAS BEEN TESTED, AND LISTED USING ALL OF THE SUPPORTS, SHIELDS, ETC., DESCRIBED HEREIN. DELETION OR MODIFICATION OR ANY OF THE REQUIRED PARTS OR MATERIALS MAY SERIOUSLY IMPAIR THE SAFETY OF YOUR INSTALLATION, AND VOID THE CERTIFICATION AND OR WARRANTY OF THIS CHIMNEY**

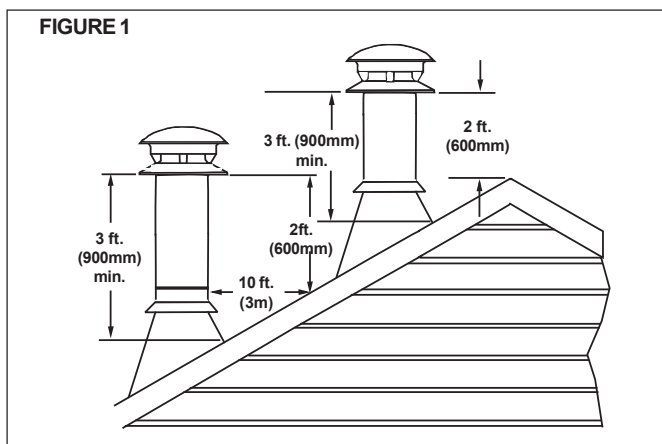
## TOOLS:

Your UT chimney system is designed for installation using standard building materials and procedures. The following tools/equipment may be required as well as some others depending on the location and structure in which the chimney is to be installed:

- Safety gloves
- Safety goggles
- Hammer and nails
- Tin snips
- Tape measure
- Screwdrivers and pliers
- Plumb line and level
- Square
- Keyhole saw or power jig saw
- Caulking gun and caulking

## CHIMNEY SIZING:

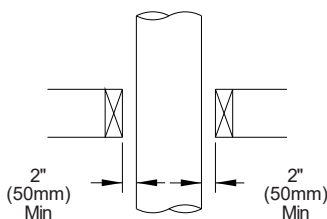
In order to achieve safe, optimum performance of the appliance, service life of the chimney, the chimney should be sized correctly for the connected appliance. In general, the chimney flue should be the same size as the appliance flue outlet. Installations should be done in accordance with the applicable installation codes (eg. CSA-B149 for natural gas and propane appliances, and CSA-B139 for fuel oil appliances) and appliance manufacturer instructions. Plan the installation of your appliance and chimney in such a way that both your chimney and flue pipe runs are as short and straight as possible. By having too long and/or multiple bend installations you can reduce system draft which can affect the operation, and/or performance of your appliance and/or chimney system.



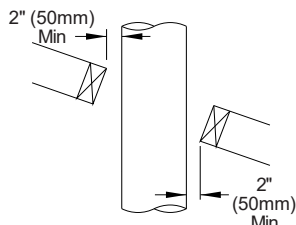
Authority require that the chimney extend not less than 3ft (900 mm ) above the highest point where it passes through the roof of a building and not less than 2ft (600 mm) higher than any portion of a building within 10ft (3m) horizontally. See Figure 1 and Chart 2 in the back of these instructions.

## FRAMING DETAILS:

Plan your installation carefully. If possible, position the appliance so that the flue outlet is centered between joists, rafters or studs. Drop a plumb line to the center of the flue outlet and mark this center point on the ceiling. Lay out and frame all openings ensuring the specified 2" clearance to combustibles is maintained. All openings should be square, plumb and in perfect alignment with each other (see Figure 2). For angled roofs, ensure that the framing dimensions are measured on the horizontal plane (see Figure 3).



**Figure 2**  
**Typical Joist Framing**



**Figure 3**  
**Typical Roof Joist Framing**

Table 1 FRAMING DIMENSIONS FOR MODEL UT TO MAINTAIN 2 INCH AIR SPACE CLEARANCE					
Chimney Inside Diameter:	MODEL UT				
	5"	6"	7"	8"	10"
Ceiling Support*	11 1/4"	12 1/4"	13 1/4"	14 1/4"	16 1/4"
Cathedral Support	12 1/4"	12 1/4"	N/A	N/A	N/A
All other framing*	11"	12"	13"	14"	16"

\*All framing dimensions may be 1/2" larger, but not less than the dimensions mentioned above.

## INSTALLATION PROCEDURES:

### CEILING SUPPORT

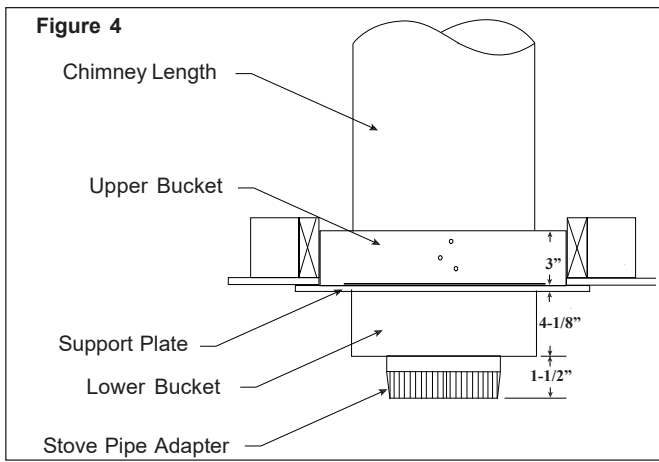
To complete a proper Ceiling Support installation, the following parts may be required. Ceiling Support available only for 5" to 10" diameters.

- Ceiling Support: For joist supported chimney system.
- Attic Insulation Shield: Where a chimney enters an open attic space.
- Firestop Joist Shield: Installed where the chimney passes from one living space to another living space or as specified in the listed factory-built fireplace installation instructions.
- Roof Flashing: Required when the chimney penetrates a roof.
- 15° , 30° or 45° Elbow Kits (2 per box with locking bands and elbow support). NOTE: 45° Elbow kits is available in 5" to 8" only.
- Suitable lengths of chimney: Available in 6", 12", 18", 24" and 36" lengths. A 48" length is available in 6", 7" and 8" only.
- Round Top
- Stove Pipe Adapter

The Ceiling Support is for installation below a finished or unfinished ceilings. The Support fire stop plate fits up against a ceiling, or a joist opening framed level on all four sides.

The following instructions will assist you in the installation of your chimney with a Ceiling Support. This support will hold up to 15.25m (50') of chimney sections, all of which must be installed above the support.

1. Frame a level square opening (all four sides). Inside dimensions should conform to Table 1.
2. With the Lower Bucket removed, place the upper bucket assembly into the framed opening from below.
3. Ensure that the support plate is level and flush and drive one nail, 1-1/2" common or spiral, part way into each of the four (4) nailing areas of the support. You may substitute nails with #8 x 1-1/2" wood screws.
4. Finish nailing through all prepunched holes and fasten the finishing (support) plate to the ceiling (see Figure 4).
5. Replace the Bucket Section from above. Connect the proper sized Stove Pipe Adapter to the first chimney section. Lower this chimney section down into the bucket section, with the male end pointing upwards as indicated by the arrow on the chimney label.
6. Additional chimney lengths above the support are simply stacked on, twist locked with a 1/8 clockwise turn and secured with a locking band at each chimney joint. A locking band is supplied with every chimney length and must be used on all chimney joints, interior or exterior. Stainless steel sheet metal screws (maximum length of 12.70mm (1/2") may be substituted on interior joints.
7. Finish the chimney to its required height.
8. If an offset is installed in the system, an Offset Support must be installed as shown in Figure 13.
9. If the chimney extends 5 feet (1.5 m ) or more above the roof, additional lateral support is required, such as the Universal Roof Brace Kit.



**Warning:** The chimney lengths and its fittings must be assembled with metal-to-metal joints as furnished. Do not use tape or any sealing compound (such as tar, mastic, putty or silicone) at the outer joints. Sealers in the joints may cause the insulation to accumulate moisture and may cause corrosion or freezing failures.

### ADJUSTABLE LENGTH (AL)

An Adjustable Length (AL) is installed between other components to establish an exact finished length, where a standard length can not be utilized. The AL has an over all length of 12" and has an installed length that adjusts from 2" to 9-1/2".

The Adjustable Length is available only in diameters of 5" to 8".

The Adjustable Length must be installed above a fixed length - they cannot be installed immediately above a support, tee or elbow.

The Adjustable Length slides over the male end of an adjoining straight length. However, to allow engagement it is necessary to remove some of the insulation from the inlet end of the Adjustable Length.

**Note:** To facilitate installation, it is recommended that the Adjustable Length be attached and secured to the lower adjoining segment before it is installed in the system.

### To install:

1. Determine (measure) the finished (installed) length of chimney needed (DIM "A") and add 2.25" to the measurement (See Fig. 6a).

2. Remove the Adjustable Length from the packaging carton and set it with the male end (coupler end) of the Adjustable Length down to prevent insulation from spilling out (See Fig. 6b).

3. From the male end, measure up the distance Dim "A" + 2.25" and mark a line on the Adjustable Length (See Fig. 6b).

4. Measure the distance (Dim "B") from that line to the edge of the Adjustable Length and add 1". This is the "overlap" distance. On the adjoining standard length, measure up from the male coupler, the "overlap" distance and mark a reference line. Make sure the location of the reference line is measured from the standard length's male (coupler) end (See Fig 6b).

5. Remove insulation from the inlet (female) end of the Adjustable Length until the insulation is level with the line marked on the outside of the pipe (See Fig. 6b).

6. While still positioned with the coupler end down, insert the standard straight length into the Adjustable Length (See Fig. 6c).

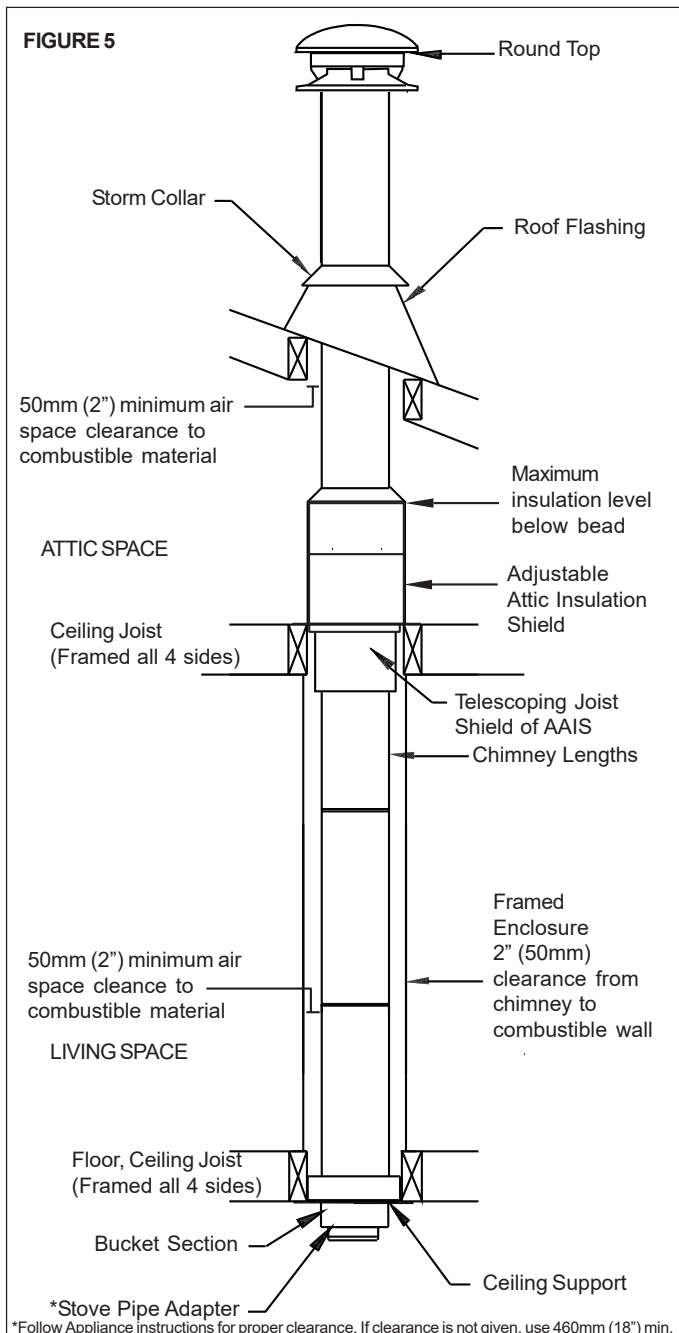
7. Re-orient the assembly to the upright position (Male Coupler Up) and apply pressure to compress the adjoining segments together until the overlapped edge of the Adjustable Length extends down to the reference line marked on the standard length. Secure by installing 3 #8 x 1/2" stainless steel sheet metal screws through the pilot holes in the Adjustable Length and into the outer wall of the adjoining segment (See Fig. 6d).

8. Seal the overlap seam and screws with silicone sealant (See Fig. 8b).

9. Once the female end of the Adjustable Length is secured to the adjoining segment, the assembly may be installed in the system.

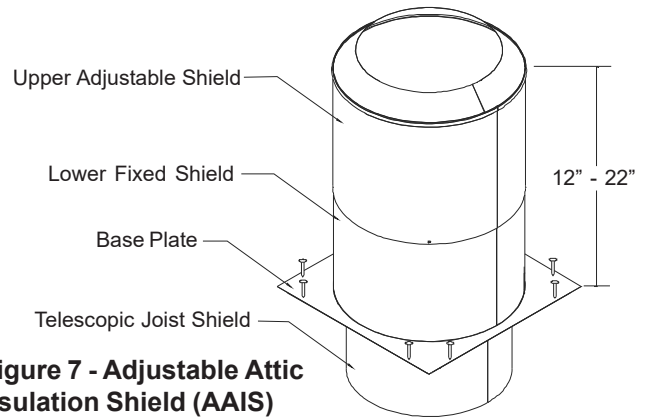
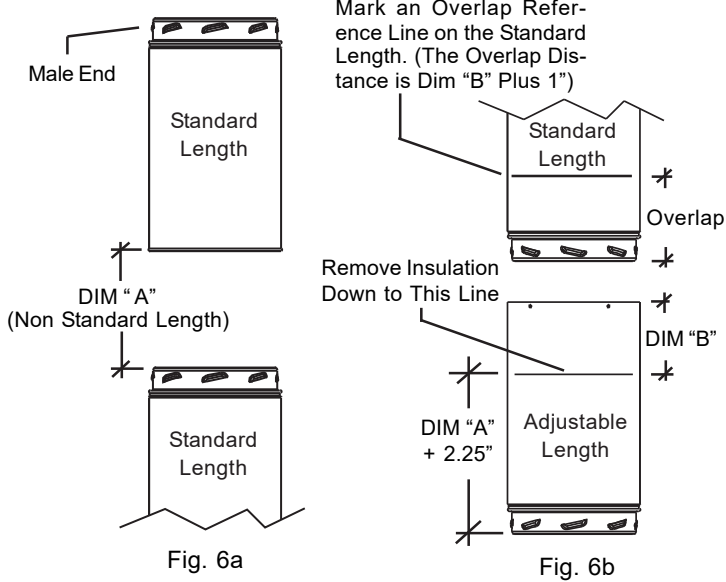
**NOTE:** If the Adjustable Length (AL) is installed in a system where it will be subjected to the weight of more than 4' of chimney (either above or below), supplementary support such as an Interior Resupport (IR) is required.

10. Refer to main installation instructions to continue installing the remaining system parts.



## ADJUSTABLE ATTIC INSULATION SHIELD (AAIS)

The Adjustable Attic Insulation Shield (AAIS) is to keep insulation from coming into contact with the chimney outer wall. It must be installed where a chimney passes from a lower living space into an open attic space. The AAIS consists of a two part shield (top shield adjust over the lower shield) which allows for a depth of insulation from 12" to 22", plus the depth of the ceiling joist with the telescoping joist shield (see Figure 7). The height of the AAIS is to meet the insulation level requirement of the National Building Code.

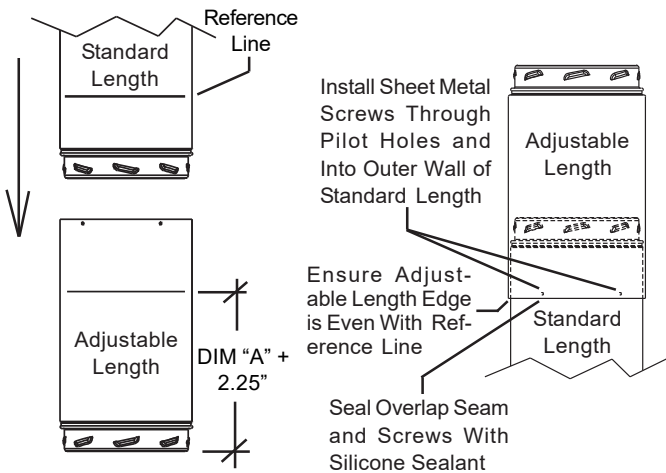


**Figure 7 - Adjustable Attic Insulation Shield (AAIS)**

### To install:

The attic opening should be fully framed on all 4 sides to ensure the required 2 inches air space clearance to the chimney is present as per the Framing Dimensions in Table 2. Framing material is to be of the same stock as the ceiling joists (see Figure 8A).

CHIMNEY DIAMETER	5"	6"	7"	8"	10"
FRAMED OPENING	11" X 11"	12" X 12"	13" X 13"	14" X 14"	16" X 16"



**Fig. 6c**

**Fig. 6d**

6c Insert Standard Length While Oriented as Shown to Avoid Insulation Spillage

Adjustable Length Attached to Standard Length

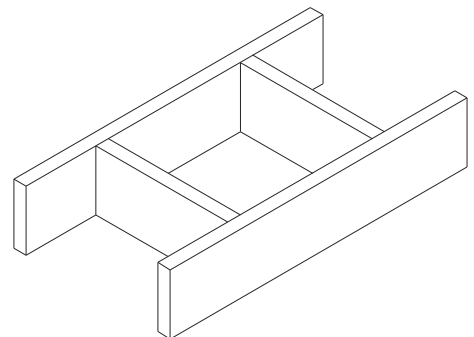
### FIRESTOPPING:

Firestopping is required at every joist level. Wherever a chimney passes through a ceiling or floor, through a wall, or into an enclosure, it must be firestopped. No firestopping is required in conjunction with a Ceiling Support installed as shown in Figure 5, the Ceiling Support provides the firestopping. Firestopping performs the following essential functions for both the dwelling and the chimney.

- Together with a fully framed opening (all four sides), controls vertical and horizontal spread of any fire external to the chimney.
- It stabilizes the chimney in the framed opening and defines and maintains the required AIR SPACE clearance to combustibles.
- It prevents heat losses from the dwelling by blocking vertical air circulation in the space around the chimney.
- It helps provide stability for chimney extending above the roof.
- At the level where the chimney penetrates the air/vapour barrier, special attention is required. Seal the vapour barrier to the Support Assembly or Attic Insulation Shield or Wall Thimble or Firestop using an appropriate caulking compound as per the requirement of local authorities.

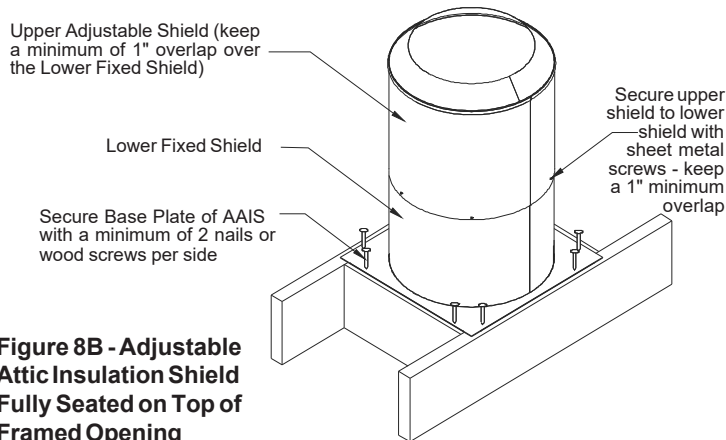
Slide the upper (adjustable) shield up as high as possible (keeping a minimum of 1" overlap on the lower shield). Secure to lower fixed shield using the 4 sheet metal screws provided through the pre-punched holes in the upper shield (see Figure 8B).

Slide the AAIS over the pipe extending into the attic space until the base plate of the AAIS is placed on the framed opening around the chimney and fully seated.



**Figure 8A - Attic opening to be framed on all 4 sides**

Secure the base plate to the framing with at least 2 nails or wood screws per side (see Figure 8B). Ensure the spacers found under the base plate are within the framed opening.



**Figure 8B - Adjustable Attic Insulation Shield Fully Seated on Top of Framed Opening**

The upper shield can be trimmed down to ensure the AAIS will fit in a low clearance area in the attic at the soffit end. Ensure the top of the shield is 2" higher than the level of insulation and it overlaps 1" on the lower fixed shield.

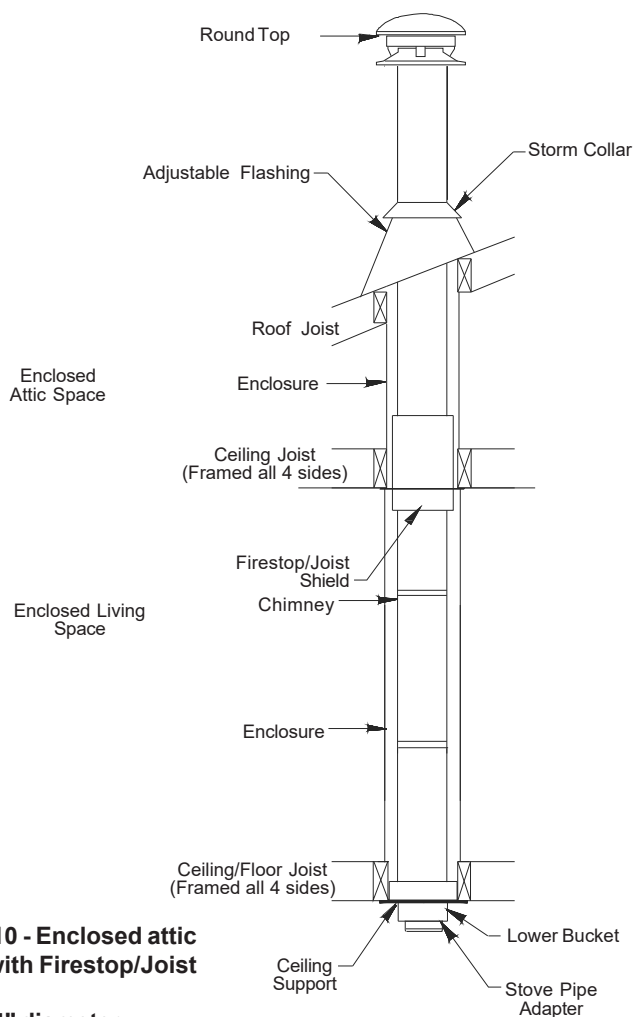
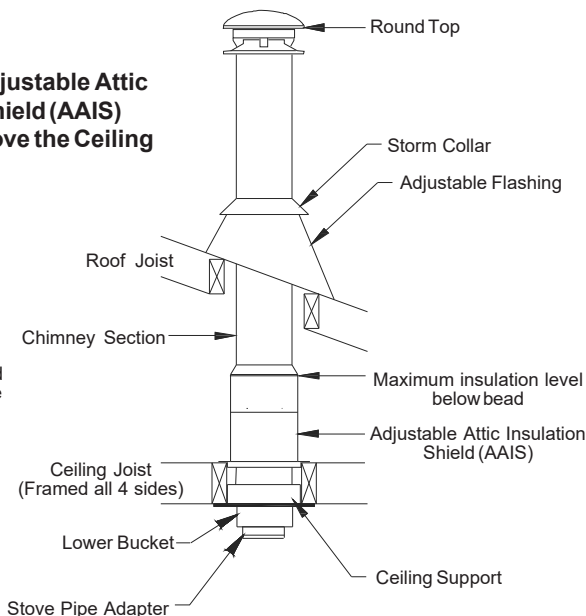
If greater height restrictions do exist, it is permissible to enclose the chimney in the attic space by installing the Firestop/Joist Shield (JS) at the ceiling level. The enclosure must maintain the required minimum air space clearance of 2" (50mm) to the chimney pipe all the way to the underside of the roof deck (see Figure 10).

If insulation is blown in and adheres to the chimney pipe, it should be brushed off to eliminate any possible contact of this material with the chimney when it is in use.

The lower telescoping joist shield will sit inside of the Ceiling Support (see Figure 9) or extend below the ceiling joist (see Figures 5, 13). Ensure it is properly extended down through this area.

NOTE: It is permissible to add Universal Insulation Shielding (SUSI) in the Adjustable Attic Insulation Shield (AAIS) to reduce cold air infiltration into the dwelling. See instructions supplied with the Universal Insulation Shielding.

**Figure 9 - Adjustable Attic Insulation Shield (AAIS) installed above the Ceiling Support**

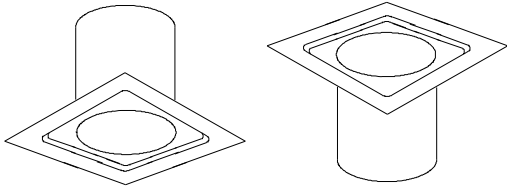


**Figure 10 - Enclosed attic space with Firestop/Joist Shield**  
**NOTE: 4" diameter chimney requires a Firestop Radiation Shield installed at the roof level.**

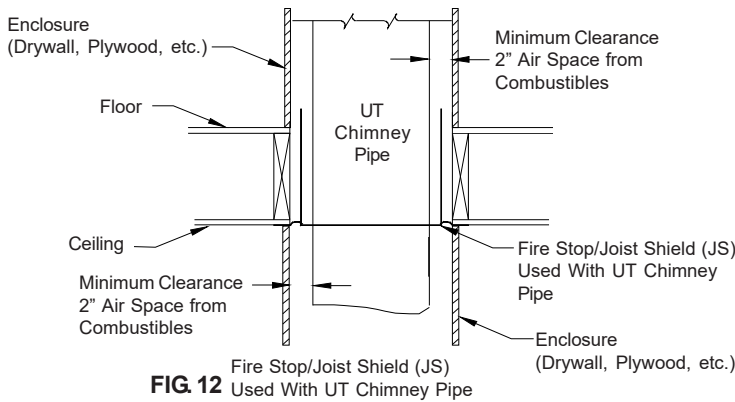
## FIRESTOP JOIST SHIELD

A Firestop Joist Shield is for use in vertical enclosures where the chimney passes through a floor / ceiling opening, from one living space to another living space. It is installed from either above or below the joist. Nail the Firestop Joist Shield using 1-1/2" common or spiral nails, into the framed opening outlined in Table 1.

Enclose the chimney below the Fire Stop Joist Shield to prevent any accidental contact with the chimney. To prevent blown-in attic insulation from falling against the chimney, either use an Attic Insulation Shield (AIS) or a full enclosure in the attic. See Section on Attic Insulation Shield.



**FIG 11**  
Firestop/Joist Shield (JS)  
Used With UT Chimney



**FIG 12**  
Fire Stop/Joist Shield (JS)  
Used With UT Chimney Pipe

## ELBOW INSTALLATION

Elbow Kits (2 elbows, 1 offset support and 2 locking bands).

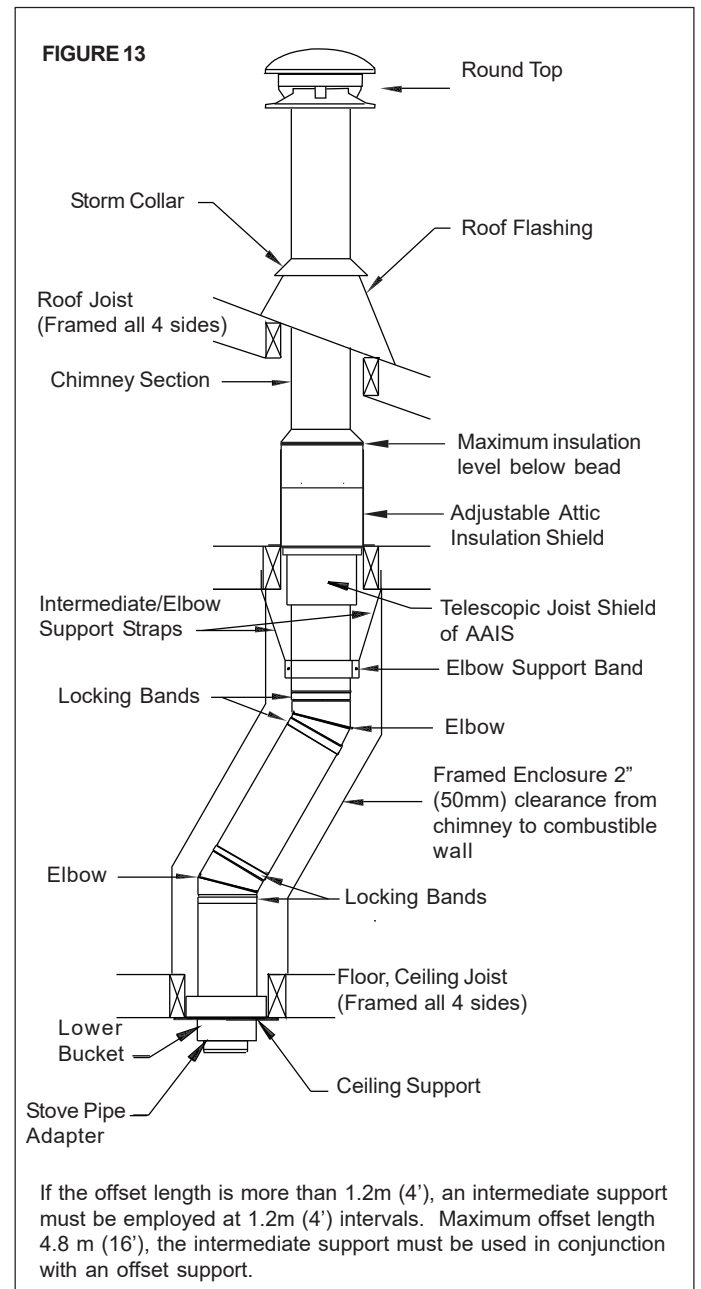
Table 3	MODEL UT				
	5"	6"	7"	8"	10"
15° Elbow Kit	X	X	X	X	X
30° Elbow Kit	X	X	X	X	X
45° Elbow Kit		X	X	X	

One pair only of (two) 15 or 30 or 45 degree elbows may be used to provide an offset in order to avoid cutting of joists and to clear other obstructions (see Table 3). The vertical run of chimney above an offset must be supported with an elbow support. Each elbow support will support 10m (30') of chimney. If the offset length is more than 1.2m (4'), an intermediate support (plumbing straps not supplied) must be installed at 1.2m (4') intervals in conjunction with an offset support. Maximum offset length is 4.8m (16'). See the Offset Chart for assistance in selecting your offset. NOTE: 10 diameter may combine elbow kits for a greater angle up to 45°.

The female end of the elbows are not **lanced** in order to ensure proper alignment of the chimney system can be maintained.

Install and position the insulated elbow on the vertical chimney length in the required direction. Fasten the elbow to the chimney length with the supplied locking band.

Place the required offset chimney length(s) (see Offset Chart for appropriate length(s)) on the elbow. Turn it clockwise to lock it in place



and install the supplied locking band.

Install the remaining offset elbow to return the chimney back to the vertical position. Again secure in place with the supplied locking band. \*Locking bands and/or stainless steel sheet metal screws can be utilised with a maximum length of 12.70mm (1/2") only on all chimney joints forming an offset.

During installation provide supplementary support for the offset section to avoid undue stress on connected elbows.

Install an Elbow Support on the vertical length just above the highest elbow. Securely clamp the support band to the chimney length just above the locking band at the joint. Attach the support straps to the support band assembly and nail them to the framing using 1-1/2" nails or #8 x 1-1/2" wood screws (2 per straps) as per Figure 13.

**Never install an elbow in a joist area. Chimney sections must pass vertically through framed joist areas.**

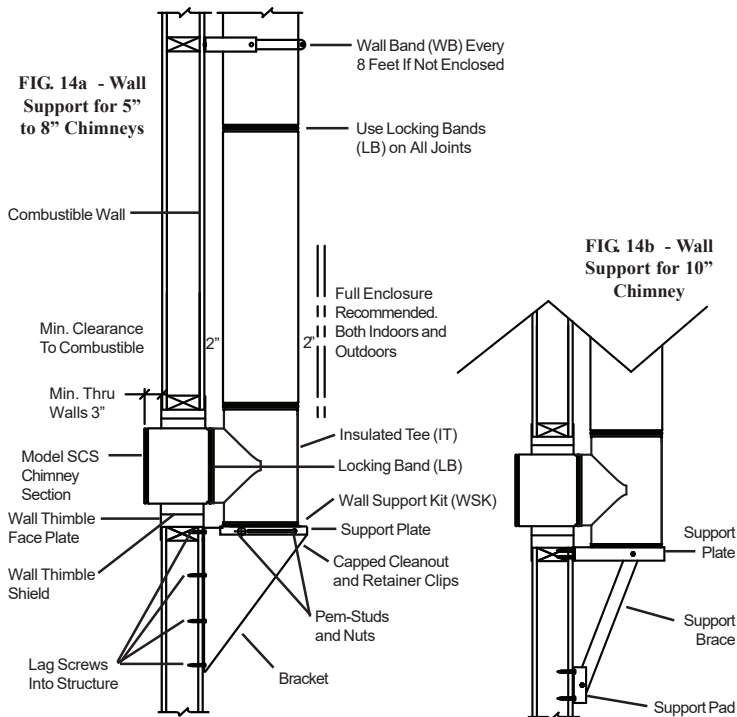
## ADJUSTABLE WALL SUPPORT

As previously mentioned, the ideal location for your chimney system is within the building envelope. An Adjustable Wall Support is required when the above mentioned location is not possible.

The adjustable Wall Support will allow for an adjustment of 2" to 6" from a combustible vertical wall (see Figures 14a and 16). Pem-studs are factory installed on both side brackets and the support plate for fast and easy assembly.

The maximum chimney height above the Wall Support whether supported along an interior or exterior wall is indicated in Table 5 and illustrated in Figure 16.

NOTE: If installing a 10" diameter chimney the Wall Support is a non-adjustable version which comes with support braces and provides a 2" clearance when properly installed. Maximum support height is 50 Feet for 5" through 8" and 40 feet for 10" (see Figs. 14a & b).



If supported along an interior wall in a non-attic area the chimney must be fully enclosed with a minimum of 2" air space clearance. In the attic area the chimney an Attic Insulation Shield is to be installed. The height of the Attic Insulation Shield must accommodate the amount of insulation height as required by the National Building Code. If it is not practical to use the Attic Insulation Shield (due to height restriction), it is permissible to construct an enclosure with a 2" air space clearance to the outer pipe all the way to the underside of the roof deck. Install a Firestop Spacer on the ceiling side.

If supported along an exterior or interior wall, Wall Bands must be installed every 8' to insure chimney stability and maintenance of 2" air space clearance. In any chimney installation, two points of stabilization are necessary hence at least one Wall Band must be installed. It is desirable to fully enclose an exterior chimney with minimum of 2" air space clearance to reduce creosote buildup and to promote draft.

The framing dimensions for the Wall Support are illustrated in Fig. 15 and Table 4.

To complete a proper Wall Support installation, the following parts may be required:

- Adjustable Wall Support: Intended for a through-the-wall installation where the chimney has a horizontal connection.
- Suitable Lengths of chimney: Installed above the support.

SIZE	DIMA	DIMB
5"	11"	9-1/4"
6"	12"	9-1/4"
7"	13"	10-1/4"
8"	14"	11-1/4"
10"	16"	13-1/4"

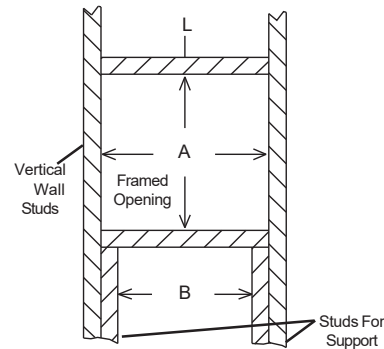


FIG. 15 - Framing for Wall Support

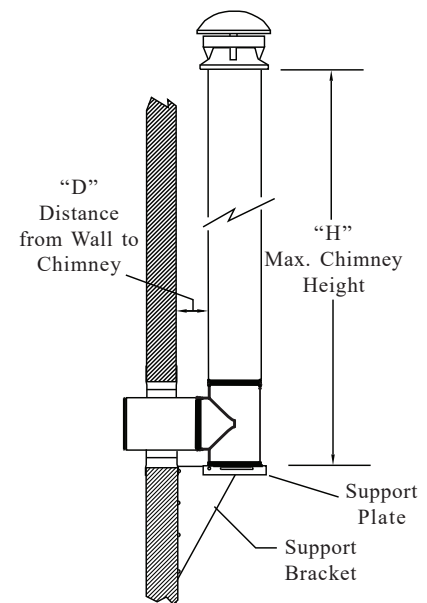


FIG. 16 - See Table 5 for Maximum Chimney Heights based upon Chimney Diameter and Distance from Wall

- Through-The-Wall Length: Attaches to tee branch.
- Insulated Tee w/Plug
- Insulated Wall Thimble: Required to pass through a combustible wall.
- Wall Band: Required to provide lateral support to the chimney.
- Round Top: To prevent rain and/or debris from entering in the chimney.
- Stove Pipe Adapter: To connect from the chimney to appliance's flue pipe.
- Roof Flashing: Required when the chimney penetrates a roof or a roof overhang.

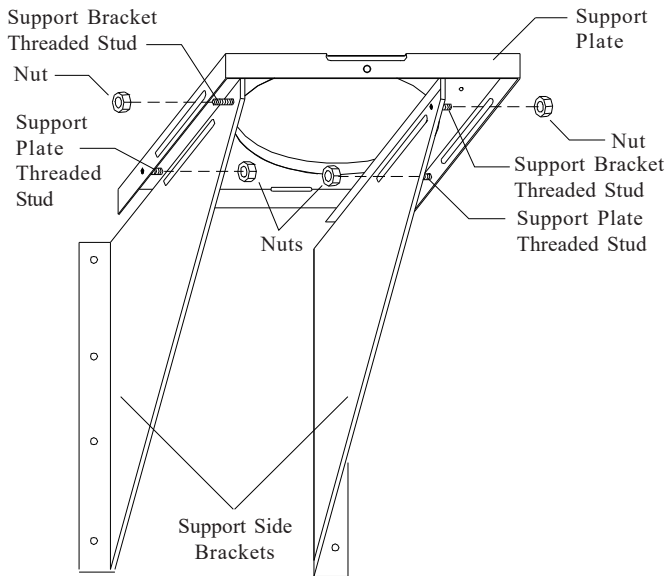
The maximum chimney height above an Adjustable Wall Support is indicated in Table 5 and illustrated in Figure 16, all of which must be above the support.

The following steps will assist you in the installation of the Adjustable Wall Support. Figure 16 shows a typical Wall Support installation through a combustible wall.

1. Determine the centre line of the horizontal connection (Chimney Length through the wall) and frame an opening to the dimensions specified for the Wall Thimble in a combustible wall (see Table 4 Section A and Figure 15).
2. For a non-combustible wall (concrete block or poured foundation), cut a hole 5mm (3/16") greater in diameter than the outside diameter of the chimney.
3. After framing in your opening to the dimensions specified in the Framing Dimensions in Table 1, install the outer half (with the unfinished square plate) of the Insulated Wall Thimble in the outside wall opening. Secure in place using appropriate fasteners through the pre-punched holes.
4. Install the inner half (with black plate) of the Insulated wall Thimble in the inside wall opening, ensuring that the shield slides into the shield of the outer half. Once in place and flush against the wall, fasten with appropriate fasteners through the pre-punched holes.
5. Assemble the side Brackets (point of triangle facing down) to the Support Plate (flange up) by inserting the threaded studs into the oblong slots. Install the supplied nuts on the threaded studs. (see Figures 17 & 18).

Distance from Wall to Chimney	Table 5 - Wall Support Chimney Height Chart			
	5" ID Chimney	6" ID Chimney	7" ID Chimney	8" ID Chimney
D (inches) Wall/Chimney	H(feet) Max. Height	H (feet) Max. Height	H (feet) Max. Height	H (feet) Max. Height
2	74	63	56	49
2.5	73	62	55	48
3	71	60	53	47
3.5	69	59	51	46
4	66	56	49	44
4.5	62	53	46	42
5	58	50	43	39
5.5	52	45	38	35
6	45	39	34	30

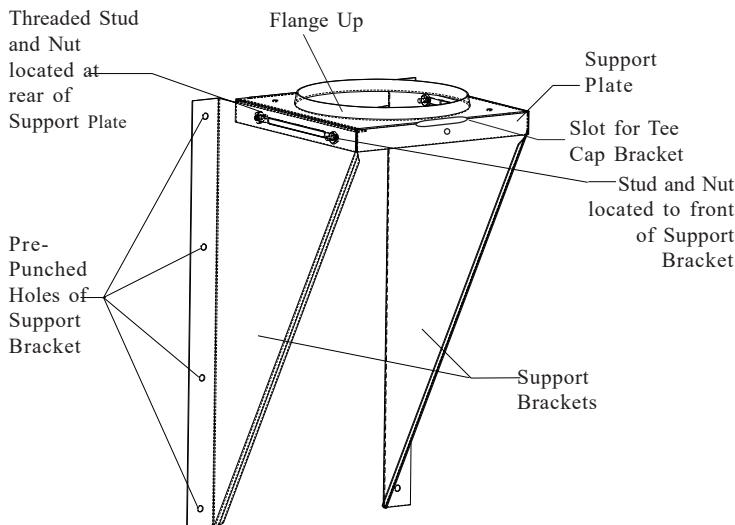
6. Ensure that the Wall Support is level, and secure to the wall through the pre-punched holes located on the sides of each of the wall support brackets using (8) #14 x 1-1/2" hex head lag screws or #10 x 1-1/2" wood screws. You can drill 5/32" pilot holes for the lag screws.



**FIG. 17 - UNDERSIDE VIEW OF THREADED STUDS AND NUTS**

7. Once in its final position and all clearances have been met, tighten each of the nuts on the threaded studs.

8. Attach the two (2) retainer clips to the bottom of the support plate and fasten with the supplied nuts and bolts using the two (2) holes on top of the support plate (see Figure 20).



**FIG. 18 - FRONT VIEW OF WALL SUPPORT ASSEMBLY**

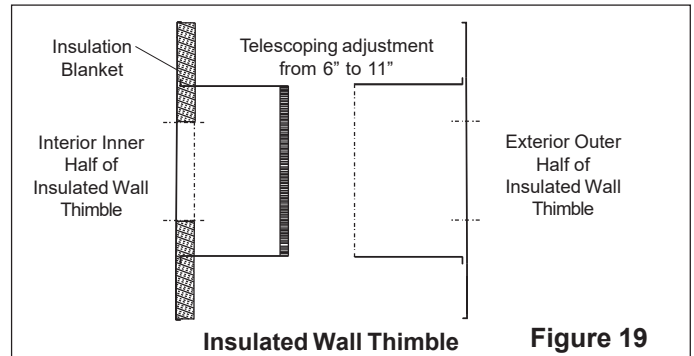
9. Place the insulated Tee on the support plate ensuring that the male coupler of the Tee is facing up and the flange on the top of the plate slides into the female coupler. Insert and secure the Tee Cap with the attached retainer clips (see Figure 20). In earthquake zones, secure the Tee to the flange on the support plate by installing 2 stainless steel sheet metal screws as per figure 20.

10. For extension of the Tee, slide an appropriate insulated Chimney Length through the Wall Thimble and attach it to the horizontal branch of the Insulated Tee with the supplied locking band. Make sure the nut and bolt are facing down to prevent any water from collecting in the locking band. The insulated length must protrude at least 76mm (3") through the wall into the room as per Figure 14a.

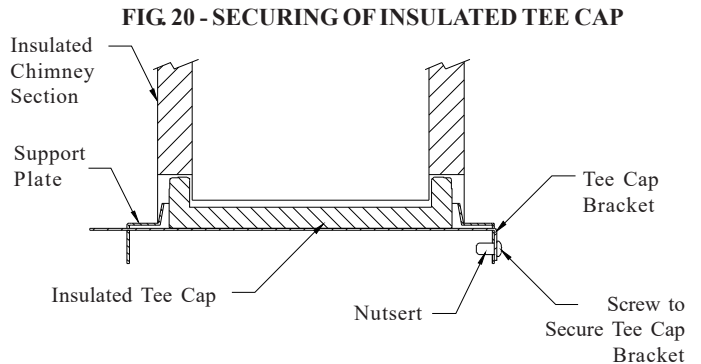
11. Use a non-hardening high-temperature sealant (500° F) to seal around the horizontal length where it enters the wall thimble or the concrete wall.

12. Chimney lengths above the Insulated Tee are simply stacked on and locked with a 1/8 clockwise turn. Locking bands must be used on all joints.

13. For lateral stability of the chimney above the support, a Wall Band must be used every 8 feet, and at least one Wall Band must be installed. Interior chimneys must use the Firestop Joist Shield (JS) in place of Wall Bands if extending through floor / ceiling penetrations.

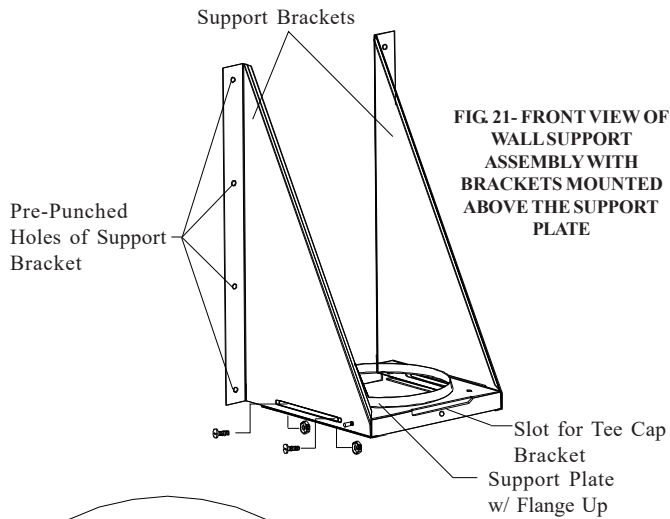


**Figure 19**

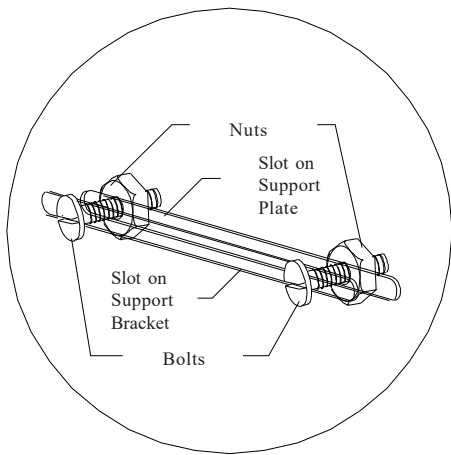


**WARNING:** The Insulated Tee Cap must be installed and secured in place. Failure to install retaining clips could cause fire, injury or death.

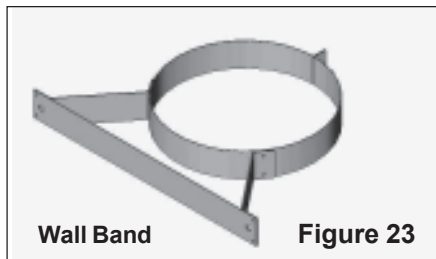
**NOTE:** Inverting the brackets (brackets mounted above the support plate) can be accomplished by inserting extra bolts through the oblong slots of the support side brackets and the support plate as per Figures 21 and 22. Secure with nuts. In this position, the range of adjustability is limited to 5" from the wall.



**FIG. 21- FRONT VIEW OF WALL SUPPORT ASSEMBLY WITH BRACKETS MOUNTED ABOVE THE SUPPORT PLATE**



**FIG. 22- SLOT AREAS WITH BOLTS AND NUTS ASSEMBLY OF SUPPORT BRACKET AND SUPPORT PLATE**



**Wall Band**

**Figure 23**

**WALL BAND**

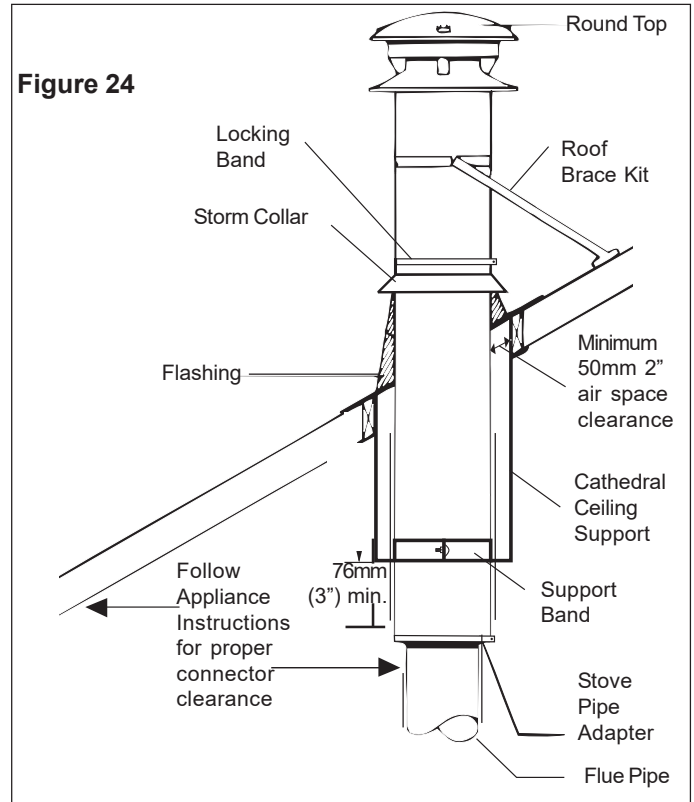
The Wall Band is used along an outside wall at 8 ft intervals for lateral stability. Secure the Wall Band bracket to the wall using two 6d or 2" spiral nails. For concrete walls use suitable masonry fasteners. The nut and bolt supplied will fasten the band around the chimney.

**CATHEDRAL CEILING SUPPORT**

A Cathedral Ceiling Support is available for 5" and 6" diameters chimney only. For other diameters, a roof support can be used to suspend the chimney below the roof. To complete a proper Cathedral Ceiling Support installation, the following parts may be required:

- Cathedral Ceiling Support /w 4 painted ceiling trim angles
- Roof Flashing w/ Storm Collar
- Suitable lengths of chimney
- Stove Pipe Adapter
- Trim Collar
- Round Top

The following instructions will assist you in the installation of your chimney with a Cathedral Ceiling Support. This support will hold up to 30' of chimney, of which 15' can be suspended below the box. Chimney joints made below the support must be secured with locking bands.



**Figure 24**

**NOTE:** The male coupler of the chimney length must be pointing upwards as per the arrow on the chimney label.

- The bottom chimney length should protrude into the living space so that proper clearances are maintained at the adapter (see Figure 24).
- The Cathedral Ceiling Support Box is manufactured to an overall outer dimension of 12" x 12" (305mm x 305mm). Therefore, the suggested framing to fit the box is 12-1/4" x 12-1/4" (311 x 311mm).
- After framing in your opening to the dimensions specified above and in Table 1, slide the Cathedral Support Box into the joist/rafter opening. Once the box is at the desired location, ensure the box is level and plumb. Nail the box to the framing using four 2" spiral nails or equivalent per side. The excess material sticking above the roof can either be trimmed off before attaching the box to the framing or, after it is installed the corners can be cut and the excess material folded down onto the roof deck.
- Install the Support Band on a chimney length at the desired position by tightening the support band with the bolt and nut. Secure the band to the chimney outer casing by screwing four stainless steel sheet metal screws through the support band and into the outer casing.
- Lower the chimney length down through the opening in the bottom of the support box, so that the Support Band makes contact with the bottom of the Support Box (see Figure 24).

Install additional chimney sections and lock together by turning clockwise until the two sections lock together tightly. Locking bands must be used at all joints. Continue in this manner until the required height above the roof is achieved.

Chimney sections installed below the Cathedral Support are locked together from below by turning counter-clockwise until tightly locked together with each joint being secured by locking bands which are provided. Do not offset the chimney below the Cathedral Support.

### ROOF SUPPORT

The following instructions will assist you in the installation of your chimney with a Roof Support. This support will hold up to 9.0 m (30') of chimney of which 6.0 m (20') may be suspended beneath it.

1. Frame a rectangular roof opening to provide a 50mm (2") minimum clearance from combustible materials (See Figure (25)).
2. Bend both chimney plates at the vertical slots to fit the outside curvature of the chimney length (Figure 25).

7. Attach the Roof Brackets to the chimney plates. Centre the assembly in the roof opening, ensuring that a 2" clearance to combustibles is maintained.

8. Adjust Roof Brackets to the roof pitch and tighten nuts. Attach to the roof with six (6) large wood screws per bracket with the inner-most screws going into the rafters or headers (See Figure 25 & 26).

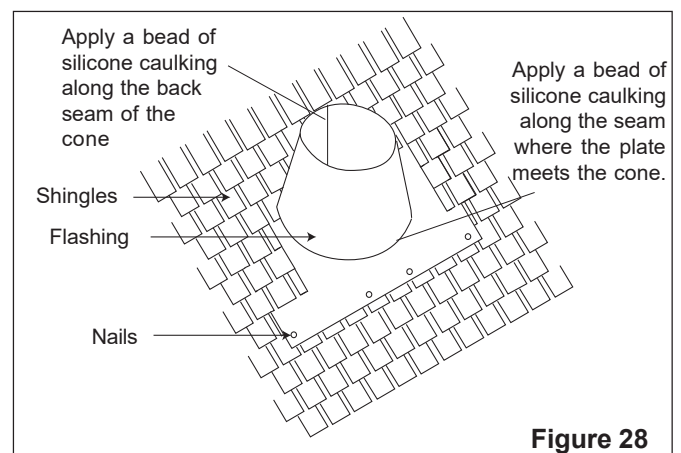
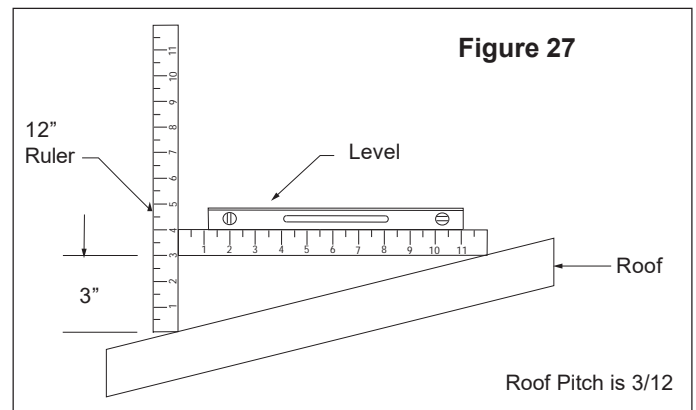
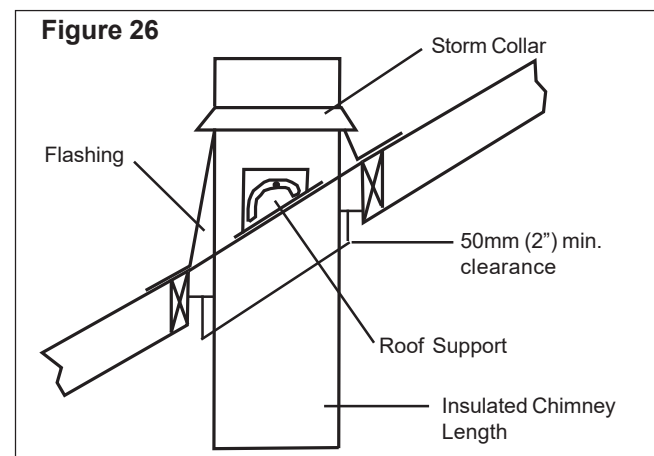
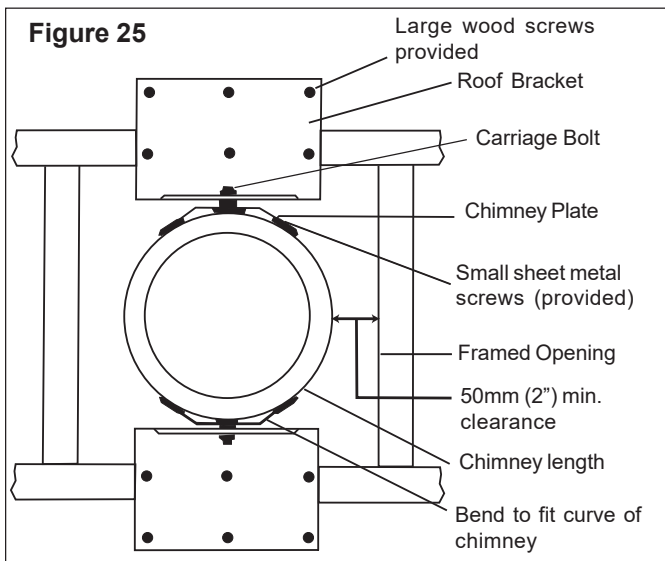
9. Additional chimney lengths above the support are simply stacked on and locked with a 1/8 clockwise turn.

10. Locking Bands must be used on all exterior joints.

11. Finish the chimney to its required height. If the chimney extends 1.5 m (5') or more above the roof, a Universal Roof Brace Kit is required (see Figure 36).

### ROOF FLASHING:

Ensure that you have the proper roof flashing by checking your roof pitch using a level and two rulers (see Figure 27) or by using a roof pitch card.



3. Determine the chimney plate position on the chimney casing (See Figure 26).

4. Install two (2) carriage bolts per chimney plate in the square holes.

5. Using the bent chimney plate as a template, drill 3/32" holes in the outer casing of the chimney (do not penetrate more than 12 mm (1/2") into the chimney). Attach the plate with the small sheet metal screws provided.

6. Install the second plate in a similar manner on the opposite side of the chimney length.

Once you have marked and located the area where the chimney will come through the roof, center, position and prepare the roof area by removing shingles, shingle nails and cutting the roofing material. Frame a RECTANGULAR opening to suit the pitch of the roof and ensure that a 2" (50mm) clearance is maintained to combustibles on all four (4) sides. This is done before extending the chimney above the roof. Do not nail the flashing to the roof at this time as adjustments may be required.

Slide the top edge (nearest the roof peak) of the flashing under the roofing shingles. At least half of the flashing (top and sides) should be UNDER the shingles and the lower end OVER the shingles to provide a watershed. Trimming off the shingles may be necessary around the cone of the flashing for a better fit. On existing roof application, lower a chimney length into the flashing opening and twist lock in place and secure with a Locking Band. Ensure that the chimney is level and plumb before nailing the flashing to the roof.

Nail the flashing to the roof deck (also under the shingles) along the upper edge and down each sides with 12 nails with neoprene washers or cover the heads with a suitable non hardening waterproof caulking. Seal the shingles to the plate in the same manner. As a precaution, apply a bead of caulking along all seams of the flashing as per Figure 28.

Apply a non-hardening high temperature silicone caulking just above the top of the flashing cone where it meets the chimney casing. Slide the Storm Collar through the applied caulking and place into its final position to ensure a waterproof joint. Apply additional caulking above the Storm Collar as required.

The Chimney, Flashing and Storm Collar may be painted with a heat resistant rust proofing paint when enclosing of the chimney is not possible or if exposed to wind driven ocean spray. Salty humid air causes metal to corrode faster than air with normal humidity. This will extend its life and improve the appearance and could be matched with the roof shingles. To improve adhesion to the chimney, degrease, clean and prime before painting. Follow the paint manufacturer's instructions.

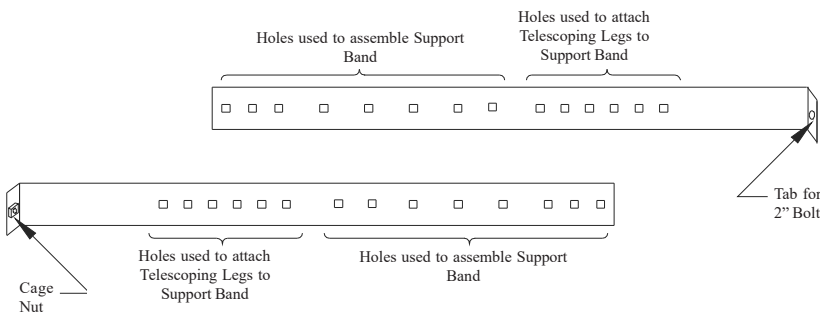
Continue adding chimney lengths until the proper height is achieved (see Figure 1 and Chart 2). Install a Round Top. The Round Top prevents entry of moisture which might lead to premature deterioration of the chimney.

**A Rubber Boot Flashing Kit** is available as an option for passing through a corrugated or metal roof. See separate instructions packaged with the Rubber Boot Flashing Kit. On metal or steep roofs, it is recommended that an ice deflector or "cricket" fabricated from heavy-gauge galvanized steel be installed. The wedge-shaped deflector is installed 2" from the chimney on the upper slope. Its function is to split ice and snow as they slide down the roof, preventing damage to the chimney.

**HEAVY DUTY UNIVERSAL ROOF BRACE KIT**

The HDURBK will provide lateral support to the chimney above the roof line. The HDURBK is required when the chimney extends 5 feet (1600mm) or more above the roof penetration. The kit contains Telescoping Legs, Support Band, Roof Angle Brackets and hardware package.

**Figure 29** Support Band Holes Identifier

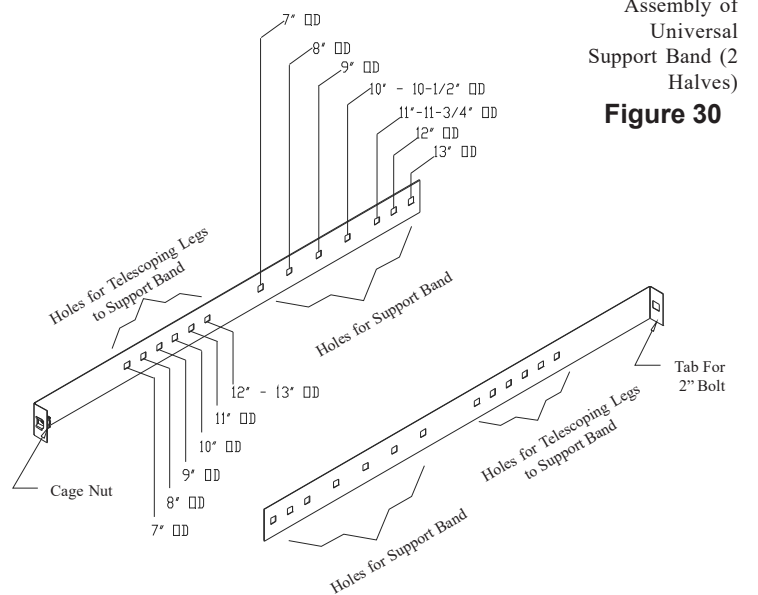


The HDURBK accommodates most models of chimneys with outer diameters ranging from 7" through 13". For larger diameter a suitable Bracing System would need to be constructed (guy wires).

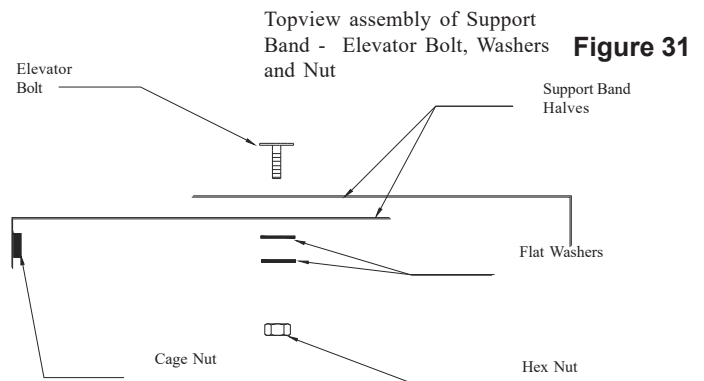
**NOTE:** Different holes combination can be selected as required.

**To Install:**

- A. Measure the **outside (OD)** diameter of your chimney.
- B. From the row of holes (see Figures 29 and 30), select the hole in each half that corresponds to the outside diameter identified with the chimney being installed. Place the two halves together. Insert an elevator bolt through the chosen holes (Ex - for a 10" OD chimney, place the elevator bolt through the holes identified for 10" OD). The elevator bolt should be oriented as shown in Figure 31. Secure the center bolt with washers and 1/4" flanged nut (see Figure 31). **NOTE:** On smaller diameter chimneys the excess band material can be cut off.

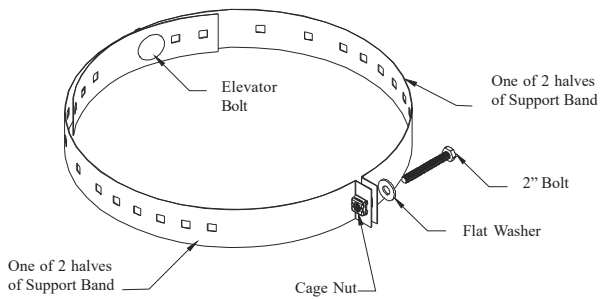


Assembly of Universal Support Band (2 Halves) **Figure 30**

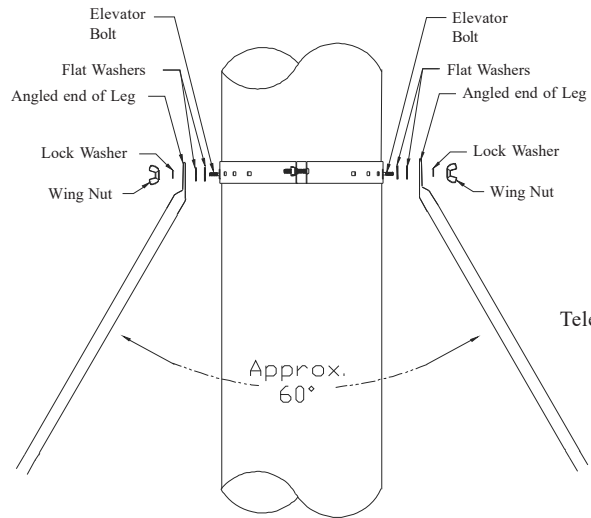


Topview assembly of Support Band - Elevator Bolt, Washers and Nut **Figure 31**

- C. Form the band into a circle (see Figure 32) and loosely connect tabs using the supplied 2" bolt into the cage nut located on one of the two formed tabs.
- D. Select the hole in each half that corresponds to the OD of the chimney. Insert an elevator bolt in each of the holes (1 per side).



Universal Support Band formed into a circle  
**Figure 32**



Assembly of Telescoping Legs to Support Band  
**Figure 34**

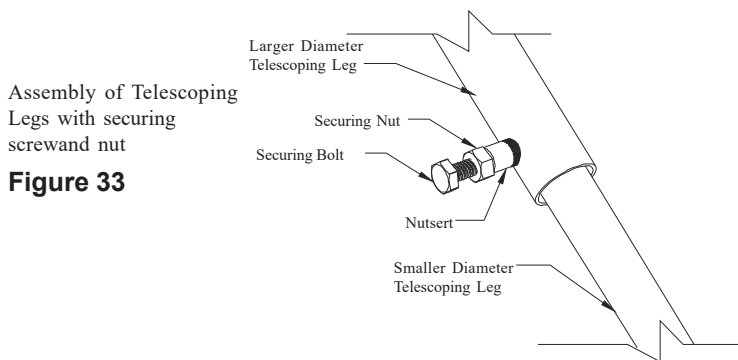
E. Position the Support Band approximately two thirds of the way up the chimney height (see Figure 36). The preferred location is next to a joint, immediately above or below a Locking Band. Secure Support Band by tightening the 2" bolt. **NOTE:** Only one chimney joint should be above a Roof Brace Kit. An additional Roof Brace Kit may be required for taller systems.

**Preparation of Telescoping Legs:**

F. Assemble the telescoping tubes by inserting the smaller diameter into larger one. Thread the securing nut to the securing bolt then thread this assembly into nutsert. Tighten firmly against the smaller tube which will lock them together (see Figure 33). Repeat for the other telescoping leg assembly.

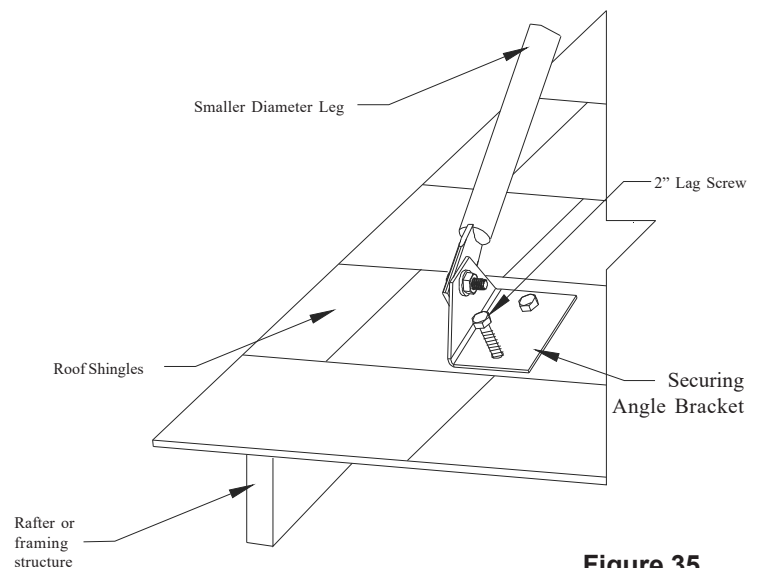
G. Place a flat washer on the elevator bolts and attach the top portion of each of the telescoping legs to the 2 elevator bolts on the Support Band with washers and nut (see Figure 34). Leg can be bent at an angle using the claw of a hammer.

H. Attach the other end of each telescoping leg assembly to an Angle Bracket using one (1) 1/4-20 X 1" bolt and nut (see Figure 35).



Assembly of Telescoping Legs with securing screw and nut  
**Figure 33**

J. Make sure the chimney is level and plumb. Check all required dimensions and angles, adjust if necessary. For added security, we recommend that you secure the inside and outside tubes together using # 8" x 1/2" stainless steel self tapping screw to permanently lock them in place.

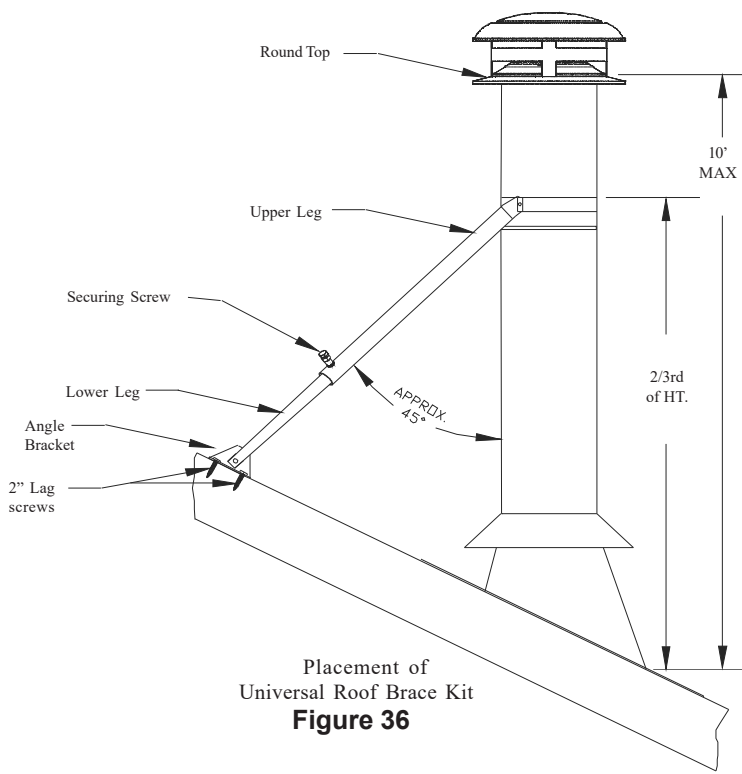


**Figure 35**

I. Determine the location of the two Angle Brackets on the roof structure. Ensure the fasteners are into rafters or framing and not just roof sheathing. Secure the Angle Brackets to the roof structure using two (2) 1/4 X 2" lag screws per brackets (see Figure 35). Apply a thin layer of caulking under the angle bracket (before securing in place) as well as over the lag screw heads.

K. The two telescoping legs should form an angle of about 60° to give support to the chimney in all directions. The angle of the telescoping legs should be approximately 45° from vertical when fastened to the roof (see Figures 34 & 36).

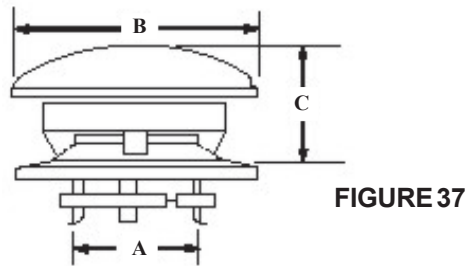
**NOTE:** Do periodic inspections of all fasteners including the securing screws as high winds can cause the chimney system above the roof to vibrate and in time loosen some of the fasteners.



Placement of  
Universal Roof Brace Kit  
**Figure 36**

**TYPE HT ROUND TOP - 5" to 8" only (10" have a different design)**

Attach the Type HT Round Top to the chimney by sliding it over the chimney length. ensure that the three (3) vertical tabs are located on the outside of the chimney length and that the Round Top sits flush on the top surface of the length. Wrap the band snug to the bottom of the 3 tabs and secure in place with the supplied nut and bolt.

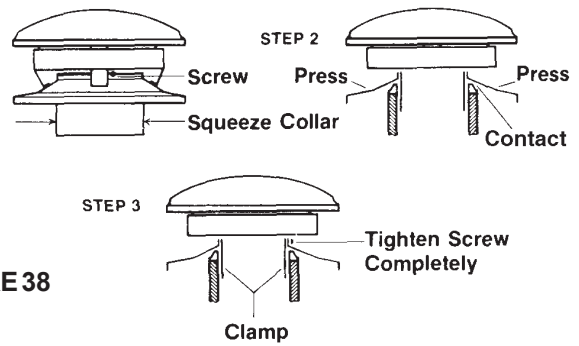


**FIGURE 37**

Chimney Dia.	A	B	C
5"	7"	10"	5"
6"	8"	12"	5-1/2"
7"	9"	14"	6-1/4"
8"	10"	16"	7"

Some Selkirk Tops (CT) have a nominal inch diameter expanding utility attachment adaptable to Selkirk Selkirk Chimney and other products of like internal diameter. To attach securely:

1. Loosen screw on top of collar and squeeze bottom to allow collar to enter pipe.
2. Press down evenly on lower skirt until it contacts upper end of pipe.
3. Tighten screw on collar to expand lower end and clamp to inside of pipe. Keep tightening screw until collar is expanded and fully tight.



**FIGURE 38**

**SPARKARRESTER (Part No. SA)**

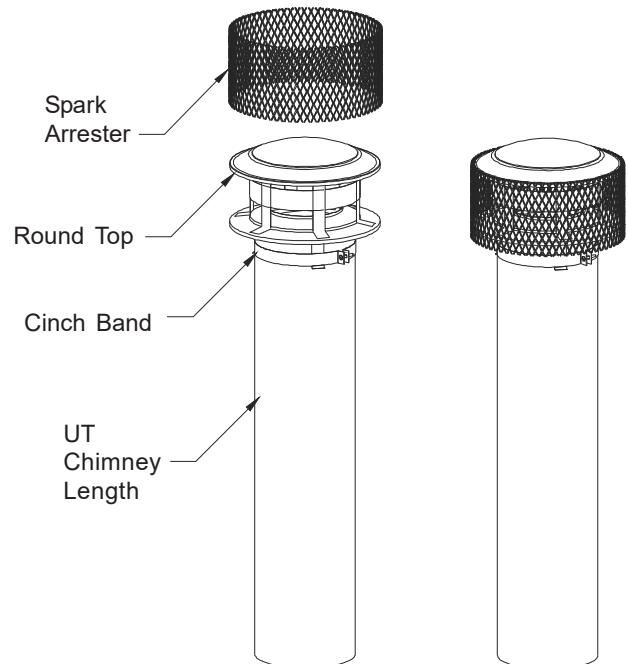
For 6" to 8" diameters a pre-formed Spark Arrester is available. See separate instructions packaged with the Spark Arrester.

**To Install:**

1. Place the pre-formed Spark Arrester directly over the dome and skirt of Round Top (Figure 2).
2. Ensure that the flanged end of the Spark Arrester is on top of dome and the bottom folded edge overlaps the skirt.

**If clogged:**

If the Spark Arrester becomes clogged with creosote, it should be cleaned or replaced. Remove Round Top by removing cinch band. Lightly tap away (from the outside of the Spark Arrester) any creosote residue. If necessary use a soft bristle brush for assistance. If Spark Arrester is to be removed from the Round Top, release the bottom edge of the Spark Arrester from the skirt edge and raise Spark Arrester from Round Top.



**FIGURE 39**

## **STOVE PIPE ADAPTER:**

Connect only to low heat (liquid fuel or gas fired) appliances with continuous flue gas temperatures below 540° C (1000° F). When installing a factory-built fireplace refer to the fireplace installation instructions for the proper chimney requirements.

To comply with the National Building Code of Canada the single wall base tee can be installed with a 229mm (9") minimum airspace clearance between connecting single wall material and combustible products provided that the flue gas temperature does not exceed 400° C (750° F) (most oil fired appliances). Otherwise, the minimum air space clearance must be 450mm (18"). Refer to the appliance installation instructions for the proper chimney requirements.

The connection of a single wall base tee or single wall flue pipe or double wall flue pipe to the insulated chimney must be secured with the screws supplied in the Support carton. The use of a stove pipe adapter is recommended with the first length, this will provide a positive connection between the insulated chimney and the appliance connector. The Stove Pipe Adapter is inserted into the female end of the first insulated chimney length and extends beyond the ceiling support approximately 32mm (1-1/4"). For a Cathedral Support and Wall Support application, the stove pipe adapter is inserted into the female end of the exposed chimney length and extend into the room and held in place with the finishing collar secured with 4 screws which is used to attach the stove pipe adapter to the finishing collar.

Install inter-connecting flue pipe following the appliance manufacturer's instructions, and appropriate building code requirements keeping in mind that the flue pipe run should be as short and straight as possible. All joints should be secured in place with three (3) sheet metal screws.

Besides following the appliance instructions for flue pipe, other rules that should be taken into account:

1. Never enclose single wall flue pipe, even at 18 inches clearance.
2. Never run it through ceilings or floors, or windows.
3. Don't use single wall flue pipe outdoors.
4. Always secure all single wall flue pipe joints with a minimum of 3 screws.
5. Obtain proper attachment parts for the appliance end and for the entry to the chimney.
6. Locate or support the flue pipe to avoid contact of damage.
7. Caps or plugs for single wall tees should be secured against falling out and designed so they can't leak creosote or rain.

## **MODEL UT ANCHOR PLATE**

The Anchor Plate may be used for adapting the UT chimney to a "Listed" Factory-Built Fireplace certified for use with Model UT.

NOTE: It is of the utmost importance that the Anchor Plate be installed in accordance with the manufacturers installation instructions supplied with the "listed" Factory-Built Fireplace.

## **CHIMNEY OPERATION AND MAINTENANCE:**

The need for chimney maintenance depends on the kind of appliance and how it is operated. Gas and oil-burning appliances need very little, but wood-burning appliances may need a great deal of chimney maintenance.

### **IMPORTANT**

Burning wood produces creosote, soot, and fly ash which tend to collect in chimney flue and on termination parts causing reduced flow of gases through the chimney. Check top weekly for excessive accumulation of these normal combustion products and clean as necessary. If the spark arrester becomes clogged with creosote, it should be cleaned or replaced.

With a new chimney installation, the chimney should be inspected at least once every 2 weeks during the heating season to determine if a creosote or soot buildup has occurred. When familiar with the appliance and chimney characteristics, the chimney should be inspected at least once every 2 months during the heating season.

If creosote or soot has accumulated, it should be removed to reduce the risk of a chimney fire. Depending on the rate of buildup, as you learn what is going on in the chimney, you can adjust your cleaning schedule.

If you have any doubts about your ability to clean the chimney, or if the deposits are very heavy and hard to remove, call a certified chimney sweep. Do not try to burn them off.

If chemical cleaner is used to assist in cleaning your chimney, make sure it is a product which is non corrosive to the chimney liner. The optimal method for cleaning a chimney is by a mechanical brushing of the chimney in conjunction with a complete evaluation of the system by a certified chimney sweep. The National Fire Code of Canada states: "Every chimney flue and flue pipe shall be inspected and cleaned annually or as often as maybe necessary, to keep the chimney and flue pipe free from dangerous accumulations of combustible deposits".

## **CHIMNEY FIRES AND WHAT TO DO ABOUT THEM:**

Your Selkirk chimney is not intended or designed for use as a combustion or fire chamber. If the fire in your appliance has gotten out of control, or if you suspect a chimney fire for any reason, follow these steps:

1. Immediately close all dampers and/or air entrance to your appliance.
2. Alert your family to the possible danger.
3. Inspect your appliance and chimney for possible fires, if in doubt, alert your Fire Department.
4. Do not use salt or water on the fire. Salt is corrosive and water will cause a dangerous steam explosion. You may be able to control the fire by using ashes, sand or baking soda, since baking soda is an ingredient used for dry chemical fire extinguishers.
5. Do not continue to use your appliance until it and your chimney have been thoroughly inspected by a certified service technician.
6. After a chimney fire, when it is safe to do so, check internal locations such as the attic and under the roof and keep watching for two or three hours. There may be delayed smoldering and subsequent ignition even if the fire inside the chimney has been controlled.

## **PAINTING OF THE EXTERIOR CHIMNEY**

If the chimney cannot be enclosed it is highly recommended to paint all exterior chimney, including the roof flashing and storm collar with a heat resistant rust proofing paint when the chimney is exposed outdoors to wind driven ocean spray. Salty humid air causes metal to corrode faster than air with normal humidity. This will extend its life and improve the appearance. To improve adhesion, degrease, clean, prime before painting. Follow the paint manufacturer's instructions.

## OFFSET CHART CHIMNEY INSTALLATION (5" to 8" only)

It may be necessary to offset the chimney in order to clear a joist or an obstacle. The three (3) charts below will assist you in selecting the proper combination of elbow angle and chimney length(s) that will provide the necessary degree of offset within an available height.

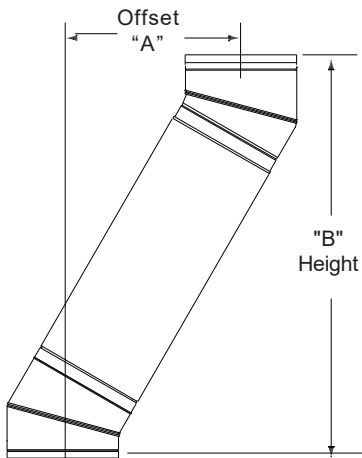
1. Select the column with the proper chimney diameter of your system.

2. Determine the distance of the offset required by dropping a plumb line for an accurate measurement. The offset is measured at the chimney centre line as per the "A" Offset measurement in the diagram below.

3. On the chart, find the predetermined distance (under the "A" column) required for the 15° elbow. For greater offset, use the 30° or 45° offset charts.

4. After finding the offset, look at the "B" (height) measurement in the chart to find the specified height. The appropriate "chimney lengths" required in between elbows is found in the left hand side column on the chart.

\* Substituted with 36" Length (5" only)



**NOTE:**

- UltraTemp chimney can be offsetted using 15°, 30° or 45° elbows. Combining offsets for a greater angle is not permitted.
- One pair of (two) 15°, 30° or 45° elbows may be used per interior installation.
- Never install an elbow in a joist area. Chimney sections must pass vertically through framed joist areas.
- Each elbow support will support 30 feet of chimney.
- An intermediate support must be used at 4 feet intervals in conjunction with an elbow support.
- The maximum length of chimney allowed between elbows is 16 feet.

All measurements in inches.  
Construction tolerances ± one inch.

15° OFFSET CHART								
Chimney Lengths	5" Diameter		6" Diameter		7" Diameter		8" Diameter	
	A	B	A	B	A	B	A	B
none	7/8	6-13/16	15/16	7-1/16	1	7-5/16	1	7-9/16
6"	2-1/16	11-1/8	2-1/8	11-3/8	2-1/8	11-11/16	2-3/16	11-15/16
9"	2-2/16	14	2-7/8	14-1/4	2-15/16	14-9/16	2-15/16	14-13/16
12"	3-9/16	17	3-5/8	17-1/4	3-11/16	17-7/16	3-11/16	17-11/16
18"	5-1/8	22-3/4	5-3/16	23	5-1/4	23-1/4	5-1/4	23-1/2
24"	6-11/16	28-1/2	6-3/4	28-3/4	6-13/16	29-1/16	6-13/16	29-5/16
36"	9.13/16	40-1/8	9-7/8	40-3/8	9-7/8	40-5/8	9-15/16	40-7/8
48"	n/a	n/a	13	52	13	52-1/4	13-1/16	52-1/2
*48" & 12"	12-1/2	50-1/4	15-11/16	62-1/8	15-3/4	62-3/8	15-3/4	62-5/8
*48" & 24"	15-5/8	61-7/8	18-13/16	73-11/16	18-3/16	73-15/16	18-7/8	74-3/16
*48" & 36"	18-3/4	73-7/16	21-7/8	85-5/16	21-1/16	85-9/16	21-15/16	85-13/16

30° OFFSET CHART								
Chimney Lengths	5" Diameter		6" Diameter		7" Diameter		8" Diameter	
	A	B	A	B	A	B	A	B
none	3-3/8	12-9/16	3-3/8	12-9/16	3-3/4	14-1/16	4	14-13/16
6"	4-9/16	16-7/8	4-9/16	16-7/8	4-15/16	18-7/16	5-1/8	19-3/16
9"	5-5/16	19-3/4	5-5/16	19-3/4	5-11/16	21-5/16	5-15/16	22-1/16
12"	6-1/16	22-3/4	6-1/16	22-3/4	6-7/16	24-3/16	6-11/16	24-15/16
18"	7-5/8	28-1/2	7-5/8	28-1/2	8	30	8-1/4	30-3/4
24"	9-3/16	34-1/4	9-3/16	34-1/4	9-9/16	35-13/16	9-13/16	36-9/16
36"	12-5/16	45-7/8	12-5/16	45-7/8	12-11/16	47-7/8	12-7/8	48-1/8
48"	n/a	n/a	15-7/16	57-1/2	15-13/16	59	16	59-3/4
*48" & 12"	25-7/8	51-9/16	31-7/8	61-15/16	32-1/4	63-7/16	32-1/2	64-3/16
*48" & 24"	31-7/8	61-15/16	37-7/8	72-5/16	38-1/4	73-13/16	38-7/16	74-9/16
*48" & 36"	37-7/8	72-5/16	43-7/8	82-11/16	44-1/4	84-3/16	44-7/16	84-15/16

45° OFFSET CHART								
Chimney Lengths	5" Diameter		6" Diameter		7" Diameter		8" Diameter	
	A	B	A	B	A	B	A	B
none	n/a	n/a	5-3/8	12-15/16	5-11/16	13-3/4	5-9/16	13-3/8
6"	n/a	n/a	8-9/16	16-1/8	8-7/8	16-15/16	8-3/4	6-9/16
9"	n/a	n/a	10-5/8	18-1/4	11	19-1/16	10-7/8	18-11/16
12"	n/a	n/a	12-3/4	20-3/8	13-1/8	21-3/16	13	20-13/16
18"	n/a	n/a	17	24-5/8	17-3/8	25-7/16	17-1/4	25-1/16
24"	n/a	n/a	21-1/4	28-7/8	21-5/8	29-11/16	21-1/2	29-5/16
36"	n/a	n/a	29-3/4	37-5/16	30-1/16	38-18	29-15/16	37-3/4
48"	n/a	n/a	38-1/4	45-13/16	38-9/16	46-8/8	38-7/16	46-1/4
48" & 12"	n/a	n/a	45-11/16	53-1/4	46	54-1/16	45-7/8	53-11/16
48" & 24"	n/a	n/a	54-3/16	61-3/4	54-1/2	62-9/16	54-3/8	62-3/16
48" & 36"	n/a	n/a	62-5/8	70-3/16	62-15/16	71	62-13/16	70-5/8

## CHART 2 - CHIMNEY HEIGHT ABOVE THE ROOF

Requirement # 1 : The code requires that the chimney must extend at least 3 feet (900mm) above the highest point of the roof that it penetrates.  
 Requirement # 2 : It must also be 2 feet (609mm) above any roof, wall or other obstruction within a horizontal distance of 10 feet (3m).

The following Chart is to assist you in determining the minimum chimney height you will require above the roof. You may need to add to this height as nearby buildings, trees and other parts of the house roof could interfere with airflow over and around the top of the chimney and affect its performance. If you think a nearby obstacle could affect draft, you might want to install one or more additional lengths.

DISTANCE FROM PEAK	PITCH OF ROOF											
	1/12	2/12	3/12	4/12	5/12	6/12	7/12	8/12	9/12	10/12	11/12	12/12
	<b>CHIMNEY HEIGHT ABOVE ROOF (INCHES)</b>											
10 Ft	*36	44	54	64	74	84	94	104	114	124	134	144
9 Ft	*36	42	51	60	69	78	87	96	105	114	123	132
8 Ft	*36	40	48	56	64	72	80	88	96	104	112	120
7 Ft	*36	38	45	52	59	66	73	80	87	94	101	108
6 Ft	*36	36	42	48	54	60	66	72	78	84	90	96
5 Ft	*36	*36	39	44	49	54	59	64	69	74	79	84
4 Ft	*36	*36	36	40	44	48	52	56	60	64	68	72
3 Ft	*36	*36	*36	36	39	42	45	48	51	54	57	60
2 Ft	*36	*36	*36	*36	*36	36	38	40	42	44	46	48
1 Ft	*36	*36	*36	*36	*36	*36	*36	*36	*36	*36	*36	36

All measurements are in inches with the exception of "distance from the peak" being in feet.

**\* Defaulted to 36" to meet requirement #1. Both requirements (#1 and #2) must be met.**

- If the chimney extends more than 5 feet or more above the roof, a Universal Roof Brace Kit is required.
- All lengths above the roof must have locking bands at all joints. This will eliminate the risk of sections becoming undone below the roof line when the Round Top is removed when inspections and cleaning of the system is being done.

## REPLACEMENT PARTS LIST

DESCRIPTION	ULTRATEMP PARTNO. 5" - 8" / 10"	DESCRIPTION	ULTRATEMP PARTNO. 5" - 8" / 10"
36" Chimney Length	*UT-36 / *U-36	Insulated Wall Thimble	*T-IWT / *S-IWT
24" Chimney Length	*UT-24 / *U-24	Wall Band	*T-WB / *S-WB
18" Chimney Length	*UT-18 / *U-18	Universal Roof Brace Kit	URBK / N/A
12" Chimney Length	*UT-12 / *U-12	Anchor Plate	*T-AP / *S-AP
6" Chimney Length	*UT-06 / *U-6	Adjustable Attic Insulation Shield	*TAAIS // *S-AIS
Tee with Insulated Plug	*T-ITP / *S-IT	Firestop Joist Shield	*T-JS / *S-JS
15° Elbow Kit	*T-EL15KIT / *U-EL15 Kit	Firestop Spacer	*T-FS / *S-FS
30° Elbow Kit	*TEL30KIT / *U-EL30 Kit	Type HT Round Top	*T-RT / *S-CT
Ceiling Support	*T-CSB / N/A	Flat Roof Flashing	*T-FF / *S-TF
Adjustable Wall Support	*T-AWS / *S-AWS	1/12 - 7/12 Roof Flashing	*T-FA / *S-AF6
Cathedral Ceiling Support Kit	*T-CCSK / N/A	8/12 - 12/12 Roof Flashing	*T-FAA / *S-AF12
Roof Support	URSP / *S-RSP	Storm Collar	*T-SC / *S-SC
Locking Band	*T-LB / *S-LB		
Stove Pipe Adapter	*T-AD / *S-CPA		

\* Specifies chimney diameters (5" to 10").

## **“SMART CHOICE” LIMITED LIFETIME WARRANTY**

Selkirk Corporation, (“Selkirk”, “we”, “us”, “our”) warrants our residential Chimney & Venting products (\* defined below) to be free from defects in material and workmanship. For products installed after January 1, 2009, for a period of Ten (10) years from original installation, we will provide replacement product with a similar or like quality of available Selkirk product, free of charge, excluding any installation costs. From the Eleventh (11) through Fifteenth (15) years, we will provide replacement product at a cost of 75% off the published Retail Price in effect on the date the claim is received, excluding any installation costs. At expiration of the Fifteen (15) year term, we will provide replacement product at a cost of 50% off the published Retail Price in effect on the date the claim is received excluding any installation costs. This warranty coverage is non-transferable and applies exclusively to the original consumer.

### **PROFESSIONAL INSTALLATION:**

If installation is performed by Professional Installers certified in Canada by WETT or APC or in the USA by NFI or CSIA, we will provide replacement product with a similar or like quality of available product, free of charge (excluding any installation costs) for the full Fifteen (15) years from the date of original installation. To be eligible for this additional warranty the consumer must provide a proof of installation by a Professional Installer when submitting a claim.

### **LIMITATIONS:**

BUYER'S REMEDIES ARE LIMITED TO REPAIR OR REPLACEMENT OF THE PRODUCT AND DO NOT INCLUDE INSTALLATION COSTS. EXCEPT AS SET FORTH HEREIN, ALL OTHER WARRANTIES (EXPRESS OR IMPLIED, INCLUDING THE WARRANTIES OF MERCHANTABILITY AND FITNESS FOR A PARTICULAR PURPOSE) ARE HEREBY DISCLAIMED. IT IS AGREED THAT THIS SHALL BE THE SOLE AND EXCLUSIVE REMEDY OF THE BUYER. IN NO EVENT SHALL WE BE LIABLE FOR ANY CONSEQUENTIAL, SPECIAL OR PUNITIVE DAMAGES ARISING DIRECTLY OR INDIRECTLY FROM THE USE OF THE PRODUCTS WHETHER BASED ON WARRANTY, CONTRACT NEGLIGENCE OR STRICT LIABILITY.

ALL LENGTHS, TEES, ELBOWS, AND COMPONENTS SUPPLIED BY US ARE SUBJECT TO WARRANTY COVERAGE. PRODUCT SUPPLIED BY US AS REPLACEMENT FOR ORIGINAL MATERIAL WILL BE SUBJECT TO A ONE-YEAR WARRANTY COVERAGE WITH THE EXCEPTION OF SAF-T PIPE WHICH IS SUBJECTED TO A 5 YEAR LIMITED WARRANTY COVERAGE FROM DEFECTS IN MATERIAL OR WORKMANSHIP WHEN PROPERLY INSTALLED PURSUANT TO THE MANUFACTURER'S INSTALLATION INSTRUCTIONS AND APPROPRIATE CODES.

**WARNING:** FAILURE TO INSTALL OR OPERATE PRODUCTS ACCORDING TO THE MANUFACTURER'S INSTRUCTIONS, OR FAILURE TO USE PRODUCTS WITH RESIDENTIAL APPLIANCES THAT HAVE BEEN CERTIFIED AT AN ACCREDITED LABORATORY WILL VOID ALL APPLICABLE WARRANTIES.

### **THIS WARRANTY DOES NOT COVER:**

- (a) any non-stainless base tee unit mounted or connected to an Insulated Chimney system;
- (b) costs (labor or otherwise \*\*) associated with either removing a previously installed product, installing a replacement product, transportation or return of a product, or transportation of replacement product;
- (c) damage to the finish of products caused by the use of improper solvents/chemicals or improper (or lack of) cleaning methods;
- (d) damage resulting from normal wear and tear, corrosion from salt air or failure to reasonably clean, care for or maintain products in accordance with our installation instructions/recommendations;
- (e) damage (to products, appliances or structure) based on or resulting from improper installation or repair, misuse or abuse (including, but not limited to, excessive or improper operating condition), or alteration or adjustment other than in conformity with our installation instructions and specifications, whether performed by a contractor, service company, technician, or yourself;
- (f) any products that have been moved from their original installation site;
- (g) damage caused by burning driftwood, garbage, or any other prohibitive material that has been burned in the appliance served by the chimney;
- (h) damage that results from accidents such as riot, fire, flood, high winds, “acts of God”, or any other contingency beyond our control.

\*\* Due to the wide variance in installation practices and other conditions beyond our control, except as stated above, we do not guaranty or in any way warrant the installation of Chimney and Venting products.

**CLAIM PROCEDURE:** If you believe that a product is defective, notify us in writing at:

**SELKIRK CANADA INC**  
P.O. Box 526, Depot 1,  
Hamilton, Ontario, CANADA, L8L 7X6  
ATTN: WARRANTY CLAIMS  
1.888.735.5475  
www.selkirkcorp.ca

**SELKIRK CORPORATION**  
4460 44th Street S.E., Suite F  
Grand Rapids, MI 49512  
ATTN: WARRANTY CLAIMS  
1.800.433.6341  
www.selkirkcorp.com

Notification should include a description of the product, model and serial number (if applicable) and a description of the product defect. Upon receipt of a written claim under this limited warranty and evidence of the date of purchase or installation, at our option and in our sole discretion, we will provide replacement product with similar or like quality of available product excluding any installation costs. We reserve the right to inspect or investigate any warranty claims prior to determining whether to provide replacement product. If, as determined by us, that repair or replacement of the product is not commercially practicable or cannot be completed in a timely manner, we may refund the prorated purchase price paid for the product upon verification by providing a copy of your invoice or receipt of bill of sale.

\*Selkirk products covered under this warranty: AFCL, ALT, BV (SD, MD, LD), CF, DCC, DFS, DSP, DT, DWC, DWS/SWC, E, EFC, FC (JSC), GT, GTL, HT, OV, PL, QC, R, RF, RV, SAF-T LINER, SAF-T PIPE, SC-1 (JM), SFCL, SPR, SPV, ST, SSFL, SSRL, U1, UPP, UPC, USP, UT, UTL, VP, WV.

510007 03/23

Leave with homeowner. Homeowner: Keep in a safe place for future reference.

**PRODUCT INFO**

CHIMNEY MODEL : **Ultra-Temp**

FLUE SIZE \_\_\_\_\_

TOTAL HEIGHT \_\_\_\_\_

INSIDE INSTALLATION  OUTSIDE INSTALLATION

CONNECTED TO (type of appliance):

- BOILER
- FURNACE
- LISTED FACTORY-BUILT FIREPLACE
- OTHER (specify) \_\_\_\_\_

LOCATION OF APPLIANCE:

- BASEMENT
- MAIN FLOOR
- OTHER (specify) \_\_\_\_\_

INSTALLATION DATE: \_\_\_\_\_

**DEALER INFO**

DEALER NAME: \_\_\_\_\_

Address: \_\_\_\_\_

City: \_\_\_\_\_

Province: \_\_\_\_\_

**TECHNICIAN INFO**

TECHNICIAN NAME: \_\_\_\_\_

Address: \_\_\_\_\_

City: \_\_\_\_\_

Province: \_\_\_\_\_