



S-5

Installation Instructions

Covering – Insulated Tee, Wall Support Kit, Insulated Elbow & Interior Resupport

Read Sheet GS for important clearance and safety precautions before installing any of the parts described by this Sheet. Sheet GS is packaged with Supports.

For longer installation life, all non-stainless steel exterior metal parts should be painted.

WALL SUPPORT KIT, INSULATED TEE FRAMING (PART NO. WSK WITH PART NO. IT)

The Selkirk Chimney System (SCS) Insulated Tee may be supported along an exterior or interior wall of any kind using the Wall Support Kit (WSK). The Wall Support will allow for an adjustment of 2" to 6" from a combustible vertical wall (see Fig. 1a & Fig. 3). Pem-studs are factory installed on both side brackets and the support plate for fast and easy assembly.

The maximum chimney height above the Wall Support whether supported along an interior or exterior wall is indicated in Table 2 and illustrated in Fig. 3.

NOTE: If installing a 10" or larger chimney the Wall Support is a non-adjustable version which comes with support braces and provides a 2" clearance when properly installed. Maximum support height is 50 Feet for 5" through 8" and 40 Feet for 10" (see Fig. 1b).

If supported along an interior wall in a non-attic area the chimney must be fully enclosed with a minimum of 2 inches air space clearance. In the attic area the chimney may be fully enclosed or an Attic Insulation Shield may be used. Full enclosure is preferable for better chimney operation. See the appropriate instructions for Fire Stops, Attic Insulation Shields (Instruction Sheet S-2) and the general instructions on installation (Instruction Sheet GS) for installing chimney above Tee.

If supported along an exterior or interior wall, Wall Bands (WB) must be installed every 8' to insure chimney stability and maintenance of 2 inches air space clearance. In any chimney installation, two points of stabilization are necessary hence at least one Wall Band must be installed. It is desirable to fully enclose an exterior chimney with minimum 2 inches air space clearance to reduce creosote buildup and to promote draft.

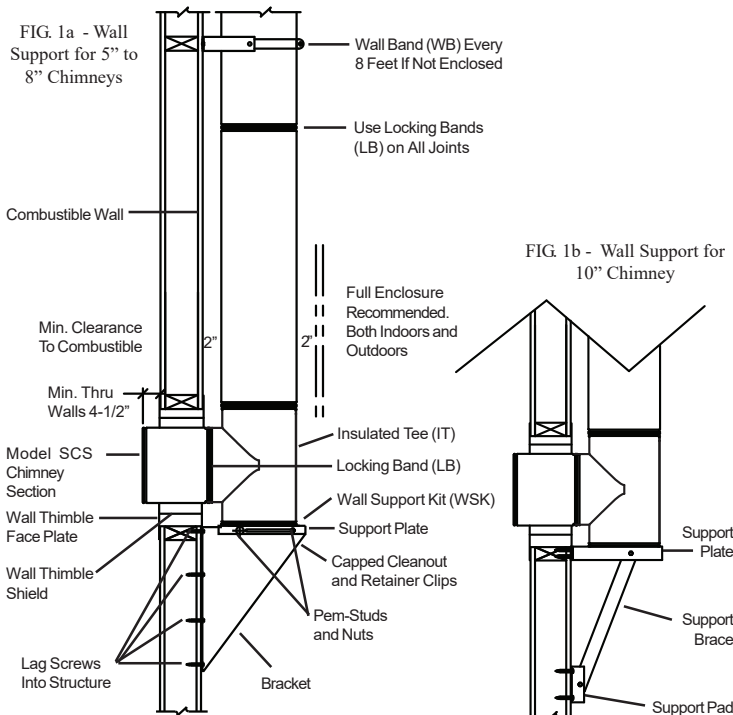

Locking Bands (LB) or 3 stainless steel sheet metal screws must be used on all joints between chimney sections (See Sheet GS).

WARNING

Failure to follow the installation instructions could cause **FIRE, CARBON MONOXIDE POISONING, OR DEATH**. If you are unsure of installation requirements, call the Phone Number listed on the instructions or visit www.selkirkcorp.com.

IMPORTANT

Chimney Sizes 5", 6", 7" and 8" are Type HT.

To penetrate a wall, one section of the SCS chimney may be attached to the snout as illustrated in Fig. 1a. The end of the added section must extend a minimum of 4-1/2 inches beyond the face of the wall. A Fire Stop/Trim Collar (TCDS) fits over the added horizontal section, and if the tee section and vertical portion of chimney are not fully enclosed, a wall spacer or sheet metal flashing should be used as illustrated in Fig. 1. Two inches air space clearance must be maintained through the wall.

The framing dimensions for Wall Support are illustrated in Fig. 2 and given in Table 1.

WSK Size	DIM A	DIM B
5"	11"	9-1/4"
6"	12"	9-1/4"
7"	13"	10-1/4"
8"	14"	11-1/4"
10"	16"	13-1/4"

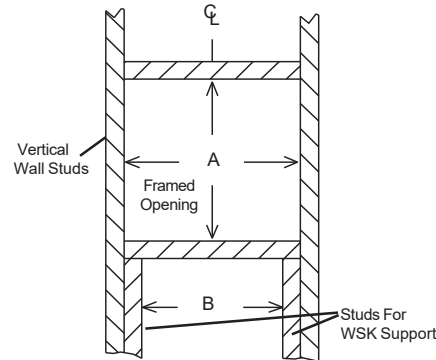

FIG. 2 - Framing for Wall Support Kit

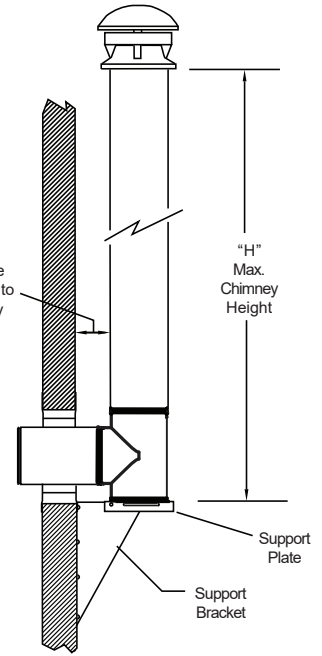

FIG. 3 - See Table 2 for Maximum Chimney Heights based upon Chimney Diameter and Distance from Wall

Distance from Wall to Chimney	Table 2 - Wall Support Chimney Height Chart			
	5" ID Chimney	6" ID Chimney	7" ID Chimney	8" ID Chimney
D (inches) Wall/Chimney	H (feet) Max. Height	H (feet) Max. Height	H (feet) Max. Height	H (feet) Max. Height
2	74	63	56	49
2.5	73	62	55	48
3	71	60	53	47
3.5	69	59	51	46
4	66	56	49	44
4.5	62	53	46	42
5	58	50	43	39
5.5	52	45	38	35
6	45	39	34	30

NOTE: This Table is applicable only for chimney diameters of 5" to 8".

Follow these simple steps for a wall supported chimney installation.

1. Assemble the side brackets (peak of triangle facing down*) to the support plate (flange up) by simply lining-up the pem-studs into the oblong slot openings as per Figure 4.

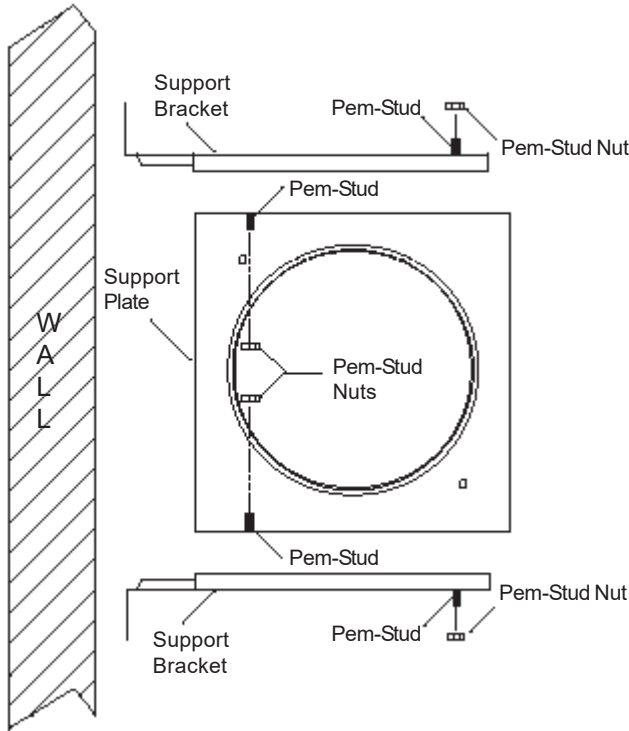

FIG. 4 - BOTTOM VIEW - PEM-STUDS LOCATION

2. Attach the two (2) retainer clips to the bottom of the plate and fasten with the supplied nut and bolts using the two (2) holes on top of the plate.
3. From outside the building, slide the Tee and the appropriate chimney length (ensure that the extension of chimney through a combustible wall extend 4-1/2" through the wall into the room) through the wall thimble or exterior firestop spacer ensuring the male coupler on the tee is facing up.
4. Place the assembled Wall Support against the wall (plate up) directly below the tee. Slide the Wall Support up to the tee ensuring that the flange of the plate slides into the female couple of the tee.
5. Level and secure the Wall Support brackets to the wall with the supplied lag screws (8) through the pre-punches holes of the side brackets. You can drill 5/32" pilot holes for the lag screws. Once in its final position and all clearances have been met, tighten each of the nuts on the pem-studs.

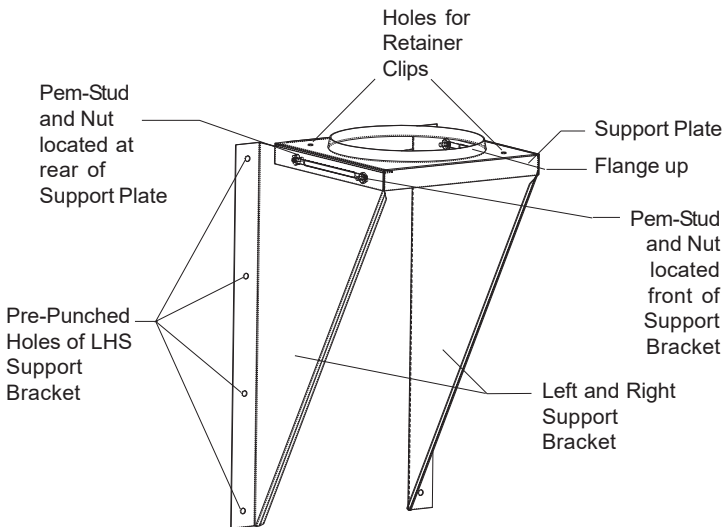

FIG. 5 - FRONT VIEW OF WALL SUPPORT ASSEMBLY

6. Install the tee cap into tee and secure with the two (2) retainer clips and wing nuts (see Figure 6).

7. For support of chimney above supports, a Wall Band (WB) should be used every 8 feet, and at least one Wall Band must be installed.

8. In earthquake zones, drill through the lower end of the tee and through the flange or coupler on the plate for at least two stainless steel sheet metal screws as shown in Fig. 6.

* Inverting the brackets (the peak of triangle pointing up) can be accomplished by inserting bolts and nuts (not supplied) through the oblong slots of the side brackets and the support plate. In this position, the range of adjustability is limited to 5" from the wall.

Fig. 6
SECURING TEE
CAP

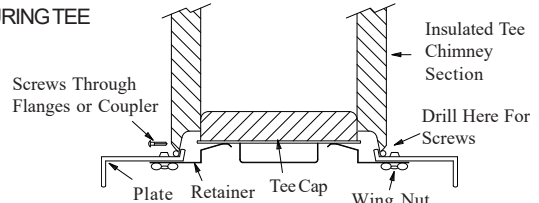

WARNING: Tee Cap and Retainers must be installed. Failure to install retaining clips could cause fire, injury or death.

15° & 30° INSULATED ELBOW (PART NO. EL, All Sizes; EL30, 6", 7" and 8" only)

The Selkirk Chimney System (SCS) 15-degree or 30-degree Elbow adapts the chimney for installations where the termination cannot be located directly above the initial vertical run of the chimney. The maximum offset is 30 degrees from vertical. The inclined length must be resupported at 4' spans (Max). Adjustment of 0-30 degrees is possible by using two 15 degree elbows.

Resupport chimney at first section above upper offset by using Interior Resupport (IR) or (UWRSA).

If the offset sections of chimney are in an interior occupied area, they must be fully enclosed with a minimum of 2 inches air space clearance. In non-occupied area the chimney may be fully enclosed or an Attic Insulation Shield may be used. See the appropriate instructions for Fire Stops, Attic Insulation Shields (Instruction Sheet S-2) and the general instructions for installing chimney above offset.

Locking Bands (LB) or 3 stainless steel sheet metal screws must be used to couple an elbow to another elbow/offset or to a threaded chimney section.

FIG. 7 - ELBOW INSTALLATION

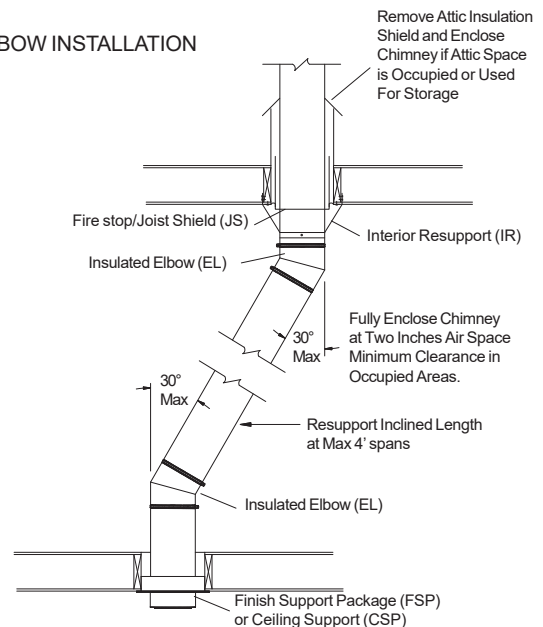

NOTE: Fig. 8 represents a single offset. A maximum of two separate offsets are permitted per system.

INTERIOR RESUPPORT ASSEMBLY (PART NO. IR, All Sizes)

The Interior Resupport Assembly (Part No. IR) is comprised of a support band with attached straps. The Interior Resupport part may be used for all sizes of chimney.

The Selkirk Chimney System (SCS) Interior Resupport Assembly allows for two different methods of chimney resupport.

The first method is used when an immediate section of chimney above the upper offset passes through a joist area. With the appropriate Fire Stop/Joist Shield (JS) in place, clamp the Interior Resupport support band around the chimney, using two 1/4" x 1/2" long carriage bolts and two 1/2" x 2" long carriage bolts and hex nuts. Attach support band to the pipe with six sheet metal screws as shown in Figure 8.

The Interior Resupport straps are then nailed to the framing joists with at least two 8 penny nails per strap. The maximum length of chimney which may be supported is 18 feet, which includes the offset lengths below, any vertical run to the resupport and the vertical run above the Interior Resupport. It does not include the length below the lower Elbow/ Offset which is supported from below (Figure 8).

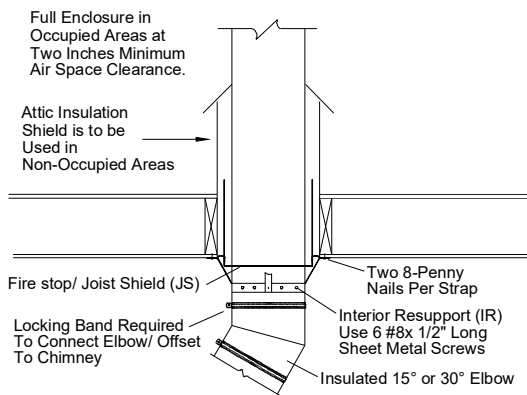
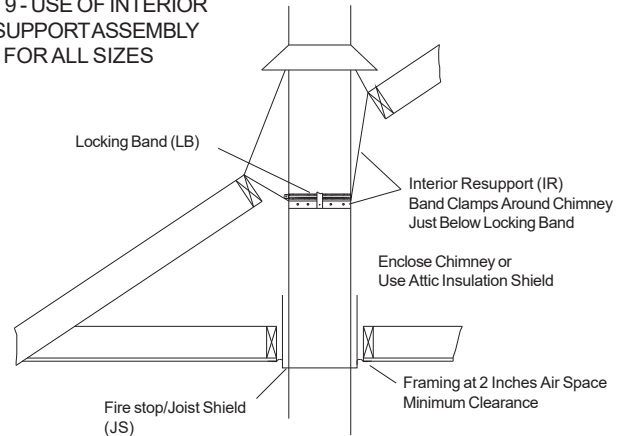

FIG 8 - INTERIOR RESUPPORT (IR) USE WHEN THE INSTALLATION OF AN INTERIOR RESUPPORT BELOW A LOCKING BAND IS NOT POSSIBLE

The second means of support is used primarily when the immediate sections of the upper offset do not pass through a joist area and resupport is necessary. The band is clamped around the chimney, using two 1/4" x 1/2" long carriage bolts and two 1/4" x 2" long carriage bolts and hex nuts. Install band immediately below a Locking Band and the straps are nailed to the framing with at least two 8 penny nails per strap (See Fig. 9). Observe the two inch air space minimum clearance between the chimney and framing. The same 18 foot limit of supportable chimney length applies to this resupport method.

FIG 9 - USE OF INTERIOR RESUPPORT ASSEMBLY (IR) FOR ALL SIZES



Full Enclosure at Minimum Two Inches Air Space Clearance in Occupied Areas.